

## Product overview

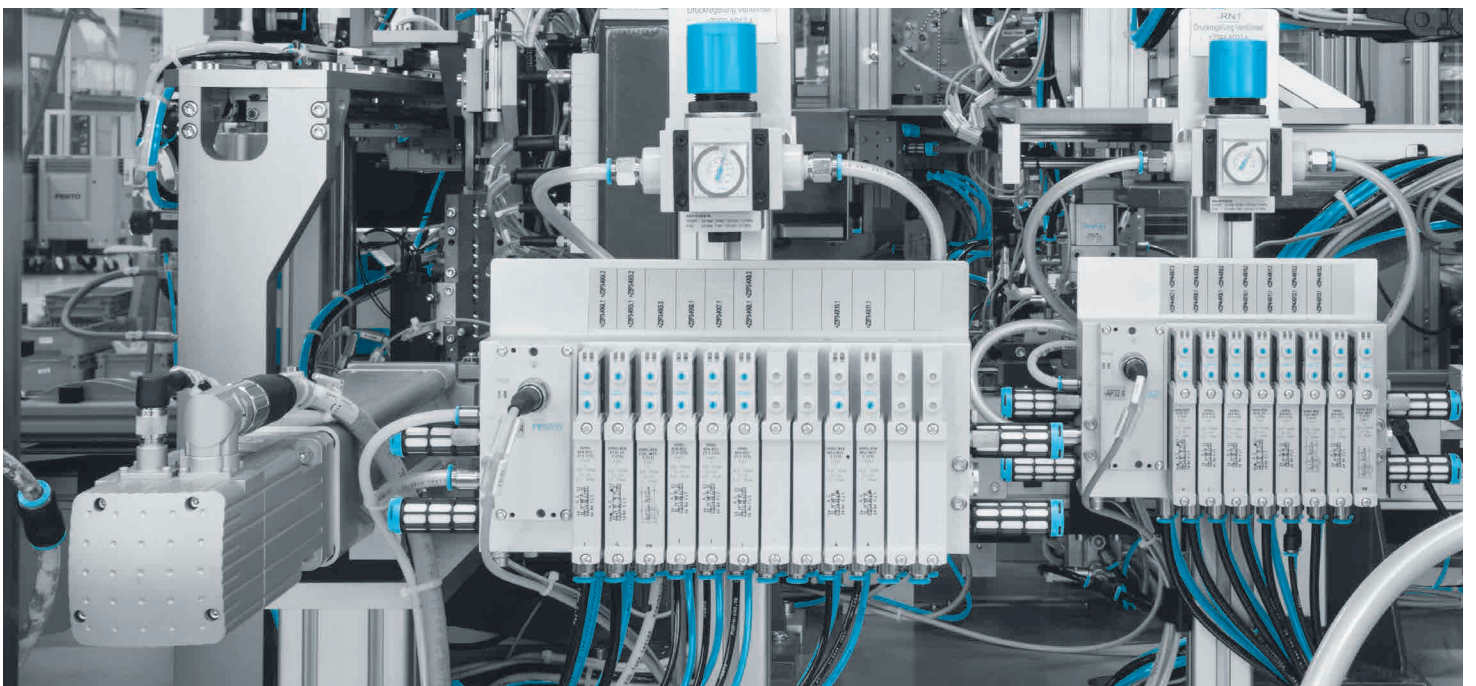

# The Festo product range – always available online or offline

## Find your perfect solution quickly –

in our Online Shop → [www.festo.com](http://www.festo.com) or in digital product catalogue on DVD

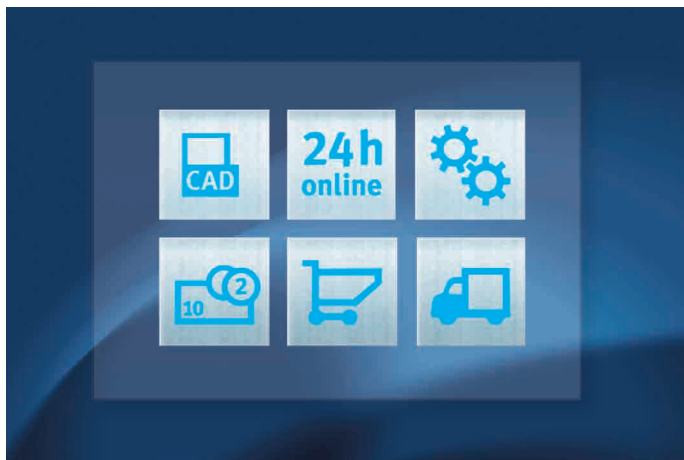

## Our Online Shop offers you advantages around the clock → [www.festo.com](http://www.festo.com)

- The online advantage: always up to date, more engineering tools, the spare parts catalogue and our Support Portal
- Select products with ease and confidence
- Price and delivery time always up to date
- Quick ordering – instant confirmation
  
- Optimum planning reliability – you have an overview of all delivery dates and orders. Includes order tracking and delivery status display, even for orders not made via the Online Shop.
- Fast data exchange – share baskets with colleagues/customers/suppliers with access to the Online Shop.
- Error-free procurement – give your purchaser parts lists as a CSV file.
  
- Easy editing – conveniently download order confirmations, delivery notes and invoices.
- Easy reordering – reorder previous orders with just a few clicks.
- Greater organisation and transparency – create stock labels using our free Label Designer. Includes a product picture and further details such as optimum ordering quantity for stock goods.

You can find details about our Online Shop here → [www.festo.com/ols](http://www.festo.com/ols)

## Or select products offline quickly and with confidence – using the Festo product catalogue on DVD

### System requirements

#### Minimum configuration

- Intel Pentium IV, 2.4 GHz+ or AMD 2400 xp+
- 1 GB RAM
- DVD-ROM drive
- Screen resolution set to 1024 x 768 pixels
- Operating system: Microsoft Windows Vista SP2
- Browser: Microsoft Internet Explorer 9

#### Recommended configuration

- PC, no more than 4 years old
- Laptop, no more than 2 years old
- Dual-core CPU with 2 GHz
- 2 GB RAM
- DVD-ROM drive
- Screen resolution set to 1280 x 1024 pixels
- Operating system: Microsoft Windows Vista or Windows 7, 8 or 10 (32 or 64 bit) incl. all Windows updates
- Browser: Microsoft Internet Explorer 11

### Installation instructions

1. Insert the DVD-ROM into the drive. If the setup program starts automatically, continue with Step 5. If not:
2. Select the **Run** command from the Start menu.
3. Enter the drive letter of your DVD-ROM drive followed by **setup.exe**. For example: **d:\setup.exe**
4. Then click **OK** or **Enter**.
5. Follow the instructions.

For further information (installation in a network, FAQs), please read **Info\_de.pdf** on the DVD or write to us: [dki@festo.com](mailto:dki@festo.com)

## Exclusion of liability

Festo provides this software to support you in the selection and ordering of Festo products. The data/results generated using the software are exclusively intended to describe the products and do not constitute warranted properties in any legal sense. Festo accepts no liability for damages caused through the use of this software, in particular in relation to consequential damage, whether personal injury, material damage or financial loss, directly related to the use of this DVD-ROM.



Editorial  
Online or offline

3 Online Shop  
13 Festo Didactic

16  
18



Pneumatic drives

19

1



Servo-pneumatic positioning systems

45

2



Electromechanical drives

49

3



Motors and controllers

54

4



Grippers

60

5



Handling systems

66

6



Vacuum technology

69

7



Valves

73

8



Valve terminals

101

9



Sensors

106

10



Vision systems

121

11



Compressed air preparation

123

12



Pneumatic connection technology

141

13



Electrical connection technology

152

14



Control technology and software

164

15



Other pneumatic devices

170

16



Process automation

173

17



Ready-to-install solutions

181

18



Function-specific systems

185

19



Services

186

20



Sales and service network – International  
What must be taken into account when using Festo products?

189  
191







Dr Ansgar Kriwet,  
Member of the Management Board, Sales

## Dear customers,

Fast, flexible and productive – these are the keywords which characterise production today. They determine success or failure amidst increasingly intense global competition.

As your partner, Festo provides you with competent support so that you can achieve maximum productivity. For example with the new core product range with more than 2200 components which cover up to 80% of all automation tasks. These products are ready for dispatch in just 24 hours, are attractively priced, in the usual Festo quality and available worldwide, even in large quantities.

New for the core product range are the additions to the individual valve series, VUVG-...-S and VUVS-...-S, offering Festo quality at an attractive price and worldwide availability. Just look for the ★ star!

We are also preparing the future for you: quite a few of the components in this catalogue, for example the automation platform CPX, have an OPC UA interface. This puts you in the ideal position if you want to invest in Industry 4.0.

Whether you are looking for a technically sophisticated system solution or a very economical alternative for components, we are here to support you achieve your goal.

With Festo, you can rely on the four principles of security, simplicity, efficiency, competency. Our experts will do everything to help you take that step to maximum productivity.

Why not take advantage of this?

Best regards,

A handwritten signature in black ink, appearing to read 'Ansgar Kriwet'. The signature is stylized and fluid, with a prominent 'A' and 'K'.

Dr Ansgar Kriwet



**We drive automation for your success.  
We are the partner to inspire you.  
We shape the future together.**

## **→ WE ARE THE ENGINEERS OF PRODUCTIVITY.**

**Festo: a partner in dialogue, a partner for maximum productivity.**

More than ever before, success in our networked world depends on having the right partners. Experts who make a valuable contribution to the achievement of your goals, who know your processes, quickly understand and resolve your challenges – and make you more productive.

Take advantage of our expertise –  
your engineers of productivity.

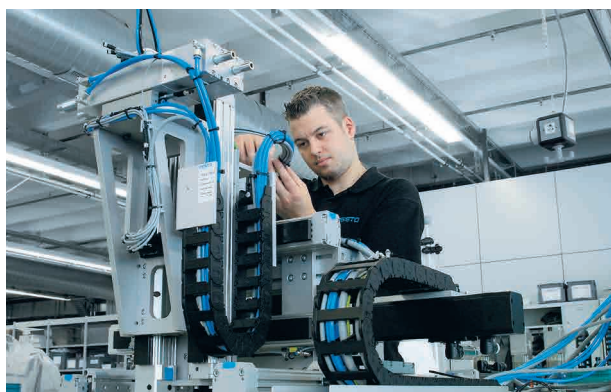

## Solutions for factory and process automation

The right solution for every requirement: Festo provides products, systems and services for electric and pneumatic control and drive technology.



## Partner for technical training and development

Everything from a single source: from equipment for technical institutes to training and consultation for manufacturing companies.



# Stars of automation: the new core product range from Festo







★ Marked with a star! Over 2200 products from our core product range are ready for dispatch from the Festo factory in 24 hours, even in large quantities. They span the entire electrical and pneumatic control sequence, from drives to accessories, for factory automation as well as for process automation.

They cover up to 80% of all automation tasks – at attractive prices and in the familiar Festo quality. Available from 13 service centres around the world!





# Greater productivity worldwide! Future-proof plants for the highest demands.

How can we make you even more productive? We are constantly asking ourselves this question. In addition to having 13 service centres around the world, we have also made our own production future-proof – to minimise the distance between our clients and us. That is precisely the goal of our plants in Scharnhausen, Germany, Mason in Ohio, USA, and Jinan in China.

## **The same standards worldwide**

All Festo plants continuously exchange information and learn from each other. This so-called Festo Value Production concept ensures the highest possible standards globally – for the benefit of our customers. The ongoing development of employees is also part of this concept and fits in with Festo as a learning company too.

## **Keeping Industry 4.0 constantly in mind**

The comprehensive approach that Festo takes to Industry 4.0 and the Internet of Things (IoT) sets it apart. Customised products demand completely networked plants, intelligent automation components and the development of intuitive interfaces between people and machines. However, these are not the only factors. The role played by people in planning and production, and ensuring they have the right training and competencies are just as important. Furthermore, engineering processes will need to be implemented faster and more intuitively in the future.

## **Anticipating future trends**

An ability to adapt, maximum added value, the best possible quality, speed, delivery reliability and short routes to the customer are the key ingredients for creating production environments that are fit for the future.



At the heart of Europe: the Scharnhausen Technology Plant in Germany. Its main goal is fast, flexible and reliable production through a smooth workflow. For both highly automated volume production and for complex, customised products.



A central position in the Midwest: Mason in Ohio, USA. 70% of customers are located within a radius of 1,000 kilometres.

#### Meeting customer needs

One of the biggest trends in production today is enhancing flexibility so that every new plant can be quickly adapted to the latest requirements. Flexible production is needed to manage changing orders, fluctuating batch sizes, large numbers of product variants, or the integration of new products. A smooth workflow that avoids bottlenecks in the value stream keeps production processes highly efficient and very reliable. Additionally, the majority of customers benefit from our plants' proximity to their own production sites – ensuring delivery is fast and direct.



In the region for the region: Jinan, China. The advantages for the Asian automation market are fast response times, outstanding flexibility and proximity to customers.



Manufacturing of the future ...  
... next steps!

FESTO



## Factory automation – for optimal productivity



In everyday factory operations, typical tasks such as gripping, moving and positioning part components, modules or complete products, are carried out by Festo automation technology.

### Fully integrated competitive edge

Our components and systems are used in production and assembly in a wide range of industry sectors, including the automotive, semiconductor and electronics industries.

The corresponding service and appropriate training make us the No. 1 partner for our customers across their entire value chain.

## Process automation – for safety during operation



Included in the industry segments for process automation are the water and wastewater technology sector, biotech and pharmaceuticals, chemical industry, laboratory automation, mining, as well as the food and beverage industry. We also offer solutions for handling fluids, gases or solids in your day-to-day processes.

### Tailored industry solutions

We offer these industries centralised and decentralised automation concepts for the production, transport, handling and disposal of fluid media.

With the support of an experienced team of experts, Festo is a competent partner for the automation of individual process steps or complete systems.

## Electric automation – optimised productivity in factory and process automation

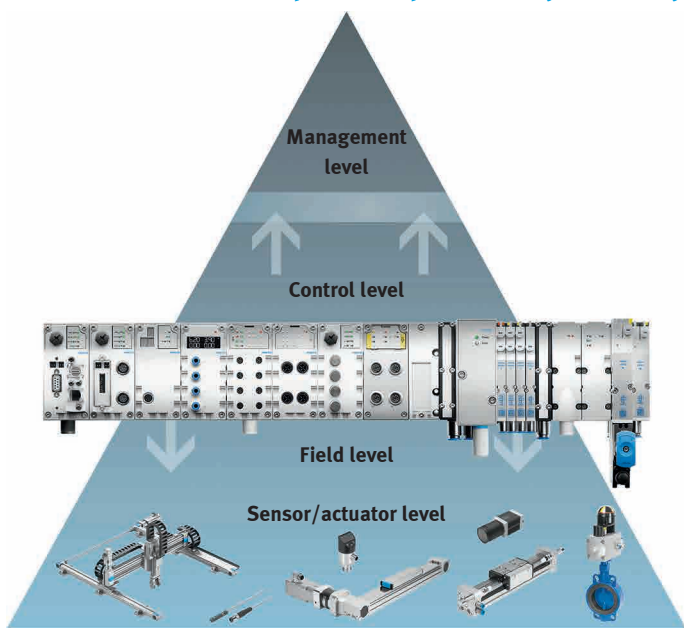

### An automation platform for factory and process automation

Our CODESYS controllers, primarily the control platform CPX with protection to IP65, create unique advantages thanks to function integration and establish new standards in factory and process automation. This includes a cost-effective overall concept, technical synergies and the advantages of decentralised installation as well as connection to Industry 4.0 thanks to OPC UA.

### Competency in intelligent automation

Used by Festo: electric drive technology in core and auxiliary machine processes – from linear motion up to motion control of decentralised modules, from the simplest web-parameterised single axis up to the Multi-Carrier-System.

### Mechatronic complete solutions

Mechatronic Motion Solutions provides you with a worldwide unique system comprising components, modules, systems and software from Festo. It integrates all types of pneumatic, servo-pneumatic and (electro)mechanical automation components and combines them according to your task. Irrespective of the control environment you use, Mechatronic Motion Solutions always provides the appropriate interfaces.



### It couldn't be easier:

1. Select the product group you require from the Table of contents  
→ 1.  
For example: Electromechanical drives 49
2. Find the products you want on the product pages using the technical features and descriptions.
3. The blue arrow directs you to the search term with which you can find all product information and process your order on the Internet. Simply add the search term or type to the Internet address. Example with search term:  
→ [www.festo.com/catalogue/spindelachse](http://www.festo.com/catalogue/spindelachse)  
Example with type:  
→ [www.festo.com/catalogue/egc-bs](http://www.festo.com/catalogue/egc-bs)

Are you already in the electronic product catalogue?  
Enter the search term in the search field next to the magnifying glass.

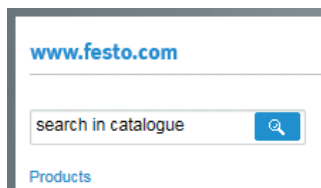

You can also search offline. The electronic product catalogue can be found on the enclosed DVD. Follow the installation instructions which you will find on the inside cover of this catalogue.

The electronic product catalogue offers additional productivity-boosting applications. See page 13 for more information.

Should you require individually tailored advice, you can find contact details on pages 189 and 190.

## ★ Quick ordering of selected basic designs

We make it easy for you!

We have compiled a globally standardised core product range that not only offers you faster and easier selection, but also fast delivery.

It has been selected by Festo experts based on actual customer requirements and covers the main applications of automation technology, while offering the best possible value for money.

### Products with a star: easy selection and fast delivery guaranteed

You can recognise these outstanding products at a glance: they are marked in the catalogues with a star.

### High level of availability

In stock and ready for immediate dispatch: these products are available in no time at all.

### More variety or individually configured? No problem!

If your requirements go beyond the main applications of automation technology or you need individually configurable products such as valve terminals, you can choose from the full spectrum of Festo's automation portfolio with all of its technological diversity. You can find these products in our electronic catalogue or online on our website and in the Online Shop.



You can benefit from these advantages whenever you need core pneumatic and electrical functions. Wherever you see this symbol in our printed or electronic catalogue, it identifies a selected product which is perfect for the main applications of automation technology. The stars will help you to find what you are looking for more quickly and place orders more easily. These star products are generally in stock and ready for immediate delivery.

### At a glance:

- Fast: ready for dispatch in 24 hours
- Superb: Festo quality at an attractive price
- Easy: just a few clicks to place an order online



Online: Enter → [www.festo.com](http://www.festo.com) in your web browser › Choose your country ... › Go. On the Homepage, select the “Products” menu.

Offline: Insert the DVD and install the product catalogue. On the start page, click on the “Products” link.

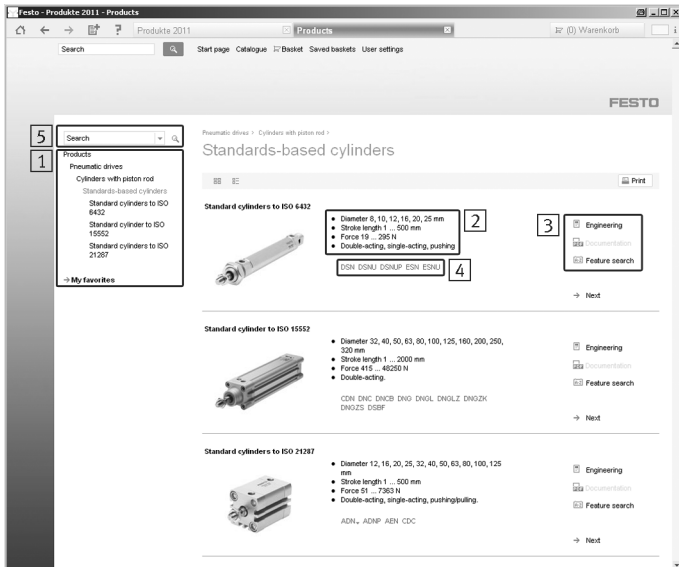

**From the product group to the product**

There are three options available:

1. Click on a product group [1] or product photo. A selection of products will then be displayed along with a list [2] of the technical features and the selectable links [3]:
  - “Engineering” starts the selection and calculation software
  - “Documentation” provides detailed information in PDF format
  - “Feature search” lets you further narrow down the product selection
2. Full text search: Enter your search term in the search field [5]. This can be made up of complete or partial keywords, part numbers, type codes or names of favourites. Depending on your input, a selection of products as described in step [1] will be displayed or you will be taken directly to the product you searched for.
3. Quick link: Use the quick link [4] to take you directly to the required product by clicking on an order code.

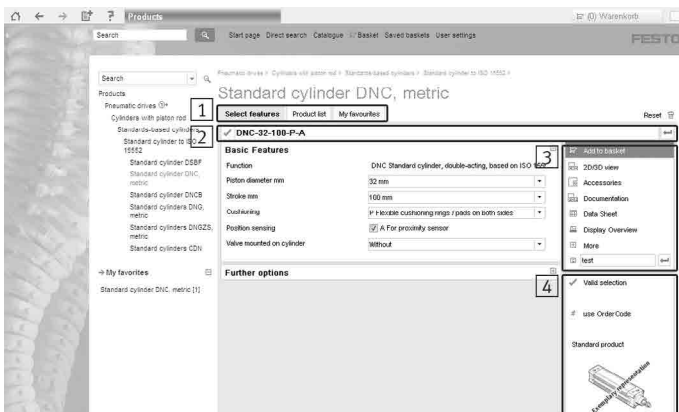

**Functions in the product configurator**

1. Tab navigation [1]
  - “Select features”: Select the appropriate features here
  - “Product list”: Lists all products in the product group
2. Input field for order code [2]: Enter the exact order code here.
3. Other actions [3] which are available following a correct configuration:
  - “Add to basket”: Adds your product to the basket, see also section “Exporting your basket” and “Managing your basket”
  - “2D/3D view”: Creates a CAD model, see the section “Viewing CAD models”
  - “Accessories”: Lists suitable accessories
  - “Technical data”: Contains all the relevant technical data
  - “Display Overview”: Displays an overview of all selected models
4. Details [4]: Here you will find information such as part number, price, product graphic, product illustration and circuit symbol.

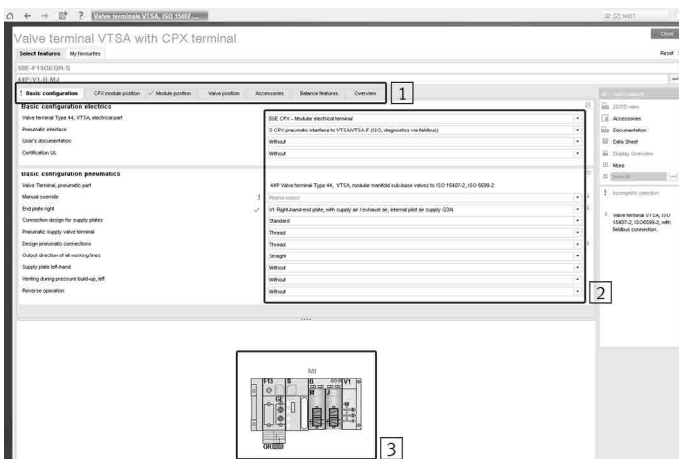

**Selecting product features in the product configurator**

1. Select the product features:
  - Navigate using the tabs [1].
  - Configure your product by selecting the required features [2] on the tabs [1] running from left to right.
  - The tabs [1] give you a quick overview of all the selected features. Missing features are marked with a blue exclamation mark and incorrect features are marked in red. Clicking on the feature takes you directly to it, so that you can then change it.
2. Graphical representation [3]: A dynamic graphic<sup>1)</sup> is created based on your current configuration.
3. Add the product to your basket: Once the configuration is complete, you can add products to the basket by clicking on “Add to basket”. A message is displayed to confirm that the product has been added successfully. To find out how to place an order, see section “Managing your basket”.

1) Available for the valve terminal and service unit product groups.

Online: Enter → [www.festo.com](http://www.festo.com) in your web browser › Choose your country ... › Go. On the Homepage, select the “Products” menu.

Offline: Insert the DVD and install the product catalogue. On the start page, click on the “Products” link.

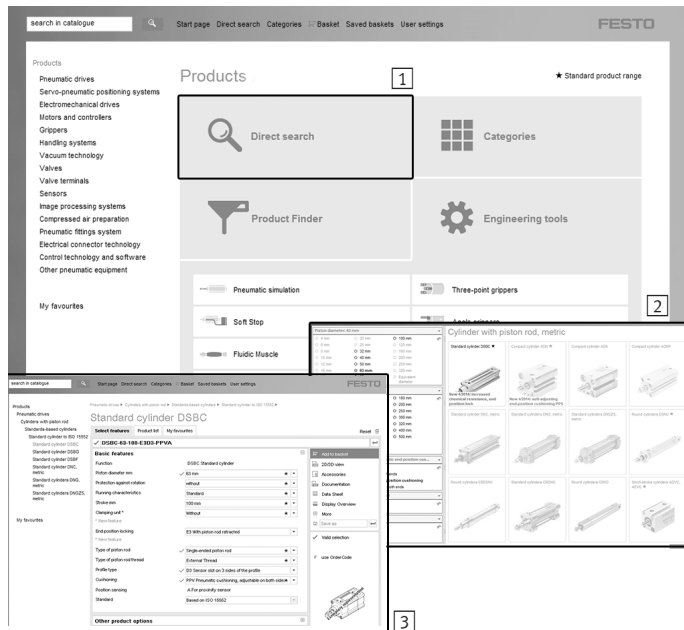

### Selecting product features in the product finder

1. Click on the blue button “Product finder” [1] and select the required product group.
2. Select the required technical features in the selection field [2] on the left-hand side.
3. Then click on a product photo. The configurator [3] opens with the features you selected.

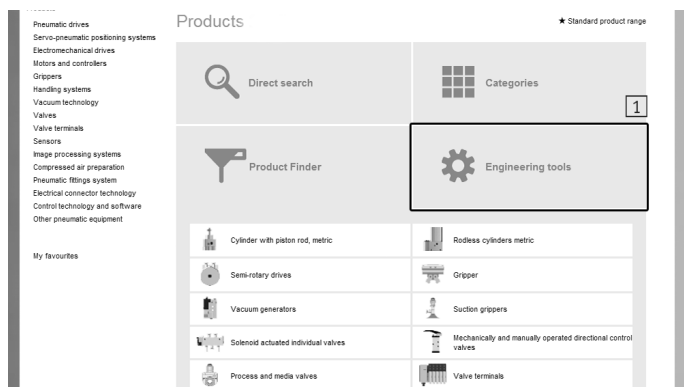

### Engineering tools for appropriate products for your applications

1. Click on the blue button “Engineering” [1] and select the required engineering tool.

This tool guides you step-by-step to the application simulation based on the technical features you selected and suggests the appropriate products for your application.

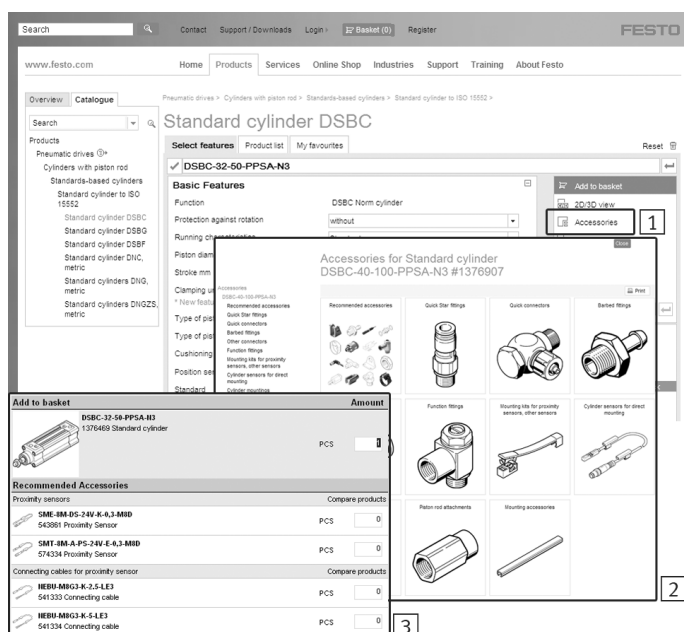

### Finding the appropriate accessories quickly

1. Select the required features in the configurator.
  2. Click on the “Accessories” button [1] on the right-hand side.
  3. Select the required accessory from the accessories on offer [2].
- The tool will take you to the appropriate accessory selection list.

Tip:

For some cylinder series you can find the appropriate accessories faster by selecting “Recommended accessories” from the accessories on offer [2]. For some cylinder series you will also find “Recommended accessories” [3] after you have added your selection to the basket.





Online: Please register as a user to use the functions described on this page.

Offline: Registration is not required to use the functions on this page.

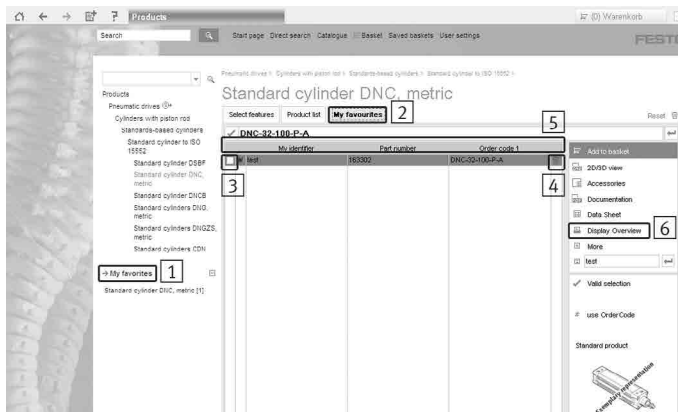

**My favourites**

You can save as many product configurations as favourites as you want. To display the list of all stored favourites [1]:

- Click on the “My favourites” tab [2]. A table containing your saved favourites is displayed. This shows the name of the favourite, part number, type code and a button [4] for deleting the favourite.
- Double-clicking on a row in the configuration opens the corresponding configuration window [3].
- You can sort your favourites by clicking on the column headings [5].
- You can select multiple favourites and compare them by clicking on “Product compare” in the field on the right [6].

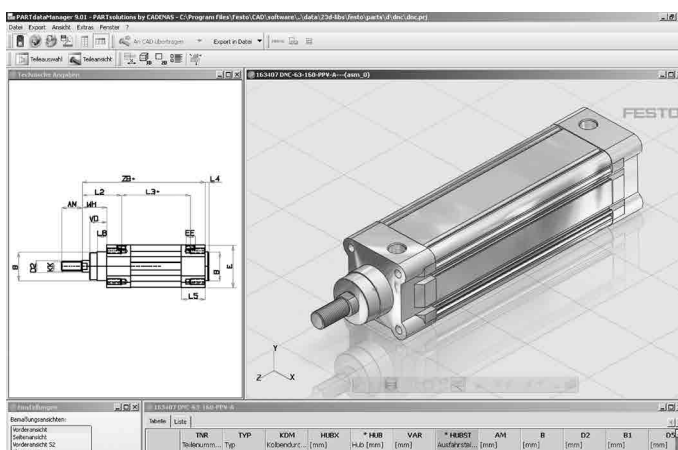

**Viewing CAD models**

Clicking on the “2D/3D view” icon opens a window containing a CAD preview of the product. The “Export” function lets you export the files to your CAD system in the right format.

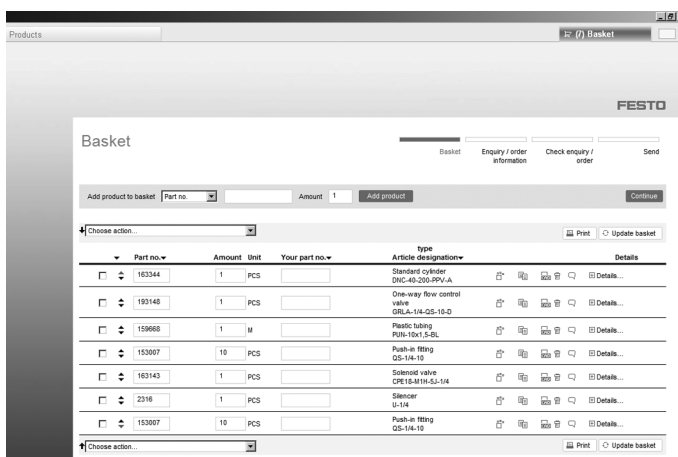

**Exporting your basket ...**

1. ... as a csv file: To do this, click on “Export” [1], choose “Save as” in the new window and specify where you want to save it to. This file can then be opened in Excel, for example, and edited.
2. ... in your choice of format: To do this, click “Settings” [3] and specify which information is to be exported.

**Managing your basket**

1. Upload the basket directly to the Online Shop and place your order: To upload a basket directly to the Online Shop, simply click on “Export to online basket” [2]. An Internet connection is established and the products are transferred to the online basket. After logging in via “Login”, your net prices and delivery times are displayed. Now just place your order and you’re done!
2. Place order: To place an order, simply print out your basket and send it to Festo by fax or export it as an e-mail.

Online: **The Support Portal**  
 All product information can be accessed centrally → [www.festo.com/sp](http://www.festo.com/sp)



### Round-the-clock benefits

- **One-step ordering process** – no waiting times between request, pricing information and order.
- **Complete overview of all orders** – order tracking with search function, status display in lists and easy reordering.
- Share baskets – make your basket available to colleagues with access to the Online Shop.
- **Download all documents for a complete basket** – complete documentation for the selected products.
- **Continuous availability** – product information, documentation, prices, availability, ordering, etc.
- **Reliable and secure procurement processes** – import parts lists as a CSV file or by copying and pasting. Export to Office applications.

### Always in control

When you register you have access to all the latest information on all the products and their availability at all times

You will find the Online Shop at [www.festo.com](http://www.festo.com)

Already registered?

Then you can log in directly via [www.festo.com/login](http://www.festo.com/login) or by clicking on “Login”.

If you have not yet registered, open the registration form by clicking on “Register”.

Further information on the Festo Online Shop

[www.festo.com/ols](http://www.festo.com/ols)



## Festo – partner for automation

### Integrated information ...

... is a prerequisite for successful pneumatic and electric automation. That's why Festo sees itself as a partner to its customers and maintains a continuous dialogue with them to provide and exchange expert and comprehensive information.

### Directly

- Worldwide consultation provided by more than 1,000 sales engineers and project engineers with up-to-date product and industry knowledge
- Hotlines to answer all your questions
- Experts on components, modules, systems and industries

### At events

- Over 120 trade fairs around the world each year
- Expotainer – the exhibition that comes to you
- Technology days – specialised presentations and exhibits concerning current topics in the field of automation
- Automation lectures – a series of specialised presentations based on actual practice for real applications

### In printed form

- trends in automation – the customer magazine with application examples, news and innovations from the world of automation technology

### Documentation

- The printed Festo catalogue. Automation in a compact volume and with a clear structure
- Industry catalogues
- Manuals and operating instructions
- System descriptions and product overview posters
- Specialist literature

Everything can be found on our Support Portal at → [www.festo.com/sp](http://www.festo.com/sp)

Are you familiar with our basic and further training courses? Festo Didactic brings together and promotes the transfer of expertise: Festo Didactic → 18.  
After all, productivity begins with training.



### Electronically

- Always up-to-date: → [www.festo.com](http://www.festo.com)
- On the Internet or as a DVD-ROM: database-supported catalogue in 26 languages
- Spare parts catalogue
- Online Shop
- Engineering tools for easier and faster design and energy-efficient solutions

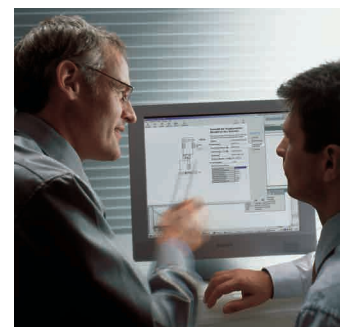



Festo Didactic is the world's leading supplier to technical educational institutions and provider of consulting and training services to industry. The product and service portfolio offers customers an integrated approach, covering all technological areas of factory and process automation. As an innovation leader and one of the world's largest suppliers of automation technology, Festo sets benchmarks.

This can be seen in the range of training courses on automation technology offered by Festo Didactic: pneumatics or hydraulics, PLC technology or networking of decentralised components as well as open- and closed-loop control of systems. Customers therefore benefit twice, since the close cooperation with Festo AG & Co. KG provides access to the latest devices and systems. The content is delivered by experienced trainers and is tailored to each individual group of participants.



**Selection of current training courses**

**AUT 511: Industry 4.0 – Interaction of components and technologies**

Industry 4.0 utilises a number of different technologies and integrates these to form a complete system. This is characterised by the intelligence of the individual components and the fact that they can be networked to form a smart factory. This course uses the CP Lab and CP Factory to demonstrate how components within a complete production process can interact. At the same time, participants develop possible applications for integrating Industry 4.0 into their lesson.

**Industry 4.0: Enabling the production of tomorrow**

The goal of Industry 4.0 is the smart factory. This is mainly characterised by its ability to produce customised products at the same cost as mass-produced ones. This demands very stable processes and a high level of adaptability. This cannot be achieved by technical solutions alone. Instead, it requires smart interactions between the ever expanding possibilities offered by technology, organisational structures that provide the necessary leeway and the knowledge and skills of employees.

The key to shaping these interactions is for individuals and the organisation to have the competencies that enable them to apply the principles of self-organisation in open and unpredictable, complex and dynamic situations. And from a technical, procedural and social point of view. Against this background, individual competencies that were of little relevance before are gaining in importance as part of Industry 4.0. These include the ability to reflect and anticipate, as well as the ability to recognise patterns, to communicate at a complex level and to create new ideas.

All our services are focused on developing technical, social and procedural competencies. We always combine the transfer of knowledge with the development of skills and the practical transfer to the participants' working environment, whether in public courses, company-specific training courses or during process-oriented consultation. This ensures that your employees can not only use Industry 4.0 technologies, but apply and develop them in a targeted way to increase efficiency and performance in your company. You will find a small selection of these courses on this page.

**AUT 521: Industry 4.0 – Applications in operational practice**

Industry 4.0 offers users of intelligent systems a range of applications which could previously either not be implemented or only through laborious manual work. This includes operating and maintaining the systems as well as planning, controlling and tracking jobs and controlling system operation. This course uses CP Lab and CP Factory to show examples of how such applications can be used within a complete production process. At the same time, participants develop initial possible applications for integrating typical Industry 4.0 tasks into their lesson.

**TCM 231: Industry 4.0 – Strategic competency management (assessment)**

Industry 4.0 has a significant influence on the work done in a company. Activities and responsibilities change, new tasks emerge, old tasks are dropped or become less important. Integrating employees in this process and preparing them properly for the demands of their new jobs requires more than training. Because it is not just knowledge that is important, but ability plays a role too. And not just the ability to do something, but also the willingness to do so. The need for a strategic approach to the competencies required in the company for Industry 4.0 solutions therefore seems inevitable.

**TCM 241: Industry 4.0 – Identifying potential and developing your own strategy**

The benefits of Industry 4.0 are well known and are being emphasised more and more often. Nevertheless, many decision makers are unsure as there seem to be too many unanswered questions. For example about the benefits for the company of using Industry 4.0 solutions and the amortisation period for the necessary investments; about whether there is an "absolute" Industry 4.0 and the extent to which Industry 4.0 solutions are needed. And about the consequences this may have. This workshop uses a fictitious case study and the VDMA Industry 4.0 toolbox to answer these and other questions.

**PT 221- Bionic thinking – Agile development inspired by nature**

Nature is adaptable, creative and efficient. That is why Festo established the Bionic Learning Network: to learn from nature's rich treasures and get new inspiration for industry. You benefit from the wealth of experience of the Bionic Learning Network and learn how to apply bionic approaches to the development of technical innovations. This one-day event teaches bionics as an interdisciplinary science. The participants learn about creative methods and apply them in practical exercises. This training course is especially interesting for industrial product and project managers, as well as developers and innovation managers.

Detailed information as well as course dates, locations and costs: → [www.festo-tac.com](http://www.festo-tac.com) – Tel. +49 (0) 800/3378682

## Software tool

## Pneumatic sizing

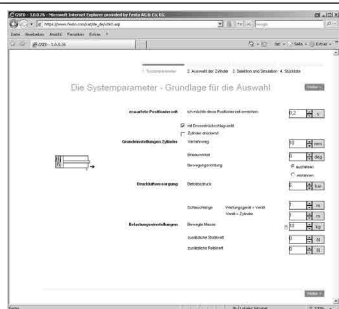

Perfect simulations replace expensive actual tests.

The tool is an expert system that supports you in the selection and configuration of the entire pneumatic control chain. If one parameter is changed, the program automatically adapts all the others.

This tool can be found

- either in the electronic catalogue by clicking on the blue button “Engineering”
- or on the DVD under Engineering Tools.

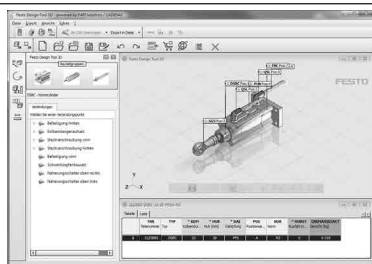
Festo Design Tool 3D  
FDT 3D

The Festo Design Tool 3D is a 3D product configurator for generating specific CAD product combinations from Festo. The configurator makes your search for the right accessory easier, more reliable and faster.





You can then order the module that has been created with a single order code – either completely pre-assembled or as individual parts in a single box. As a result, your bill of materials is considerably shortened and downstream processes such as product ordering, order picking and assembly are significantly simplified.

All ordering options are available in the following countries: AT, BE, CH, CZ, DE, DK, ES, FI, FR, GB, HU, IE, IT, NL, NO, PL, RU, SE, SI, SK.



This tool can be found

- either via the address: [www.festo.com/FDT-3D](http://www.festo.com/FDT-3D) in the above listed countries,
- or on the CD “FDT 3D” (part no. 135595 for the above listed countries)
- or on the DVD.

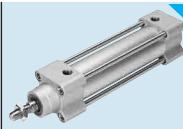

## 1 Standards-based cylinders

	 <b>Compact cylinders ADN</b>	 <b>Compact cylinders AEN</b>	 <b>Compact cylinders ADN-EL</b>	 <b>Compact cylinders, Clean Design CDC</b>
<b>Mode of operation</b>	Double-acting	Single-acting, pushing, pulling	Double-acting	Double-acting
<b>Piston diameter</b>	12 mm, 16 mm, 20 mm, 25 mm, 32 mm, 40 mm, 50 mm, 63 mm, 80 mm, 100 mm, 125 mm	12 mm, 16 mm, 20 mm, 25 mm, 32 mm, 40 mm, 50 mm, 63 mm, 80 mm, 100 mm	20 mm, 25 mm, 32 mm, 40 mm, 50 mm, 63 mm, 80 mm, 100 mm	20 mm, 25 mm, 32 mm, 40 mm, 50 mm, 63 mm, 80 mm
<b>Theoretical force at 6 bar, advancing</b>	51 ... 7363 N	54 ... 4416 N	188 ... 4712 N	141 ... 3016 N
<b>Stroke</b>	1 ... 500 mm	1 ... 25 mm	10 ... 500 mm	1 ... 500 mm
<b>Cushioning</b>	Elastic cushioning rings/pads at both ends, self-adjusting pneumatic end-position cush- ioning	Elastic cushioning rings/pads at both ends	Elastic cushioning rings/pads at both ends	Elastic cushioning rings/pads at both ends
<b>Quick ordering of selected basic designs</b>	★			
<b>Description</b>	<ul style="list-style-type: none"> <li>• ISO 21287</li> <li>• Up to 50% less installation space than comparable standards-based cylinders to ISO 15552</li> <li>• Piston rod with female or male thread</li> <li>• Wide range of variants for customised applications</li> <li>• For position sensing</li> </ul>	<ul style="list-style-type: none"> <li>• ISO 21287</li> <li>• Up to 50% less installation space than comparable standards-based cylinders to ISO 15552</li> <li>• Piston rod with female or male thread</li> <li>• Wide range of variants for customised applications</li> <li>• For position sensing</li> </ul>	<ul style="list-style-type: none"> <li>• Mounting hole pattern to ISO 21287</li> <li>• With end-position locking at both ends, front or rear</li> <li>• For position sensing</li> <li>• Piston rod with male or female thread</li> </ul>	<ul style="list-style-type: none"> <li>• ISO 21287</li> <li>• Up to 50% less installation space than comparable standards-based cylinders to ISO 15552</li> <li>• Easy-to-clean design</li> <li>• Increased corrosion protection</li> <li>• Wide range of variants for customised applications</li> <li>• Piston rod with female or male thread</li> <li>• For position sensing</li> </ul>
<b>online: →</b>	<a href="#">adn</a>	<a href="#">aen</a>	<a href="#">adn-el</a>	<a href="#">cdc</a>

Standards-based cylinders



	 <b>New</b> <b>Standards-based cylinders DSBC</b>	 <b>New</b> <b>Standards-based cylinders DSBG</b>	 <b>Standards-based cylinders DSBG</b>	 <b>Standards-based cylinder, Clean Design DSBF</b>
<b>Mode of operation</b>	Double-acting	Double-acting	Double-acting	Double-acting
<b>Piston diameter</b>	32 mm, 40 mm, 50 mm, 63 mm, 80 mm, 100 mm, 125 mm	32 mm, 40 mm, 50 mm, 63 mm, 80 mm, 100 mm, 125 mm	160 mm, 200 mm, 250 mm, 320 mm	32 mm, 40 mm, 50 mm, 63 mm, 80 mm, 100 mm, 125 mm
<b>Theoretical force at 6 bar, advancing</b>	415 ... 7363 N	415 ... 7363 N	12064 ... 48255 N	415 ... 7363 N
<b>Stroke</b>	1 ... 2800 mm	1 ... 2800 mm	1 ... 2700 mm	1 ... 2800 mm
<b>Cushioning</b>	Elastic cushioning rings/pads at both ends, self-adjusting pneumatic end-position cushioning, pneumatic cushioning adjustable at both ends	Elastic cushioning rings/pads at both ends, self-adjusting pneumatic end-position cushioning, pneumatic cushioning adjustable at both ends	Elastic cushioning rings/pads at both ends, pneumatic cushioning adjustable at both ends	Elastic cushioning rings/pads at both ends, self-adjusting pneumatic end-position cushioning, pneumatic Cushioning, adjustable at both ends
<b>New</b>	<ul style="list-style-type: none"> <li>Optimised for low friction, with clamping profile</li> </ul>	<ul style="list-style-type: none"> <li>Optimised for low friction, with tie rods</li> </ul>		
<b>Quick ordering of selected basic designs</b>	★			
<b>Description</b>	<ul style="list-style-type: none"> <li>ISO 15552 (ISO 6431, VDMA 24562)</li> <li>Self-adjusting pneumatic end-position cushioning which adapts optimally to changes in load and speed</li> <li>Wide range of variants for customised applications</li> <li>Comprehensive range of mounting accessories for just about every type of installation</li> <li>For position sensing</li> </ul>	<ul style="list-style-type: none"> <li>ISO 15552 (ISO 6431, VDMA 24562)</li> <li>Sturdy tie rod design</li> <li>Self-adjusting pneumatic end-position cushioning which adapts optimally to changes in load and speed</li> <li>Comprehensive range of mounting accessories for just about every type of installation</li> <li>For position sensing</li> </ul>	<ul style="list-style-type: none"> <li>ISO 15552 (ISO 6431, VDMA 24562)</li> <li>Sturdy tie rod design</li> <li>Pneumatic end-position cushioning, adjustable at both ends</li> <li>Optionally without end-position cushioning, adjustable at both ends, and position sensing, resulting in a price advantage</li> <li>New: optionally with spacer bolt attachment</li> <li>For position sensing</li> </ul>	<ul style="list-style-type: none"> <li>ISO 15552</li> <li>Increased corrosion protection</li> <li>Easy-to-clean design</li> <li>FDA-approved lubrication and sealing on the basic version</li> <li>Long service life thanks to optional seal for unlubricated operation</li> <li>Self-adjusting pneumatic end-position cushioning which adapts optimally to changes in load and speed</li> <li>For position sensing</li> </ul>
<b>online:</b> →	<a href="#">dsbc</a>	<a href="#">dsbg</a>	<a href="#">dsbg</a>	<a href="#">dsbf</a>

## 1 Standards-based cylinders





	 <b>Standards-based cylinders DNC</b>	 <b>Round cylinders DSNU</b>	 <b>Round cylinders ESNU</b>
<b>Mode of operation</b>	Double-acting	Double-acting	Single-acting, pushing
<b>Piston diameter</b>	32 mm, 40 mm, 50 mm, 63 mm, 80 mm, 100 mm, 125 mm	8 mm, 10 mm, 12 mm, 16 mm, 20 mm, 25 mm	8 mm, 10 mm, 12 mm, 16 mm, 20 mm, 25 mm
<b>Theoretical force at 6 bar, advancing</b>	415 ... 7363 N	23 ... 295 N	19 ... 271 N
<b>Stroke</b>	2 ... 2000 mm	1 ... 500 mm	1 ... 50 mm
<b>Cushioning</b>	Elastic cushioning rings/pads at both ends, pneumatic cushioning adjustable at both ends	Elastic cushioning rings/pads at both ends, self-adjusting pneumatic end-position cushioning, pneumatic cushioning adjustable at both ends	Elastic cushioning rings/pads at both ends
<b>Quick ordering of selected basic designs</b>		★	
<b>Description</b>	<ul style="list-style-type: none"> <li>• ISO 15552 (ISO 6431, VDMA 24562)</li> <li>• Wide range of variants for customised applications</li> <li>• Comprehensive range of mounting accessories for just about every type of installation</li> <li>• For position sensing</li> </ul>	<ul style="list-style-type: none"> <li>• ISO 6432</li> <li>• Wide range of variants for customised applications</li> <li>• Good running performance and long service life</li> <li>• Self-adjusting pneumatic end-position cushioning which adapts optimally to changes in load and speed</li> <li>• Piston rod with male or female thread</li> <li>• For position sensing</li> </ul>	<ul style="list-style-type: none"> <li>• ISO 6432</li> <li>• Wide range of variants for customised applications</li> <li>• Good running performance and long service life</li> <li>• Piston rod with female or male thread</li> <li>• For position sensing</li> </ul>
<b>online:</b> →	<a href="#">dnc</a>	<a href="#">dsnu</a>	<a href="#">esnu</a>







Round cylinders

	 <b>Round cylinders DSNU</b>	 <b>Round cylinders ESNU</b>	 <b>Round cylinders EG-PK</b>
<b>Mode of operation</b>	Double-acting	Single-acting, pushing	Single-acting, pushing
<b>Piston diameter</b>	32 mm, 40 mm, 50 mm, 63 mm	32 mm, 40 mm, 50 mm, 63 mm	4 mm, 6 mm, 2,5 mm
<b>Theoretical force at 6 bar, advancing</b>	482.5 ... 1870.3 N	406 ... 1765 N	1.9 ... 11.8 N
<b>Stroke</b>	1 ... 500 mm	1 ... 50 mm	5 ... 25 mm
<b>Cushioning</b>	Elastic cushioning rings/pads at both ends, self-adjusting pneumatic end-position cushioning, pneumatic cushioning adjustable at both ends	Elastic cushioning rings/pads at both ends	At one end, non-adjustable, no cushioning
<b>Description</b>	<ul style="list-style-type: none"> <li>• Wide range of variants for customised applications</li> <li>• Good running performance and long service life</li> <li>• Self-adjusting pneumatic end-position cushioning which adapts optimally to changes in load and speed</li> <li>• Piston rod with male or female thread</li> <li>• For position sensing</li> </ul>	<ul style="list-style-type: none"> <li>• Wide range of variants for customised applications</li> <li>• Good running performance and long service life</li> <li>• Piston rod with female or male thread</li> <li>• For position sensing</li> </ul>	<ul style="list-style-type: none"> <li>• Micro cylinder</li> <li>• Barbed fitting for plastic tubing with standard I. D.</li> <li>• Without position sensing</li> </ul>
<b>online:</b> →	<a href="#">dsnu</a>	<a href="#">esnu</a>	<a href="#">eg-pk</a>





## 1 Stainless-steel cylinders

	 <b>Round cylinders CRDSNU, CRDSNU-B</b>	 <b>Round cylinders CRDSNU, CRDSNU-B</b>	 <b>Standards-based cylinders CRDNG, CRDNGS</b>	 <b>Round cylinders CRHD</b>
<b>Mode of operation</b>	Double-acting	Double-acting	Double-acting	Double-acting
<b>Piston diameter</b>	12 mm, 16 mm, 20 mm, 25 mm	32 mm, 40 mm, 50 mm, 63 mm	32 mm, 40 mm, 50 mm, 63 mm, 80 mm, 100 mm, 125 mm	32 mm, 40 mm, 50 mm, 63 mm, 80 mm, 100 mm
<b>Theoretical force at 6 bar, advancing</b>	68 ... 295 N	483 ... 1870 N	483 ... 7363 N	483 ... 4712 N
<b>Stroke</b>	1 ... 500 mm	1 ... 500 mm	10 ... 2000 mm	10 ... 500 mm
<b>Cushioning</b>	Elastic cushioning rings/pads at both ends, self-adjusting pneumatic end-position cushioning, pneumatic cushioning adjustable at both ends	Elastic cushioning rings/pads at both ends, self-adjusting pneumatic end-position cushioning, pneumatic cushioning adjustable at both ends	Pneumatic Cushioning adjustable at both ends	Pneumatic Cushioning adjustable at both ends
<b>Description</b>	<ul style="list-style-type: none"> <li>• ISO 6432</li> <li>• Corrosion-resistant against aggressive ambient conditions</li> <li>• Easy-to-clean design</li> <li>• Long service life thanks to optional dry-running seal</li> <li>• Wide range of variants for customised applications</li> <li>• Self-adjusting pneumatic end-position cushioning which adapts optimally to changes in load and speed</li> <li>• For position sensing</li> </ul>	<ul style="list-style-type: none"> <li>• Corrosion-resistant against aggressive ambient conditions</li> <li>• Easy-to-clean design</li> <li>• Long service life thanks to optional dry-running seal</li> <li>• Wide range of variants for customised applications</li> <li>• Self-adjusting pneumatic end-position cushioning which adapts optimally to changes in load and speed</li> <li>• For position sensing</li> </ul>	<ul style="list-style-type: none"> <li>• ISO 15552 (ISO 6431, VDMA 24562)</li> <li>• Corrosion-resistant against aggressive ambient conditions</li> <li>• Easy-to-clean design</li> <li>• Variants: through piston rod, heat-resistant design</li> <li>• Threaded mounting, mounting via accessories</li> <li>• For position sensing</li> </ul>	<ul style="list-style-type: none"> <li>• Corrosion-resistant against aggressive ambient conditions</li> <li>• Easy-to-clean design, optimised for very exacting demands</li> <li>• Flexible design thanks to different end caps</li> <li>• Piston rod with male thread</li> <li>• For position sensing</li> </ul>
<b>online:</b> →	<a href="#">crdnsu</a>	<a href="#">crdsnu</a>	<a href="#">crdng</a>	<a href="#">crhd</a>



Compact, short-stroke and flat cylinders

	 <b>Compact cylinders ADN</b>	 <b>Compact cylinders AEN</b>	 <b>Compact cylinders ADNGF</b>	 <b>Compact cylinders ADN-EL</b>
<b>Mode of operation</b>	Double-acting	Single-acting, pushing, pulling	Double-acting	Double-acting
<b>Piston diameter</b>	12 mm, 16 mm, 20 mm, 25 mm, 32 mm, 40 mm, 50 mm, 63 mm, 80 mm, 100 mm, 125 mm	12 mm, 16 mm, 20 mm, 25 mm, 32 mm, 40 mm, 50 mm, 63 mm, 80 mm, 100 mm	12 mm, 16 mm, 20 mm, 25 mm, 32 mm, 40 mm, 50 mm, 63 mm, 80 mm, 100 mm, Führungsstange mit Joch	20 mm, 25 mm, 32 mm, 40 mm, 50 mm, 63 mm, 80 mm, 100 mm
<b>Theoretical force at 6 bar, advancing</b>	51 ... 7363 N	54 ... 4416 N	68 ... 4712 N	188 ... 4712 N
<b>Stroke</b>	1 ... 500 mm	1 ... 25 mm	1 ... 400 mm	10 ... 500 mm
<b>Cushioning</b>	Elastic cushioning rings/pads at both ends, self-adjusting pneumatic end-position cushioning	Elastic cushioning rings/pads at both ends	Elastic cushioning rings/pads at both ends, self-adjusting pneumatic end-position cushioning	Elastic cushioning rings/pads at both ends
<b>Quick ordering of selected basic designs</b>	★			
<b>Description</b>	<ul style="list-style-type: none"> <li>• ISO 21287</li> <li>• Up to 50% less installation space than comparable standards-based cylinders to ISO 15552</li> <li>• Piston rod with female or male thread</li> <li>• Wide range of variants for customised applications</li> <li>• For position sensing</li> </ul>	<ul style="list-style-type: none"> <li>• ISO 21287</li> <li>• Up to 50% less installation space than comparable standards-based cylinders to ISO 15552</li> <li>• Piston rod with female or male thread</li> <li>• Wide range of variants for customised applications</li> <li>• For position sensing</li> </ul>	<ul style="list-style-type: none"> <li>• Mounting hole pattern to ISO 21287</li> <li>• Piston rod secured against rotation by a guide rod and yoke plate</li> <li>• Plain-bearing guide</li> <li>• Optionally with through piston rod</li> <li>• For position sensing</li> </ul>	<ul style="list-style-type: none"> <li>• Mounting hole pattern to ISO 21287</li> <li>• With end-position locking at both ends, front or rear</li> <li>• For position sensing</li> <li>• Piston rod with female or male thread</li> </ul>
<b>online: →</b>	<a href="#">adn</a>	<a href="#">aen</a>	<a href="#">adngf</a>	<a href="#">adn-el</a>



## 1 Compact, short-stroke and flat cylinders

	 <b>Compact cylinders, Clean Design CDC</b>	 <b>Short-stroke cylinders ADVC, AEOVC</b>	 <b>Compact cylinders ADVU, AEUU, AEUUZ</b>	 <b>Compact cylinders ADVUL</b>
<b>Mode of operation</b>	Double-acting	Double-acting, single-acting, pushing	Double-acting, single-acting, pushing, pulling	Double-acting
<b>Piston diameter</b>	20 mm, 25 mm, 32 mm, 40 mm, 50 mm, 63 mm, 80 mm	4 mm, 6 mm, 10 mm, 12 mm, 16 mm, 20 mm, 25 mm, 32 mm, 40 mm, 50 mm, 63 mm, 80 mm, 100 mm	12 mm, 16 mm, 20 mm, 25 mm, 32 mm, 40 mm, 50 mm, 63 mm, 80 mm, 100 mm, 125 mm, Square piston rod	12 mm, 16 mm, 20 mm, 25 mm, 32 mm, 40 mm, 50 mm, 63 mm, 80 mm, 100 mm, Guide rod with yoke
<b>Theoretical force at 6 bar, advancing</b>	141 ... 3016 N	4.9 ... 4712 N	42 ... 7363 N	51 ... 4712 N
<b>Stroke</b>	1 ... 500 mm	2.5 ... 25 mm	1 ... 2000 mm	1 ... 400 mm
<b>Cushioning</b>	Elastic cushioning rings/pads at both ends	Elastic cushioning rings/pads at both ends	Elastic cushioning rings/pads at both ends	Elastic cushioning rings/pads at both ends
<b>Quick ordering of selected basic designs</b>		★		
<b>Description</b>	<ul style="list-style-type: none"> <li>• ISO 21287</li> <li>• Up to 50% less installation space than comparable standards-based cylinders to ISO 15552</li> <li>• Easy-to-clean design</li> <li>• Increased corrosion protection</li> <li>• Wide range of variants for customised applications</li> <li>• Piston rod with female or male thread</li> <li>• For position sensing</li> </ul>	<ul style="list-style-type: none"> <li>• Mounting hole pattern to VDMA 24562 as of Ø 32 mm</li> <li>• Very short overall length</li> <li>• High forces in a compact size</li> <li>• Piston rod with female or male thread</li> <li>• For position sensing with proximity sensor for T-slot and for C-slot</li> </ul>	<ul style="list-style-type: none"> <li>• 50% less installation space than comparable standards-based cylinders to ISO 15552</li> <li>• Wide range of variants for customised applications</li> <li>• Piston rod with female or male thread</li> <li>• For position sensing</li> </ul>	<ul style="list-style-type: none"> <li>• Piston rod secured against rotation by a guide rod and yoke plate</li> <li>• Plain-bearing guide</li> <li>• Optionally with through piston rod</li> <li>• For position sensing</li> </ul>
<b>online: →</b>	<a href="#">cdc</a>	<a href="#">advc</a>	<a href="#">advu</a>	<a href="#">advul</a>



## Compact, short-stroke and flat cylinders

	 <b>Flat cylinders DZF</b>	 <b>Flat cylinders DZH</b>	 <b>Flat cylinders EZH</b>
<b>Mode of operation</b>	Double-acting	Double-acting	Single-acting, pushing
<b>Piston diameter</b>	Oval piston, equivalent diameter 12 mm, 18 mm, 25 mm, 32 mm, 40 mm, 50 mm, 63 mm	Oval piston, equivalent diameter 16 mm, 20 mm, 25 mm, 32 mm, 40 mm, 50 mm, 63 mm	Rectangular piston rod, equivalent diameter 3 mm, 6 mm, 12 mm, 22 mm
<b>Theoretical force at 6 bar, advancing</b>	51 ... 1870 N	104 ... 1870 N	3.8 ... 205 N
<b>Stroke</b>	1 ... 320 mm	1 ... 1000 mm	10 ... 50 mm
<b>Cushioning</b>	Elastic cushioning rings/pads at both ends	Pneumatic cushioning adjustable at both ends	No cushioning
<b>Description</b>	<ul style="list-style-type: none"> <li>Extremely flat design</li> <li>Protected against rotation thanks to special piston shape</li> <li>Ideal for block assembly</li> <li>Wide variety of mounting and attachment options</li> <li>Piston rod with male or female thread</li> <li>For position sensing</li> </ul>	<ul style="list-style-type: none"> <li>Flat design</li> <li>Protected against rotation thanks to special piston shape</li> <li>Ideal for manifold assembly</li> <li>Wide variety of mounting and attachment options</li> <li>Piston rod with male thread</li> <li>For position sensing</li> </ul>	<ul style="list-style-type: none"> <li>Extremely flat design</li> <li>Protected against rotation thanks to special piston shape</li> <li>Wide variety of mounting and attachment options</li> <li>For position sensing</li> </ul>
<b>online: →</b>	<a href="#">dzf</a>	<a href="#">dzh</a>	<a href="#">ezh</a>



## Cartridge cylinders and multimount cylinders

	 <b>Multimount cylinders DMM, EMM</b>	 <b>Cartridge cylinders EGZ</b>
<b>Mode of operation</b>	Double-acting, single-acting, pushing, pulling	Single-acting, pushing
<b>Piston diameter</b>	10 mm, 16 mm, 20 mm, 25 mm, 32 mm	6 mm, 10 mm, 16 mm
<b>Theoretical force at 6 bar, advancing</b>	30 ... 483 N	13.9 ... 109 N
<b>Stroke</b>	1 ... 50 mm	5 ... 15 mm
<b>Cushioning</b>	Elastic cushioning rings/pads at both ends	No cushioning
<b>Description</b>	<ul style="list-style-type: none"> <li>Wide variety of mounting and attachment options</li> <li>Wide selection of piston rod variants</li> <li>Piston rod with male thread</li> <li>For position sensing</li> </ul>	<ul style="list-style-type: none"> <li>Minimal fitting space</li> <li>Installation with or without mounting components</li> <li>Piston rod with male thread</li> </ul>
<b>online: →</b>	<a href="#">dmm</a>	<a href="#">egz</a>





## 1 Cylinders with clamping unit

	 <b>Standards-based cylinders with clamping cartridge DSBC-C</b>	 <b>Compact cylinders with clamping cartridge ADN-KP</b>	 <b>Round cylinders with clamping cartridge DSNU-KP</b>
<b>Mode of operation</b>	Double-acting	Double-acting	Double-acting
<b>Piston diameter</b>	32 mm, 40 mm, 50 mm, 63 mm, 80 mm, 100 mm, 125 mm	20 mm, 25 mm, 32 mm, 40 mm, 50 mm, 63 mm, 80 mm, 100 mm	8 mm, 10 mm, 12 mm, 16 mm, 20 mm, 25 mm
<b>Theoretical force at 6 bar, advancing</b>	415 ... 7363 N	188 ... 4712 N	30 ... 295 N
<b>Stroke</b>	10 ... 2800 mm	10 ... 500 mm	1 ... 500 mm
<b>Cushioning</b>	Elastic cushioning rings/pads at both ends, self-adjusting pneumatic end-position cushioning, pneumatic cushioning adjustable at both ends	Elastic cushioning rings/pads at both ends	Elastic cushioning rings/pads at both ends, self-adjusting pneumatic end-position cushioning, pneumatic cushioning adjustable at both ends
<b>Description</b>	<ul style="list-style-type: none"> <li>• Piston rod can be held in any position</li> <li>• Piston rod can be held in position for long periods even with alternating loads, fluctuating operating pressure or leaks in the system</li> <li>• Standard hole pattern</li> <li>• Piston rod with male or female thread</li> <li>• For position sensing</li> </ul>	<ul style="list-style-type: none"> <li>• Piston rod can be held in any position</li> <li>• The piston rod can be held in position for long periods even with alternating loads, fluctuating operating pressure in the system or loss of pressure</li> <li>• Mounting hole pattern to ISO 21287</li> <li>• Piston rod with female or male thread</li> <li>• For position sensing</li> </ul>	<ul style="list-style-type: none"> <li>• Piston rod can be held in any position</li> <li>• The piston rod can be held in position for long periods even with alternating loads, fluctuating operating pressure in the system or loss of pressure</li> <li>• Mounting hole pattern to ISO 6432</li> <li>• For position sensing</li> </ul>
<b>online:</b> →	<a href="#">dsbc-c</a>	<a href="#">adn-kp</a>	<a href="#">dsnu-kp</a>



## Cylinders with clamping unit

	 <b>Round cylinders with clamping cartridge DSNU-KP</b>	 <b>Standards-based cylinders with clamping cartridge DNC-KP</b>	 <b>Cylinders with clamping unit DNCKE</b>
<b>Mode of operation</b>	Double-acting	Double-acting	Double-acting
<b>Piston diameter</b>	32 mm, 40 mm, 50 mm, 63 mm	32 mm, 40 mm, 50 mm, 63 mm, 80 mm, 100 mm, 125 mm	40 mm, 63 mm, 100 mm
<b>Theoretical force at 6 bar, advancing</b>	483 ... 1870 N	415 ... 7363 N	754 ... 4712 N
<b>Stroke</b>	1 ... 500 mm	10 ... 2000 mm	10 ... 2000 mm
<b>Cushioning</b>	Elastic cushioning rings/pads at both ends, self-adjusting pneumatic end-position cushioning, pneumatic cushioning adjustable at both ends	Elastic cushioning rings/pads at both ends, pneumatic cushioning adjustable at both ends	Pneumatic cushioning adjustable at both ends
<b>Description</b>	<ul style="list-style-type: none"> <li>• Piston rod can be clamped in any position</li> <li>• The piston rod can be held in position for long periods even with alternating loads, fluctuating operating pressure in the system or loss of pressure</li> <li>• For position sensing</li> </ul>	<ul style="list-style-type: none"> <li>• Mounting hole pattern to ISO 15552</li> <li>• The piston rod can be clamped in any position</li> <li>• The piston rod can be held in position for long periods even with alternating loads, fluctuating operating pressure in the system or loss of pressure</li> <li>• Piston rod with male or female thread</li> <li>• For position sensing</li> </ul>	<ul style="list-style-type: none"> <li>• Piston rod can be held and braked in any position</li> <li>• Variant DNCKE-...-S approved for use in safety-oriented parts of control systems</li> <li>• Mounting hole pattern to ISO 15552</li> <li>• Piston rod with male thread</li> <li>• For position sensing</li> </ul>
<b>online:</b> →	<a href="#">dsnu-kp</a>	<a href="#">dnc-kp</a>	<a href="#">dncke</a>

Rodless cylinders

	 <b>Linear drives DGC-K</b>	 <b>Linear drives DGC-G, DGC-GF, DGC-KF</b>	 <b>Linear drives with heavy-duty guide DGC-HD</b>	 <b>Linear drives SLG</b>
<b>Piston diameter</b>	18 mm, 25 mm, 32 mm, 40 mm, 50 mm, 63 mm, 80 mm	8 mm, 12 mm, 18 mm, 25 mm, 32 mm, 40 mm, 50 mm, 63 mm	18 mm, 25 mm, 40 mm	8 mm, 12 mm, 18 mm
<b>Theoretical force at 6 bar, advancing</b>	153 ... 3016 N	30 ... 1870 N	153 ... 754 N	30 ... 153 N
<b>Stroke</b>	1 ... 8500 mm	1 ... 8500 mm	1 ... 5000 mm	100 ... 900 mm
<b>Cushioning</b>	Pneumatic cushioning adjustable at both ends	Elastic cushioning rings/pads at both ends, pneumatic cushioning, adjustable at both ends, shock absorber, hard characteristic curve, shock absorber, soft characteristic curve	Shock absorber, hard characteristic curve, shock absorber, soft characteristic curve	Elastic cushioning rings/pads at both ends, shock absorber, hard characteristic curve
<b>Position sensing</b>	Via proximity sensor	Via proximity sensor	Via proximity sensor	Via proximity sensor
<b>Description</b>	<ul style="list-style-type: none"> <li>• Compact design: 30% smaller than the basic design DGC-G</li> <li>• Basic drive without guide, for simple drive functions</li> <li>• Low moving dead weight</li> <li>• Symmetrical design</li> <li>• Fully interchangeable with linear drive DGP</li> </ul>	<ul style="list-style-type: none"> <li>• Basic design, plain or recirculating ball bearing guide</li> <li>• All settings accessible from one side</li> <li>• Optionally with variable end stops and intermediate position module</li> <li>• Exchangeable with DGPL thanks to foot mountings</li> <li>• Software tool available for bearing calculation</li> <li>• Optional: NSF-H1 lubricant for the food industry (See supplementary information on materials at <a href="http://www.festo.com/sp">www.festo.com/sp</a> &gt; Certificates)</li> <li>• Optional: clamping unit for holding loads</li> </ul>	<ul style="list-style-type: none"> <li>• For maximum loads and torques thanks to duo rail guide</li> <li>• Very good operating performance under torque load</li> <li>• Long service life</li> <li>• Ideal as a basic axis for linear gantries and cantilever axes</li> <li>• Wide range of options for mounting on drive units</li> </ul>	<ul style="list-style-type: none"> <li>• Extremely flat design</li> <li>• Highest precision thanks to integrated recirculating ball bearing guide</li> <li>• Adjustable end stops</li> <li>• Wide range of supply ports</li> <li>• Available with intermediate position module</li> </ul>
<b>online:</b> →	<a href="#">dgc-k</a>	<a href="#">dgc</a>	<a href="#">dgc-hd</a>	<a href="#">slg</a>

## 1 Rodless cylinders

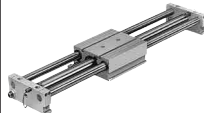
	 <b>Linear drives</b> <b>DGPL</b>	 <b>Linear drives</b> <b>DGO</b>	 <b>Linear units</b> <b>SLM</b>
<b>Piston diameter</b>	18 mm, 25 mm, 32 mm, 40 mm, 50 mm, 63 mm, 80 mm	12 mm, 16 mm, 20 mm, 25 mm, 32 mm, 40 mm	12 mm, 16 mm, 20 mm, 25 mm, 32 mm, 40 mm
<b>Theoretical force at 6 bar, advancing</b>	153 ... 3016 N	68 ... 754 N	68 ... 754 N
<b>Stroke</b>	10 ... 3000 mm	10 ... 4000 mm	10 ... 1500 mm
<b>Cushioning</b>	Pneumatic cushioning adjustable at both ends, shock absorber, hard characteristic curve	Elastic cushioning rings/pads at both ends, pneumatic cushioning adjustable at both ends	Elastic cushioning rings/pads at both ends, shock absorber, hard characteristic curve
<b>Position sensing</b>	Via proximity sensor, with attached displacement encoder, with integrated displacement encoder	Via proximity sensor	Via proximity sensor, via inductive sensors
<b>Description</b>	<ul style="list-style-type: none"> <li>• Recirculating ball bearing guide or heavy-duty guide</li> <li>• High precision and load capacity</li> <li>• Wide range of variants for customised applications</li> </ul>	<ul style="list-style-type: none"> <li>• Magnetic power transmission</li> <li>• Pressure-tight and zero leakage</li> <li>• Dirt-proof and dust-proof</li> </ul>	<ul style="list-style-type: none"> <li>• Magnetic power transmission</li> <li>• Recirculating ball bearing guide: combination of slide unit and rodless linear drive</li> <li>• Individual choice of end-position cushioning and sensing</li> </ul>
<b>online:</b> →	<a href="#">dgpl</a>	<a href="#">dgo</a>	<a href="#">slm</a>

## Software tool

### Mass moment of inertia

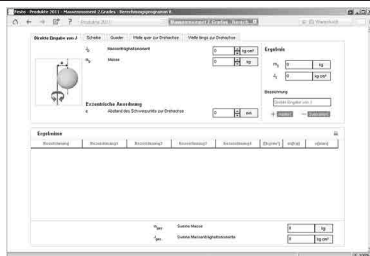



Juggling pencils and pocket calculators is now a thing of the past. Whether you have discs, blocks, push-on flanges, grippers, etc., this tool does the job of calculating all the mass moments of inertia. Just save, send or print and you're finished. This tool can be found



- either in the electronic catalogue by clicking on the blue button "Engineering"
- or on the DVD under Engineering Tools.



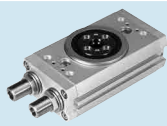

## Semi-rotary drives

	 <b>Semi-rotary drives DRVS</b>	 <b>Semi-rotary drives DSM, DSM-B, DSM-HD-B</b>	 <b>Semi-rotary drives DSR, DSRL</b>
<b>Size</b>	6, 8, 12, 16, 25, 32, 40	6, 8, 10, 12, 16, 25, 32, 40, 63	10, 12, 16, 25, 32, 40
<b>Theoretical torque at 6 bar</b>	0.15 ... 20 Nm	0.15 ... 80 Nm	0.5 ... 20 Nm
<b>Permissible mass moment of inertia</b>	6.5 ... 350 kgcm <sup>2</sup>	6.5 ... 5000 kgcm <sup>2</sup>	0 ... 150 kgcm <sup>2</sup>
<b>Position sensing</b>	Via proximity sensor	Without, via proximity sensor	Without
<b>Swivel angle</b>	0 ... 270°	0 ... 270°	0 ... 180°
<b>New</b>	<ul style="list-style-type: none"> <li>• With position sensor SRBS-Q1/Q12: quick to mount and infinitely adjustable</li> <li>• Push-on flange DARF and flange mounting DAMF□ versatile, quick and easy to mount</li> </ul>		
<b>Quick ordering of selected basic designs</b>	★		
<b>Description</b>	<ul style="list-style-type: none"> <li>• Double-acting semi-rotary drive with rotary vane</li> <li>• Lighter than other semi-rotary drives</li> <li>• Fixed swivel angle, adjustable swivel angle possible with the help of accessories</li> <li>• Housing protected against splash water and dust</li> </ul>	<ul style="list-style-type: none"> <li>• Semi-rotary vane drive</li> <li>• With spigot shaft, hollow flanged shaft, tandem rotary vane and spigot shaft, tandem rotary vane and flanged shaft or heavy-duty bearing (HD)</li> </ul>	<ul style="list-style-type: none"> <li>• Semi-rotary vane drive</li> <li>• With spigot or hollow flanged shaft</li> </ul>
<b>online: →</b>	<a href="#">drvs</a>	<a href="#">dsm</a>	<a href="#">dsr</a>

## Semi-rotary drives

	 <b>Semi-rotary drives DRRD</b>	 <b>Swivel/linear drive units DSL</b>
<b>Size</b>	8, 10, 12, 16, 20, 25, 32, 35, 40, 50, 63	16, 20, 25, 32, 40
<b>Theoretical torque at 6 bar</b>	0.2 ... 112 Nm	1.25 ... 20 Nm
<b>Permissible mass moment of inertia</b>	15 ... 420000 kgcm <sup>2</sup>	0.35 ... 40 kgcm <sup>2</sup>
<b>Position sensing</b>	Via proximity sensor	Via proximity sensor
<b>Swivel angle</b>	180°	0 ... 272°
<b>New</b>	<ul style="list-style-type: none"> <li>• Additionally available, attachable drive shaft – for even greater versatility when it comes to designing your connections</li> </ul>	
<b>Quick ordering of selected basic designs</b>	★	
<b>Description</b>	<ul style="list-style-type: none"> <li>• Twin-piston rotary drive, power transmission via rack and pinion principle</li> <li>• Very high accuracy in the end positions</li> <li>• Very high bearing load capacity</li> <li>• Very good axial run-out at the flanged shaft</li> </ul>	<ul style="list-style-type: none"> <li>• Rotary and linear motion can be controlled individually or simultaneously</li> <li>• High repetition accuracy</li> <li>• With plain or recirculating ball bearing guide</li> <li>• Through piston rod</li> </ul>
<b>online: →</b>	<a href="#">drrd</a>	<a href="#">dsl</a>



## Tandem and high-force cylinders

	 <b>High-force cylinders</b> <b>ADNH</b>	 <b>Tandem cylinders</b> <b>DNCT</b>
<b>Piston diameter</b>	25 mm, 40 mm, 63 mm, 100 mm	32 mm, 40 mm, 50 mm, 63 mm, 80 mm, 100, mm 125 mm
<b>Theoretical force at 6 bar, advancing</b>	1036 ... 18281 N	898 ... 14244 N
<b>Stroke</b>	1 ... 150 mm	2 ... 500 mm
<b>Description</b>	<ul style="list-style-type: none"> <li>• Mounting hole pattern to ISO 21287</li> <li>• Max. 4 cylinders can be combined</li> <li>• Thrust increase</li> <li>• Only 2 connections are required to pressurise all cylinders</li> <li>• Piston rod with male or female thread</li> <li>• For position sensing</li> </ul>	<ul style="list-style-type: none"> <li>• Mounting hole pattern to ISO 15552</li> <li>• Max. 2 cylinders can be combined</li> <li>• Thrust and return force increase</li> <li>• Piston rod with male thread</li> <li>• For position sensing</li> </ul>
<b>online: →</b>	<a href="#">adnh</a>	<a href="#">dnct</a>



## Multi-position cylinders

	 <b>Multi-position cylinder</b> <b>ADNM</b>
<b>Piston diameter</b>	25 mm, 40 mm, 63 mm, 100 mm
<b>Theoretical force at 6 bar, advancing</b>	295 ... 4712 N
<b>Max. total of all individual strokes</b>	1000 mm, 2000 mm
<b>Description</b>	<ul style="list-style-type: none"> <li>• Mounting hole pattern to ISO 21287</li> <li>• 2 ... 5 cylinders can be combined</li> <li>• Max. 5 positions can be approached</li> <li>• Piston rod with female or male thread</li> <li>• For position sensing</li> </ul>
<b>online: →</b>	<a href="#">adnm</a>



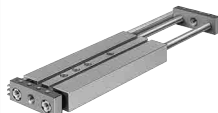

Drives with slides

	 <b>Mini slides DGSC</b>	 <b>Mini slides DGSL</b>	 <b>Mini slides SLF</b>
<b>Piston diameter</b>	6 mm	6 mm, 8 mm, 10 mm, 12 mm, 16 mm, 20 mm, 25 mm, 32 mm	6 mm, 10 mm, 16 mm
<b>Theoretical force at 6 bar, advancing</b>	17 N	17 ... 483 N	17 ... 121 N
<b>Stroke</b>	10 mm	10 ... 200 mm	10 ... 80 mm
<b>Cushioning</b>	Elastic cushioning rings/pads at both ends	Short elastic cushioning rings/pads at both ends, no cushioning, elastic cushioning rings/pads at both ends, elastic cushioning rings/pads at both ends with fixed stop, shock absorber, progressive, at both ends, shock absorber, self-adjusting, progressive, at both ends, with reducing sleeve	Elastic cushioning rings/pads at both ends
<b>Position sensing</b>	None	Via proximity sensor	Via proximity sensor
<b>Quick ordering of selected basic designs</b>		★	
<b>Description</b>	<ul style="list-style-type: none"> <li>• Smallest guided slide unit on the market</li> <li>• Precision ball bearing cage guide: reliable and high-quality process</li> <li>• Long service life thanks to housing made from high-alloy steel</li> <li>• Low break-away pressure and uniform movement thanks to minimal friction of guide and seal</li> </ul>	<ul style="list-style-type: none"> <li>• High load capacity and positioning accuracy</li> <li>• Maximum movement precision thanks to ground-in ball bearing cage guide</li> <li>• Maximum flexibility thanks to 8 sizes</li> <li>• Reliable in the event of pressure drop thanks to clamping cartridge or end-position locking</li> <li>• Wide variety of mounting and attachment options</li> <li>• Compact design</li> </ul>	<ul style="list-style-type: none"> <li>• Flat design</li> <li>• Ball bearing cage guide</li> <li>• Versatile mounting options</li> <li>• Easy adjustment of end positions</li> </ul>
<b>online: →</b>	<a href="#">dgsc</a>	<a href="#">dgsl</a>	<a href="#">slf</a>



Drives with slides

	 <b>Mini slides SLS</b>	 <b>Mini slides SLT</b>	 <b>Slide units SPZ</b>
<b>Piston diameter</b>	6 mm, 10 mm, 16 mm	6 mm, 10 mm, 16 mm, 20 mm, 25 mm	10 mm, 16 mm, 20 mm, 25 mm, 32 mm
<b>Theoretical force at 6 bar, advancing</b>	17 ... 121 N	34 ... 590 N	60 ... 724 N
<b>Stroke</b>	5 ... 30 mm	10 ... 200 mm	10 ... 100 mm
<b>Cushioning</b>	Elastic cushioning rings/pads at both ends	Shock absorber at both ends, elastic cushioning rings/pads at both ends	Elastic cushioning rings/pads at both ends with metal fixed stop
<b>Position sensing</b>	Via proximity sensor	Via proximity sensor	Via proximity sensor
<b>Description</b>	<ul style="list-style-type: none"> <li>• Flat design</li> <li>• Ball bearing cage guide</li> <li>• Versatile mounting options</li> </ul>	<ul style="list-style-type: none"> <li>• Powerful twin piston drive</li> <li>• Ball bearing cage guide</li> <li>• Versatile mounting options</li> <li>• Easy adjustment of end positions</li> </ul>	<ul style="list-style-type: none"> <li>• Twin-piston drive</li> <li>• High force with excellent protection against rotation</li> <li>• Plain or recirculating ball bearing guides</li> <li>• Widely spaced piston rods for high load capacity</li> </ul>
<b>online: →</b>	<a href="#">sls</a>	<a href="#">slt</a>	<a href="#">spz</a>



## 1 Drives with guide rods

	 <b>Guided drives</b> <b>DGRF</b>	 <b>Compact cylinders</b> <b>ADNGF</b>	 <b>Compact cylinders</b> <b>ADVUL</b>	 <b>Mini guided drives</b> <b>DFC</b>
<b>Piston diameter</b>	20 mm, 25 mm, 32 mm, 40 mm, 50 mm, 63 mm	12 mm, 16 mm, 20 mm, 25 mm, 32 mm, 40 mm, 50 mm, 63 mm, 80 mm, 100 mm	12 mm, 16 mm, 20 mm, 25 mm, 32 mm, 40 mm, 50 mm, 63 mm, 80 mm, 100 mm	4 mm, 6 mm, 10 mm
<b>Theoretical force at 6 bar, advancing</b>	189 ... 1870 N	68 ... 4712 N	51 ... 4712 N	7.5 ... 47 N
<b>Stroke</b>	10 ... 400 mm	1 ... 400 mm	1 ... 400 mm	5 ... 30 mm
<b>Cushioning</b>	Elastic cushioning rings/pads at both ends, self-adjusting pneumatic end-position cushioning, pneumatic cushioning adjustable at both ends	Elastic cushioning rings/pads at both ends, self-adjusting pneumatic end-position cushioning	Elastic cushioning rings/pads at both ends	Elastic cushioning rings/pads at both ends
<b>Position sensing</b>	Via proximity sensor	Via proximity sensor	Via proximity sensor	Without, via proximity sensor
<b>Description</b>	<ul style="list-style-type: none"> <li>• Easy-to-clean design</li> <li>• Increased corrosion protection</li> <li>• FDA-approved lubrication and sealing on the basic design</li> <li>• Hygienic mounting of the sensors possible</li> <li>• Compact design with high guide precision and load capacity</li> <li>• Long service life thanks to optional seal for unlubricated operation</li> <li>• Self-adjusting pneumatic end-position cushioning which adapts optimally to changes in load and speed</li> </ul>	<ul style="list-style-type: none"> <li>• Mounting hole pattern to ISO 21287</li> <li>• Piston rod secured against rotation by a guide rod and yoke plate</li> <li>• Plain-bearing guide</li> <li>• Optionally with through piston rod</li> <li>• For position sensing</li> </ul>	<ul style="list-style-type: none"> <li>• Piston rod secured against rotation by a guide rod and yoke plate</li> <li>• Plain-bearing guide</li> <li>• Optionally with through piston rod</li> <li>• For position sensing</li> </ul>	<ul style="list-style-type: none"> <li>• Smallest guided drive</li> <li>• High precision and load capacity</li> <li>• Minimal space requirement</li> <li>• Drive and guide unit in a single housing</li> <li>• Plain or recirculating ball bearing guides</li> </ul>
<b>online:</b> →	<a href="#">dgrf</a>	<a href="#">adngf</a>	<a href="#">advul</a>	<a href="#">dfc</a>

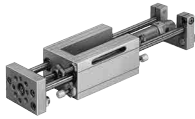
Drives with guide rods

	 <b>Guided drives DFM, DFM-B</b>	 <b>Twin-piston cylinders DPZ</b>	 <b>Twin-piston cylinders DPZJ</b>	 <b>Linear units SLE</b>
<b>Piston diameter</b>	12 mm, 16 mm, 20 mm, 25 mm, 32 mm, 40 mm, 50 mm, 63 mm, 80 mm, 100 mm	10 mm, 16 mm, 20 mm, 25 mm, 32 mm	10 mm, 16 mm, 20 mm, 25 mm, 32 mm	10 mm, 16 mm, 20 mm, 25 mm, 32 mm, 40 mm, 50 mm
<b>Theoretical force at 6 bar, advancing</b>	68 ... 4712 N	60 ... 966 N	60 ... 724 N	47 ... 1178 N
<b>Stroke</b>	10 ... 400 mm	10 ... 100 mm	10 ... 100 mm	10 ... 500 mm
<b>Cushioning</b>	Elastic cushioning rings/pads at both ends, pneumatic cushioning, adjustable at both ends, shock absorber, soft characteristic curve	Elastic cushioning rings/pads at both ends	Elastic cushioning rings/pads at both ends	Shock absorber, hard characteristic curve
<b>Position sensing</b>	Via proximity sensor	Via proximity sensor	Via proximity sensor	Via proximity sensor, via inductive sensors
<b>Quick ordering of selected basic designs</b>	★			
<b>Description</b>	<ul style="list-style-type: none"> <li>• Drive and guide unit in a single housing</li> <li>• High resistance to torques and lateral forces</li> <li>• Plain or recirculating ball bearing guides</li> <li>• Wide variety of mounting and attachment options</li> <li>• Wide range of variants for customised applications</li> </ul>	<ul style="list-style-type: none"> <li>• Twin pistons provide twice the force in half the space</li> <li>• Plain or recirculating ball bearing guides</li> <li>• Precision stroke adjustment in the end position</li> </ul>	<ul style="list-style-type: none"> <li>• With yoke plate on rear of cylinder for higher lateral forces and precision</li> <li>• Twin pistons provide twice the force in half the space</li> <li>• Plain or recirculating ball bearing guides</li> <li>• Precision stroke adjustment in the end position</li> </ul>	<ul style="list-style-type: none"> <li>• Combination of guide unit and standards-based cylinder</li> <li>• Multi-axis and drive combinations</li> <li>• Recirculating ball bearing guide</li> </ul>
<b>online: →</b>	<a href="#">dfm</a>	<a href="#">dpz</a>	<a href="#">dpzj</a>	<a href="#">sle</a>

## 1 Stopper cylinders

	 <b>Stopper cylinders</b> <b>DFSP</b>	 <b>Stopper cylinders</b> <b>DFST</b>	 <b>Stopper cylinders</b> <b>STAF</b>
<b>Piston diameter</b>	16 mm, 20 mm, 32 mm, 40 mm, 50 mm	50 mm, 63 mm, 80 mm	32 mm, 80 mm
<b>Impact force</b>	710 ... 6280 N	3000 ... 6000 N	480 ... 14600 N
<b>Stroke</b>	5 ... 30 mm	30 ... 40 mm	20 ... 40 mm
<b>Position sensing</b>	Via proximity sensor	Via proximity sensor	Via proximity sensor
<b>Toggle lever position sensing</b>		Via inductive sensor	
<b>Description</b>	<ul style="list-style-type: none"> <li>• Trunnion version with/without female thread, with/without protection against rotation</li> <li>• Roller version with protection against rotation</li> <li>• Compact design</li> <li>• Sensor slots on 3 sides</li> <li>• Long service life thanks to very good cushioning characteristics and sturdy piston rod guide</li> <li>• Workpiece carriers, pallets and packages weighing up to 90 kg can be safely stopped</li> </ul>	<ul style="list-style-type: none"> <li>• Toggle lever design</li> <li>• Integrated, adjustable shock absorber for smooth and adapted stopping</li> <li>• Up to 800 kg impact load</li> <li>• For position sensing on the piston</li> <li>• Lever locking mechanism</li> <li>• Toggle lever deactivator</li> </ul>	<ul style="list-style-type: none"> <li>• Roller version, toggle lever design</li> <li>• Absorption of high lateral forces</li> <li>• Direct mounting of solenoid valves on flange plate</li> </ul>
<b>online:</b> →	<a href="#">dfsp</a>	<a href="#">dfst</a>	<a href="#">staf</a>

## Clamping cylinders

	 <b>Clamping modules</b> <b>EV</b>
<b>Clamping area</b>	Ø12 mm, Ø16 mm, Ø20 mm, Ø25 mm, Ø32 mm, Ø40 mm, Ø50 mm, Ø63 mm, 10x30 mm, 15x40 mm, 15x63 mm, 20x75 mm, 20x120 mm, 20x180 mm
<b>Stroke</b>	3 ... 5 mm
<b>Description</b>	<ul style="list-style-type: none"> <li>• Compact rodless cylinder with diaphragm</li> <li>• Single-acting, with reset function</li> <li>• Flat design</li> <li>• Hermetically sealed</li> <li>• Pressure plates and foot mounting as accessories</li> </ul>
<b>online:</b> →	<a href="#">ev</a>

## Linear/swivel clamps



**Linear/swivel clamps**  
**CLR**

<b>Piston diameter</b>	12 mm, 16 mm, 20 mm, 25 mm, 32 mm, 40 mm, 50 mm, 63 mm
<b>Theoretical clamping force at 6 bar</b>	51 ... 1682 N
<b>Clamping stroke</b>	10 ... 50 mm
<b>Swivel angle</b>	90° +/- 2°, 90° +/- 3°, 90° +/- 4°
<b>Description</b>	<ul style="list-style-type: none"> <li>• Swivelling and clamping in one step</li> <li>• Adjustable swivel direction</li> <li>• Clamping fingers as accessories</li> <li>• Optionally with dust and welding spatter protection</li> <li>• Double-acting</li> <li>• For position sensing</li> </ul>
<b>online: →</b>	<a href="#">clr</a>

## Hinge cylinders



**Hinge cylinders**  
**DFAW**

**New**

<b>Piston diameter</b>	50 mm, 63 mm, 80 mm
<b>Stroke</b>	10 ... 200 mm
<b>Theoretical force at 6 bar, advancing</b>	1178 ... 3016 N
<b>Position sensing</b>	Via proximity sensor
<b>Cushioning</b>	Self-adjusting pneumatic end-position cushioning
<b>New</b>	<ul style="list-style-type: none"> <li>• Variants with clamping unit</li> </ul>
<b>Description</b>	<ul style="list-style-type: none"> <li>• Clamping of components during the welding process</li> <li>• Double-acting</li> <li>• Easy to mount thanks to swivel bearing on the bearing cap</li> <li>• Integrated flow control</li> <li>• Integrated, self-adjusting end-position cushioning</li> <li>• Variants with clamping unit</li> </ul>
<b>online: →</b>	<a href="#">dfaw</a>

## 1 Bellows cylinders



**Bellows cylinders**  
**EB**

<b>Size</b>	80, 145, 165, 215, 250, 325, 385
<b>Stroke</b>	20 ... 230 mm
<b>Description</b>	<ul style="list-style-type: none"> <li>• Use as a spring element or for reducing oscillations</li> <li>• Single- or double-bellows cylinder</li> <li>• High forces with a short stroke</li> <li>• Uniform movement: no stick-slip effect</li> <li>• Use in dusty environments or in water</li> <li>• Maintenance-free</li> </ul>
<b>online:</b> →	<a href="#">eb</a>

## Fluidic muscles



**Fluidic muscles**  
**DMSP**

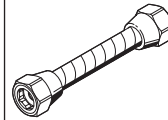

**Fluidic muscles**  
**MAS**

<b>Size</b>	5, 10, 20, 40	10, 20, 40
<b>Theoretical force at 6 bar</b>	140 ... 6000 N	480 ... 6000 N
<b>Nominal length</b>	30 ... 9000 mm	40 ... 9000 mm
<b>Max. contraction</b>	25% of nominal length, 20% of nominal length	25% of nominal length
<b>Description</b>	<ul style="list-style-type: none"> <li>• With press-fitted connection</li> <li>• Up to 30% less weight: a superb force/weight ratio</li> <li>• Single-acting, pulling</li> <li>• Three integrated adapter variants</li> <li>• 10 times the initial force of a comparable pneumatic cylinder</li> <li>• Uniform movement: no stick-slip effect</li> <li>• Hermetically sealed design offers protection against dust, dirt and fluids</li> </ul>	<ul style="list-style-type: none"> <li>• With screwed connection</li> <li>• Optionally with force retention</li> <li>• Single-acting, pulling</li> <li>• Use of customised mounting options</li> <li>• 10 times the initial force of a comparable pneumatic cylinder</li> <li>• Uniform movement: no stick-slip effect</li> <li>• Hermetically sealed design offers protection against dust, dirt and moisture</li> </ul>
<b>online:</b> →	<a href="#">dmsp</a>	<a href="#">mas</a>



Software tool

Rotary indexing table

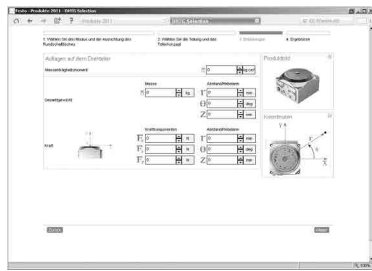

This tool helps you to select the right rotary indexing table of the type DHTG from Festo for your application. Let yourself be guided by the program – enter the general parameters and you will receive at least one suggestion for the product best suited to your application.

This tool can be found

- either in the electronic catalogue by clicking on the blue button “Engineering”
- or on the DVD under Engineering Tools.

Rotary indexing tables

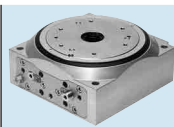

Rotary indexing tables  
DHTG



<b>Size</b>	65, 90, 140, 220
<b>Theoretical torque at 6 bar</b>	2.1 ... 58.9 Nm
<b>Indexing</b>	2 ... 24
<b>New</b>	<ul style="list-style-type: none"> <li>• Throughfeed for pneumatic and electrical energy</li> </ul>
<b>Description</b>	<ul style="list-style-type: none"> <li>• For swivelling or separating tasks</li> <li>• Sturdy mechanical system</li> <li>• Easy planning and commissioning</li> <li>• Rotary table diameters: 65, 90, 140, 220 mm</li> <li>• Free control of rotational direction</li> </ul>
<b>online: →</b>	<a href="#">dhtg</a>

Linear actuators for process automation



Linear actuators with displacement encoder  
DFPI



Linear actuators with displacement encoder  
DFPI-NB3P



Copac linear actuator  
DLP

<b>Design</b>	Piston rod, cylinder barrel	Piston rod, cylinder barrel	Piston rod
<b>Mode of operation</b>	Double-acting	Double-acting	Double-acting
<b>Size of valve actuator</b>	100, 125, 160, 200, 250, 320	100, 125, 160, 200, 250, 320	80, 100, 125, 160, 200, 250, 320
<b>Flange hole pattern</b>	F07, F10, F14		
<b>Operating pressure</b>	3 ... 8 bar	3 ... 8 bar	2 ... 8 bar
<b>Ambient temperature</b>	-20 ... 60 °C	-20 ... 80 °C	-20 ... 80 °C
<b>New</b>		<ul style="list-style-type: none"> <li>• Additional versions to ISO 15552</li> </ul>	
<b>Description</b>	<ul style="list-style-type: none"> <li>• Closed-loop controlled actuator for all linear process valves</li> <li>• Optionally with integrated positioner and valve block</li> <li>• Positional feedback via analogue 4 ... 20 mA signal for simple diagnostics</li> <li>• Easy integration into existing control architecture</li> <li>• Sturdy and compact housing for use outdoors</li> <li>• Connection for process valves to DIN 3358</li> </ul>	<ul style="list-style-type: none"> <li>• Standards-based linear actuators to ISO 15552</li> <li>• Easy connection to external positioners</li> <li>• Ideal for use in harsh ambient conditions</li> <li>• IP65, IP67, IP69K, NEMA4</li> <li>• ATEX 2GD certification</li> </ul>	<ul style="list-style-type: none"> <li>• NAMUR port pattern for solenoid valves to VDI/VDE 3845</li> <li>• Integrated air supply</li> <li>• Connection for process valves to DIN 3358</li> </ul>
<b>online: →</b>	<a href="#">dfpi</a>	<a href="#">dfpi</a>	<a href="#">dlp</a>

## 1 Quarter turn actuators for process automation



**Quarter turn actuators  
DFPD**



**Quarter turn actuators  
DAPS**

<b>Design</b>	Rack and pinion	Scotch yoke system
<b>Mode of operation</b>	Double-acting, single-acting	Double-acting, single-acting
<b>Size of valve actuator</b>	10, 20, 40, 80, 120, 160, 240, 300, 480	0008, 0015, 0030, 0053, 0060, 0090, 0106, 0120, 0180, 0240, 0360, 0480, 0720, 0960, 1440, 1920, 2880, 3840, 4000, 5760, 8000
<b>Flange hole pattern</b>	F03, F04, F05, F0507, F0710, F1012	F03, F04, F05, F07, F10, F12, F14, F16, F25
<b>Operating pressure</b>	2 ... 8 bar	1 ... 8.4 bar
<b>Ambient temperature</b>	-50 ... 150 °C	-50 ... 150 °C
<b>New</b>	<ul style="list-style-type: none"> <li>• New series</li> </ul>	
<b>Quick ordering of selected basic designs</b>	★	
<b>Description</b>	<ul style="list-style-type: none"> <li>• NAMUR port pattern for solenoid valves to VDI/VDE 3845</li> <li>• Flange hole pattern to ISO 5211</li> <li>• Uniform torque characteristic across the entire rotation angle range of 90°</li> <li>• Mounting hole pattern to VDI/VDE 3845</li> <li>• Increased corrosion protection</li> </ul>	<ul style="list-style-type: none"> <li>• High break-away torques</li> <li>• Approved in accordance with Directive 2014/34/EU (ATEX)</li> <li>• Flange hole pattern to ISO 5211</li> <li>• Mounting hole pattern to VDI/VDE 3845</li> <li>• Available with handwheel as a manual emergency override</li> <li>• Corrosion-resistant variant made from stainless steel</li> </ul>
<b>online: →</b>	<a href="#">dfpd</a>	<a href="#">daps</a>

## Cylinder/valve combinations



**Standards-based cylinders  
DNC-V**

<b>Mode of operation</b>	Double-acting
<b>Piston diameter</b>	32 mm, 40 mm, 50 mm, 63 mm, 80 mm, 100 mm
<b>Theoretical force at 6 bar, advancing</b>	415 ... 4712 N
<b>Stroke</b>	100 ... 2000 mm
<b>Cushioning</b>	Elastic cushioning rings/pads at both ends, pneumatic Cushioning, adjustable at both ends
<b>Description</b>	<ul style="list-style-type: none"> <li>• Mounting hole pattern to ISO 15552</li> <li>• Assembled and fitted with tubing ready for connection</li> <li>• Particularly suitable for decentralised use in larger systems</li> <li>• Valve variants: single or double solenoid valves, mounted on the right or left</li> <li>• For position sensing</li> <li>• Wide range of variants for customised applications</li> </ul>
<b>online: →</b>	<a href="#">dnc-v</a>

Software tool

Shock absorbers

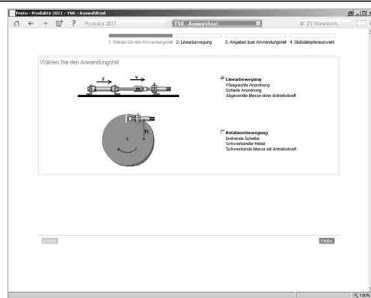

Whether diagonal or vertical, curved or straight, lever or disc, all types of cushioned movements are taken into account. The software tool always recommends the best shock absorber.



This tool can be found

- either in the electronic catalogue by clicking on the blue button “Engineering”
- or on the DVD under Engineering Tools.



Shock absorbers

	 Shock absorbers DYSR	 Shock absorbers YSR-C	 Shock absorbers YSRW	 Shock absorbers YSRW-DGC
<b>Stroke</b>	8 ... 60 mm	4 ... 60 mm	8 ... 34 mm	
<b>Max. energy absorption per stroke</b>	4 ... 384 J	0.6 ... 380 J	1.3 ... 70 J	
<b>Cushioning</b>	Adjustable	Self-adjusting	Self-adjusting, soft characteristic curve	Self-adjusting, soft characteristic curve
<b>Description</b>	<ul style="list-style-type: none"> <li>• Hydraulic shock absorber with spring return</li> <li>• Adjustable cushioning hardness</li> </ul>	<ul style="list-style-type: none"> <li>• Hydraulic shock absorber with path-controlled flow control function</li> <li>• Rapidly increasing cushioning force curve</li> <li>• Short cushioning stroke</li> <li>• Suitable for rotary drives</li> </ul>	<ul style="list-style-type: none"> <li>• Hydraulic shock absorber with path-controlled flow control function</li> <li>• Gently increasing cushioning force curve</li> <li>• Long cushioning stroke</li> <li>• Suitable for low-vibration operation</li> <li>• Short cycle times possible</li> </ul>	<ul style="list-style-type: none"> <li>• For linear drives DGC</li> <li>• Gently increasing cushioning force curve</li> <li>• Sizes: 12, 18, 25, 32, 40, 50, 63</li> </ul>
<b>online: →</b>	<a href="#">dysr</a>	<a href="#">ysr-c</a>	<a href="#">ysrw</a>	<a href="#">ysrw-dgc</a>



## Shock absorbers

	 <b>Shock absorbers YSRWJ</b>	 <b>Shock absorbers DYEF-Y1, DYEF-Y1F</b>	 <b>Shock absorbers DYSC</b>
<b>Stroke</b>	8 ... 14 mm	0.9 ... 7 mm	4 ... 25 mm
<b>Max. energy absorption per stroke</b>	1 ... 3 J	0.005 ... 1.2 J	0.6 ... 100 J
<b>Cushioning</b>	Self-adjusting, soft characteristic curve	Elastic cushioning rings/pads at both ends with metal fixed stop, elastic cushioning rings/pads at both ends without metal fixed stop	Self-adjusting
<b>Description</b>	<ul style="list-style-type: none"> <li>• Cushioning with self-adjusting, progressive hydraulic shock absorber</li> <li>• Gently increasing cushioning force curve</li> <li>• Adjustable cushioning stroke</li> <li>• End-position sensing with proximity sensor SME/SMT-8</li> <li>• Precision end-position adjustment</li> </ul>	<ul style="list-style-type: none"> <li>• Mechanical shock absorber with flexible rubber buffer</li> <li>• Elastic rubber buffer allows a defined metal end position</li> <li>• Adjustable cushioning hardness</li> <li>• Ideal for cushioning low energy</li> <li>• With precise metal end position</li> </ul>	<ul style="list-style-type: none"> <li>• Hydraulic shock absorber with path-controlled flow control function</li> <li>• Rapidly increasing cushioning force curve</li> <li>• Short cushioning stroke</li> <li>• Suitable for rotary drives</li> <li>• With metal fixed stop</li> </ul>
<b>online: →</b>	<a href="#">ysrwj</a>	<a href="#">dyef</a>	<a href="#">dysc</a>



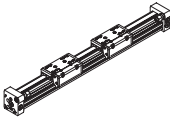

## Shock absorbers

	 <b>Shock absorbers DYSW</b>	 <b>Hydraulic cushioning cylinders DYHR</b>
<b>Stroke</b>	6 ... 20 mm	20 ... 60 mm
<b>Max. energy absorption per stroke</b>	0.8 ... 12 J	32 ... 384 J
<b>Cushioning</b>	Self-adjusting, soft characteristic curve	Adjustable
<b>Description</b>	<ul style="list-style-type: none"> <li>• Hydraulic shock absorber with path-controlled flow control function</li> <li>• Gently increasing cushioning force curve</li> <li>• Long cushioning stroke</li> <li>• Suitable for low-vibration operation</li> <li>• Short cycle times possible</li> <li>• With metal fixed stop</li> </ul>	<ul style="list-style-type: none"> <li>• Hydraulic cushioning cylinder for constant, slow braking speeds across the entire stroke</li> <li>• Braking speed can be precisely adjusted</li> <li>• Built-in compression spring returns the piston rod to the initial position</li> <li>• Suitable for slow feed speeds in the range up to 0.1 m/s</li> </ul>
<b>online: →</b>	<a href="#">dysw</a>	<a href="#">dyhr</a>

Accessories for pneumatic drives

	 <b>Guide units</b> FEN, FENG	 <b>Guide axes</b> DGC-FA	 <b>Guide axes</b> FDG	 <b>Clamping cartridge</b> KP
<b>Size</b>	8/10, 12/16, 20, 25, 32, 40, 50, 63, 80, 100	8 mm, 12 mm, 18 mm, 25 mm, 32 mm, 40 mm, 50 mm, 63 mm	18, 25, 32, 40, 50, 63	
<b>Stroke</b>	1 ... 500 mm	1 ... 8500 mm	1 ... 4500 mm	
<b>Round material to be clamped</b>				4 ... 32 mm
<b>Static holding force</b>				80 ... 7500 N
<b>Description</b>	<ul style="list-style-type: none"> <li>For protecting standards-based cylinders against rotation at high torque loads</li> <li>Plain or recirculating ball bearing guides</li> <li>High guide precision for workpiece handling</li> </ul>	<ul style="list-style-type: none"> <li>Without drive</li> <li>With recirculating ball bearing guide</li> <li>With guide and freely movable slide unit</li> <li>Increased torsional resistance</li> <li>Reduced vibrations with dynamic loads</li> <li>For supporting force and torque capacity in multi-axis applications</li> </ul>	<ul style="list-style-type: none"> <li>Without drive</li> <li>With recirculating ball bearing guide</li> <li>With guide and freely movable slide unit</li> <li>Increased torsional resistance</li> <li>Reduced vibrations with dynamic loads</li> <li>For supporting force and torque capacity in multi-axis applications</li> </ul>	<ul style="list-style-type: none"> <li>For in-house assembly of clamping units</li> <li>Not certified for use in safety-relevant control systems</li> </ul>
<b>online:</b> →	<a href="#">fen</a>	<a href="#">dgc-fa</a>	<a href="#">fdg</a>	<a href="#">kp</a>

Accessories for pneumatic drives

	 <b>Clamping units</b> KPE, KEC, KEC-S	 <b>Clamping units, clamping components</b> DADL	 <b>Mounting attachments</b>	 <b>Piston rod attachments</b>
<b>Size</b>		16, 20, 25, 32, 35, 40, 50, 63		
<b>Stroke</b>				
<b>Round material to be clamped</b>	4 ... 32 mm			
<b>Static holding force</b>	80 ... 8000 N			
<b>Quick ordering of selected basic designs</b>			★	★
<b>Description</b>	<ul style="list-style-type: none"> <li>KPE: ready-to-install combination of clamping cartridge KP and housing</li> <li>KEC: for use as a holding device (static application)</li> <li>KEC-S: for safety-related applications</li> </ul>	<ul style="list-style-type: none"> <li>Clamping unit DADL-EL: for semi-rotary drive DRRD, for mechanical locking in the end positions to prevent unwanted movement in unpressurised condition</li> <li>Clamping component DADL-EC: for semi-rotary drive DRRD, for securing an intermediate position in combination with the clamping unit DADL-EL</li> <li>Without drive</li> </ul>	<ul style="list-style-type: none"> <li>Mounting kits DARQ</li> <li>Direct mountings</li> <li>Foot mountings/Flange mountings</li> <li>Swivel mountings</li> <li>Clevis feet LNG, trunnion supports LNZ</li> <li>Slot nuts NST/NSTL</li> <li>Centring pins/sleeves NSTH</li> </ul>	<ul style="list-style-type: none"> <li>Rod clevises SG, CRSG</li> <li>Rod eyes SGS</li> <li>Coupling pieces KSG</li> <li>Self-aligning rod couplers FK</li> <li>Adapters AD</li> </ul>
<b>online:</b> →	<a href="#">kpe</a>	<a href="#">dadl</a>	<a href="#">n_015001</a>	<a href="#">n_03150</a>



### Drives with customised designs

Can't find the pneumatic drive you need in our catalogue? We can offer you customised components that are tailored to your specific requirements – from minor product modifications to complete new product developments. Common product modifications:

- Materials for special ambient conditions
- Customised dimensions
- Special strokes
- Customised mounting options
- Implementation of special cylinder functions (cylinder/valve combinations, single-acting principle, etc.)

Many additional variants are possible. Ask your Festo sales engineer, who will be happy to help.

Further information on customised components can be found on your local website

→ [www.festo.com](http://www.festo.com)

### Soft Stop

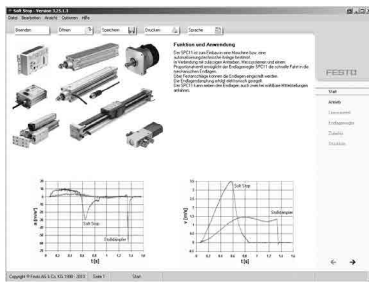





Soft Stop virtually makes the impossible possible. Travel times are reduced by as much as 30% for pneumatic drives and vibration is also greatly reduced. The selection program performs all of the necessary calculations.

This tool can be found

- either in the electronic catalogue by clicking on the blue button “Engineering”
- or on the DVD under Engineering Tools.

## Linear drives with displacement encoder

	 <b>Linear drives with displacement encoder DDLI</b>	 <b>Standards-based cylinders with displacement encoder DDPC</b>	 <b>Standards-based cylinders with displacement encoder DNCI</b>	 <b>Linear drives with displacement encoder DGCI</b>
<b>Piston diameter</b>	25, 32, 40, 63	80, 100	32, 40, 50, 63	18, 25, 32, 40, 63
<b>Theoretical force at 6 bar, advancing</b>	295 ... 1870 N	3016 ... 4712 N	415 ... 1870 N	153 ... 1870 N
<b>Max. load, horizontal</b>	30... 180 kg	300 ... 450 kg	45 ... 180 kg	300 ... 450 kg
<b>Max. load, vertical</b>	10 ... 60 kg	100 ... 150 kg	15 ... 60 kg	100 ... 150 kg
<b>Stroke</b>	100 ... 2000 mm	10 ... 2000 mm	10 ... 2000 mm	100 ... 2000 mm
<b>Description</b>	<ul style="list-style-type: none"> <li>• Based on linear drive DGC-K</li> <li>• Without guide</li> <li>• With displacement encoder for contactless measurement</li> <li>• Suitable for positioning with axis controller CPX-CMAX</li> <li>• Suitable for end-position control with end-position controller CPX-CMPX or SPC11</li> <li>• Can be used as a measuring cylinder</li> <li>• Supply ports on end face</li> </ul>	<ul style="list-style-type: none"> <li>• Standards-based cylinder to ISO 15552</li> <li>• With displacement encoder for contactless measurement</li> <li>• Suitable for positioning with axis controller CPX-CMAX</li> <li>• Suitable for end-position control with end-position controller CPX-CMPX or SPC11</li> <li>• Can be used as a measuring cylinder</li> <li>• Piston rod variants</li> <li>• Fixed cushioning</li> </ul>	<ul style="list-style-type: none"> <li>• Standards-based cylinder to ISO 15552</li> <li>• With integrated displacement encoder for relative analogue, contactless measurement</li> <li>• Suitable for servo-pneumatic applications with axis controller CPX-CMAX, end-position controller CPX-CMPX or SPC11 and measuring module CPX-CMIX</li> <li>• Piston rod with male thread</li> <li>• Piston rod variants</li> </ul>	<ul style="list-style-type: none"> <li>• With guide</li> <li>• With displacement encoder for absolute and contactless measuring</li> <li>• Suitable for servo-pneumatic applications with axis controller CPX-CMAX, end-position controller CPX-CMPX or SPC11 and measuring module CPX-CMIX</li> <li>• Supply ports optionally on end face or front</li> </ul>
<b>online: →</b>	<a href="#">ddli</a>	<a href="#">ddpc</a>	<a href="#">dnci</a>	<a href="#">dgci</a>

## Semi-rotary drives with displacement encoder

2



**Semi-rotary drives with angular displacement encoder  
DSMI**

<b>Piston diameter</b>	25, 40, 63
<b>Theoretical torque at 6 bar</b>	5 ... 40 Nm
<b>Max. mass moment of inertia, horizontal</b>	0.03 ... 0.6 kgm <sup>2</sup>
<b>Max. mass moment of inertia, vertical</b>	0.03 ... 0.6 kgm <sup>2</sup>
<b>Swivel angle</b>	0 ... 272°
<b>Description</b>	<ul style="list-style-type: none"> <li>• With rotary vane</li> <li>• Integrated rotary potentiometer</li> <li>• Suitable for servo-pneumatic applications with axis controller CPX-CMAX, end-position controller CPX-CMPX or SPC11 and measuring module CPX-CMIX</li> <li>• Compact design</li> </ul>
<b>online: →</b>	<a href="#">dsmi</a>

## Axis controllers



**Axis controllers  
CPX-CMAX**



**End-position controllers  
CPX-CMPX**





**End-position controllers  
SPC11**



<b>No. of axis strings</b>	1	1	1
<b>Axes per string</b>	1	1	1
<b>Description</b>	<ul style="list-style-type: none"> <li>• Axis controller as CPX module, supports pneumatic drives with piston rod, rodless drives and semi-rotary drives</li> <li>• Force and position control</li> <li>• Use with all fieldbus/Ethernet and controllers CEC available on CPX</li> <li>• Easy commissioning thanks to auto identification function</li> <li>• Rapid commissioning and comprehensive diagnostics with the parameterisation software FCT</li> </ul>	<ul style="list-style-type: none"> <li>• Electronic end-position control for pneumatic drives</li> <li>• Soft Stop for smooth braking and quick acceleration</li> <li>• Use with all fieldbus/Ethernet available on CPX</li> <li>• Easy commissioning with Festo plug and work</li> <li>• Approx. 30% shorter travel times and 30% less air consumption than with comparable standard pneumatics</li> </ul>	<ul style="list-style-type: none"> <li>• Quickly and smoothly into the end position with two additional intermediate positions</li> <li>• Electronic end-position cushioning</li> <li>• Quick and easy commissioning: configure, teach, done</li> <li>• Supports pneumatic drives with piston rod, rodless drives and semi-rotary drives</li> </ul>
<b>online: →</b>	<a href="#">cpx-cmax</a>	<a href="#">cpx-cmpx</a>	<a href="#">spc11</a>

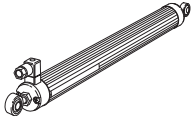

## Displacement encoders

	 <b>Displacement encoders</b> <b>MLO-POT-TLF</b>	 <b>Displacement encoders</b> <b>MLO-POT-LWG</b>	 <b>Displacement encoders</b> <b>MME-MTS-TLF</b>
<b>Stroke</b>	225 ... 2000 mm	100 ... 750 mm	225 ... 2000 mm
<b>Measuring principle of displacement encoder</b>	Analogue	Analogue	Digital
<b>Output signal</b>	Analogue	Analogue	CAN protocol type SPC-AIF
<b>Displacement resolution</b>	0.01 mm	0.01 mm	<0.01 mm
<b>Description</b>	<ul style="list-style-type: none"> <li>• Conductive plastic potentiometer</li> <li>• Absolute measurement with high resolution</li> <li>• High travel speed and long service life</li> <li>• Several mounting options on pneumatic linear drives DGPL</li> <li>• Plug-in connections</li> </ul>	<ul style="list-style-type: none"> <li>• Connecting rod potentiometer</li> <li>• Absolute measurement with high resolution</li> <li>• Long service life</li> <li>• High protection class</li> <li>• Plug-in connections</li> </ul>	<ul style="list-style-type: none"> <li>• Measuring principle: magnetostrictive</li> <li>• Contactless with absolute measurement</li> <li>• High travel speed</li> <li>• System product for servo-pneumatic positioning technology and Soft Stop</li> </ul>
<b>online: →</b>	<a href="#">mlo</a>	<a href="#">mlo</a>	<a href="#">mme</a>

## Proportional valves

	 <b>Proportional directional control valves</b> <b>VPWP</b>	 <b>Proportional directional control valves</b> <b>MPYE</b>
<b>Valve function</b>	5/3-way proportional directional control valve, closed	5/3-way, closed
<b>Pneumatic port 1</b>	G1/4, G1/8, G3/8	G1/4, G1/8, G3/8, M5
<b>Operating pressure for positioning/Soft Stop</b>	4 ... 8 bar	
<b>Operating pressure</b>	0 ... 10 bar	0 ... 10 bar
<b>Standard nominal flow rate</b>	350 ... 2000 l/min	100 ... 2000 l/min
<b>Description</b>	<ul style="list-style-type: none"> <li>• Regulated piston spool valve</li> <li>• Digital actuation</li> <li>• Integrated pressure sensors for monitoring function and force control</li> <li>• With auto identification</li> <li>• Diagnostic function</li> <li>• Integrated digital output, e. g. for a clamping/brake unit</li> <li>• Suitable for servo-pneumatic applications with CPX-CMAX and CPX-CMPX</li> </ul>	<ul style="list-style-type: none"> <li>• Regulated piston spool valve</li> <li>• Analogue actuation</li> <li>• Setpoint input as analogue voltage signal (0 ... 10 V)</li> <li>• Suitable for servo-pneumatic applications with SPC11</li> </ul>
<b>online: →</b>	<a href="#">vpwp</a>	<a href="#">mpye</a>

## Sensor interfaces

2



**Sensor interfaces**  
**CASM**



**Measured-value transducers**  
**DADE**

<b>Diagnostic function</b>	Display via LED	Display via LED
<b>Electrical connection, displacement encoder</b>	M12, socket, 8-pin, 5-pin	M12, socket, 8-pin
<b>Electrical connection, control interface</b>	M9, plug connector, 5-pin	
<b>Control interface</b>	Digital, CAN bus with Festo protocol, without terminating resistor	
<b>Description</b>	<ul style="list-style-type: none"> <li>• For actuating pneumatic positioning drives with the latest servo-pneumatic systems such as CPX-CMAX, CPX-CMPX and CPX-CMIX</li> <li>• Short cables for analogue signals, secure digitised bus transmission</li> <li>• Convenient plug and work concept with auto identification and comprehensive diagnostics</li> <li>• High protection class IP67</li> </ul>	<ul style="list-style-type: none"> <li>• For standards-based cylinders DNCl and DDPC</li> <li>• Converts sensor signals into voltage or current signals</li> <li>• Diagnostic display via LED</li> <li>• Mounting via through-holes</li> </ul>
<b>online:</b> →	<a href="#">casm</a>	<a href="#">dade</a>

Software tool

**PositioningDrives**







Which electromechanical linear drive best meets your needs? Enter the data for your application, such as position values, effective loads and mounting position, and the software suggests a number of solutions.

This tool can be found

- either in the electronic catalogue by clicking on the blue button “Engineering”
- or on the DVD under Engineering Tools.

Linear drives and slide units



	 <b>Electric cylinders</b> <b>EPCO</b>	 <b>Electric cylinders</b> <b>ESBF</b>	 <b>Spindle axes</b> <b>EGC-BS</b>	 <b>Toothed belt axes</b> <b>EGC-HD-TB</b>
<b>Size</b>	16, 25, 40	32, 40, 50, 63, 80, 100	70, 80, 120, 185	125, 160, 220
<b>Max. feed force Fx</b>	50 ... 650 N	1000 ... 17000 N	300 ... 3000 N	450 ... 1800 N
<b>Repeat accuracy</b>	+/-0.02	+/-0.01, +/-0.015, +/-0.05	+/-0.02	
<b>Stroke</b>	1 ... 400 mm	100 ... 400 mm	50 ... 3000 mm	50 ... 5000 mm
<b>Description</b>	<ul style="list-style-type: none"> <li>• Linear drive with permanently attached motor</li> <li>• With ball screw</li> <li>• Optional: encoder, holding brake and female thread on the piston rod</li> <li>• Two different spindle pitches for high force or high speed</li> <li>• Suitable for simple applications in factory automation that in the past were mostly carried out using pneumatic solutions</li> <li>• Cost-optimised</li> <li>• Precision and backlash-free guide</li> </ul>	<ul style="list-style-type: none"> <li>• Available as spindle drive with ball screw (size 32 ... 100) or lead screw (size 32 ... 50)</li> <li>• Optional: high corrosion protection, protection class IP65, suitable for use in the food industry (see supplementary information on materials at <a href="http://www.festo.com/sp">www.festo.com/sp</a> &gt; Certificates), piston rod extension</li> <li>• Ball screw: three spindle pitches make it possible to select the optimal force-speed ratio</li> <li>• Ball screw: high rigidity and precision</li> <li>• Axial or parallel motor mounting</li> </ul>	<ul style="list-style-type: none"> <li>• Recirculating ball bearing guide for high loads and torques</li> <li>• Optionally with clamping unit, at one or both ends</li> <li>• Profile with optimised rigidity</li> <li>• Various spindle pitches</li> <li>• The spindle support enables maximum travel speed</li> <li>• Axial or parallel motor mounting</li> </ul>	<ul style="list-style-type: none"> <li>• With heavy-duty guide</li> <li>• For maximum loads and torques and high feed forces</li> <li>• Precise and resilient DUO guide</li> <li>• Motor can be mounted on any one of 4 sides</li> </ul>
<b>online:</b> →	<a href="#">epco</a>	<a href="#">esbf</a>	<a href="#">egc</a>	<a href="#">egc</a>

## Linear drives and slides



3

	 <b>Toothed belt axes EGC-TB</b>	 <b>Spindle axes EGC-HD-BS</b>	 <b>Mini slides EGSL</b>	 <b>Mini slides SLTE</b>
<b>Size</b>	50, 70, 80, 120, 185	125, 160, 220	35, 45, 55, 75	10, 16
<b>Max. feed force F<sub>x</sub></b>	50 ... 2500 N	300 ... 1300 N	75 ... 450 N	
<b>Repeat accuracy</b>	+/-0.08, +/-0.1	+/-0.02	+/-0.015	+/-100.000
<b>Stroke</b>	50 ... 8500 mm	50 ... 2400 mm	50 ... 300 mm	50 ... 150 mm
<b>Description</b>	<ul style="list-style-type: none"> <li>• Recirculating ball bearing guide for high loads and torques</li> <li>• Optionally with clamping unit, at one or both ends</li> <li>• Profile with optimised rigidity</li> </ul>	<ul style="list-style-type: none"> <li>• With heavy-duty guide</li> <li>• With integrated ball screw</li> <li>• For maximum loads and torques, high feed forces and speeds and long service life</li> <li>• Precision DUO guide rail with high load capacity</li> </ul>	<ul style="list-style-type: none"> <li>• Very high rated slide loads, ideal for vertical applications such as press-fitting or joining</li> <li>• Reliable: the completely closed spindle stops dirt or stray small parts getting into the guide area</li> <li>• Flexible: motor can be attached laterally or axially, in this case turned by 4 x 90°</li> </ul>	<ul style="list-style-type: none"> <li>• Electromechanical linear axis with lead screw</li> <li>• With DC servo motor</li> <li>• Easy actuation via I/O interface, PROFIBUS, CANopen, DeviceNet</li> <li>• Precise and rigid guide</li> </ul>
<b>online:</b> →	<a href="#">egc</a>	<a href="#">egc</a>	<a href="#">egsl</a>	<a href="#">slte</a>

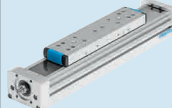
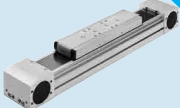

## Linear drives and slides

	 <b>Electric slides EGSK</b>	 <b>Electric slides EGSP</b>	 <b>New</b> <b>Spindle axes ELGA-BS-KF</b>	 <b>New</b> <b>Toothed belt axes ELGA-TB-KF</b>
<b>Size</b>	15, 20, 26, 33, 46	20, 26, 33, 46	70, 80, 120, 150	70, 80, 120, 150
<b>Max. feed force F<sub>x</sub></b>	19 ... 392 N	69 ... 466 N	300 ... 3000 N	260 ... 2000 N
<b>Repeat accuracy</b>	+/-0.003 - +/-0.004, +/-0.003 - +/-0.01, +/-0.01	+/-0.003 - +/-0.01	+/-0.02	+/-0.08, +/-0.1
<b>Stroke</b>	25 ... 840 mm	25 ... 840 mm	50 ... 3000 mm	50 ... 8500 mm
<b>New</b>			• New series	• Suitable for use in the food industry as per supplementary information on materials
<b>Description</b>	<ul style="list-style-type: none"> <li>• Electromechanical linear axis with ball screw</li> <li>• Recirculating ball bearing guide and ball screw without caged ball bearings</li> <li>• Standardised mounting interfaces</li> <li>• Compact design</li> <li>• High rigidity</li> </ul>	<ul style="list-style-type: none"> <li>• Electromechanical linear axis with ball screw</li> <li>• Recirculating ball bearing guide with caged ball bearings</li> <li>• Size 33, 46: ball screw with caged ball bearings</li> <li>• Low maintenance</li> <li>• Uniform operating behaviour with very low noise levels</li> <li>• Standardised mounting interfaces</li> <li>• Compact design</li> <li>• High rigidity</li> </ul>	<ul style="list-style-type: none"> <li>• Internal, precision recirculating ball bearing guide with high load capacity for high torque loads</li> <li>• Guide and ball screw protected by cover strip</li> <li>• Precise and resilient guide</li> <li>• For the highest requirements in terms of feed force and accuracy</li> <li>• Speeds up to 2 m/s with high acceleration up to 15 m/s<sup>2</sup></li> <li>• Space-saving position sensing</li> <li>• Flexible motor connection</li> </ul>	<ul style="list-style-type: none"> <li>• Internal, precision recirculating ball bearing guide with high load capacity for high torque loads</li> <li>• Guide and toothed belt protected by cover band</li> <li>• Precision guide rail with high load capacity</li> <li>• Speeds up to 5 m/s with high acceleration up to 50 m/s<sup>2</sup></li> <li>• High feed forces</li> <li>• Flexible motor connection</li> </ul>
<b>online:</b> →	<a href="#">egsk</a>	<a href="#">egsp</a>	<a href="#">elga</a>	<a href="#">elga</a>

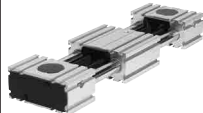
Linear drives and slides



	 <b>Toothed belt axes ELGA-TB-G</b>	 <b>Toothed belt axes ELGA-TB-RF</b>	 <b>Toothed belt axes ELGG</b>	 <b>Toothed belt axes ELGR</b>
<b>Size</b>	70, 80, 120	70, 80, 120	35, 45, 55	35, 45, 55
<b>Max. feed force Fx</b>	350 ... 1300 N	260 ... 1000 N	50 ... 350 N	50 ... 350 N
<b>Repeat accuracy</b>	+/-0.08	+/-0.08	+/-0.1	+/-0.1
<b>Stroke</b>	50 ... 8500 mm	50 ... 7400 mm	50 ... 1200 mm	50 ... 1500 mm
<b>Description</b>	<ul style="list-style-type: none"> <li>• Integrated plain-bearing guide</li> <li>• For small and medium loads</li> <li>• Low guide backlash</li> <li>• Driving component for external guides</li> <li>• Speeds up to 5 m/s with high acceleration up to 50 m/s<sup>2</sup></li> <li>• Flexible motor connection</li> <li>• Motor can be mounted on 4 sides</li> </ul>	<ul style="list-style-type: none"> <li>• Integrated roller bearing guide</li> <li>• High speeds up to 10 m/s with high acceleration up to 50 m/s<sup>2</sup></li> <li>• Guide backlash = 0 mm</li> <li>• Very good operating behaviour under torque load</li> <li>• Sturdy alternative to the recirculating ball bearing guide</li> <li>• As an actuator for external guides, especially for high speeds</li> <li>• Motor can be mounted on 4 sides</li> </ul>	<ul style="list-style-type: none"> <li>• Toothed belt axis with two opposing slides</li> <li>• With low-cost plain bearing and precise ball bearing guide</li> <li>• Optional central support improves the rigidity</li> <li>• Motor can be mounted on 4 sides</li> </ul>	<ul style="list-style-type: none"> <li>• Optimum price/performance ratio</li> <li>• Ready-to-install unit for quick and easy design</li> <li>• With plain or recirculating ball bearing guide</li> <li>• Motor can be mounted on 4 sides</li> <li>• Also available as OMS product</li> </ul>
<b>online:</b> →	<a href="#">elga</a>	<a href="#">elga</a>	<a href="#">elgg</a>	<a href="#">elgr</a>

Linear drives and slides



	 <b>Cantilever axes DGEA-ZR</b>	 <b>Toothed belt axes DGE-ZR, DGE-ZR-KF, DGE-ZR-HD</b>	 <b>Toothed belt axes DGE-ZR-RF</b>
<b>Size</b>	18, 25, 40	8, 12, 18, 25, 40, 63	25, 40, 63
<b>Max. feed force Fx</b>	230 ... 1000 N	15 ... 1500 N	260 ... 1500 N
<b>Repeat accuracy</b>	+/-0.05	+/-0.08, +/-0.1	+/-0.1
<b>Stroke</b>	1 ... 1000 mm	1 ... 4500 mm	1 ... 5000 mm
<b>Description</b>	<ul style="list-style-type: none"> <li>• Toothed belt drive with recirculating ball bearing guide</li> <li>• Dynamic cantilever operation</li> <li>• Stationary drive head</li> </ul>	<ul style="list-style-type: none"> <li>• Electromechanical axis with toothed belt; DGE-ZR: without guide; DGE-ZR-KF: with recirculating ball bearing guide</li> <li>• Optional protected version</li> </ul>	<ul style="list-style-type: none"> <li>• Electromechanical axis with toothed belt and internal roller bearing guide</li> <li>• High speeds possible</li> </ul>
<b>online:</b> →	<a href="#">dgea</a>	<a href="#">dge-zr</a>	<a href="#">dge-zr</a>

## Linear drives and slides

3

		
	<b>Spindle axes DGE-SP</b>	<b>Positioning axes DMES</b>
<b>Size</b>	18, 25, 40, 63	18, 25, 40, 63
<b>Max. feed force Fx</b>	140 ... 1600 N	240 ... 3000 N
<b>Repeat accuracy</b>	+/-0.02	+/-0.05, +/-0.07
<b>Stroke</b>		50 ... 1800 mm
<b>Description</b>	<ul style="list-style-type: none"> <li>• Without guide or with recirculating ball bearing guide</li> <li>• Optional protected version</li> </ul>	<ul style="list-style-type: none"> <li>• Mechanical linear drive with lead screw</li> <li>• Basic version or with recirculating ball bearing guide</li> <li>• High feed forces of up to 3000 N</li> </ul>
<b>online: →</b>	<a href="#">dge-sp</a>	<a href="#">dmes</a>

## Semi-rotary drives



		
	<b>Rotary drives ERMO</b>	<b>Rotary modules ERMB</b>
<b>Size</b>	12, 16, 25, 32	20, 25, 32
<b>Max. driving torque</b>	0.15 ... 5 Nm	0.7 ... 8.5 Nm
<b>Max. input speed</b>	50 ... 100 1/min	900 ... 1350 1/min
<b>Rotation angle</b>	Infinite	Infinite
<b>Description</b>	<ul style="list-style-type: none"> <li>• Electric rotary drive with stepper motor and integrated gear unit</li> <li>• ServoLite – closed-loop operation with encoder</li> <li>• Heavy-duty bearing for high forces and torques</li> <li>• Backlash-free pre-stressed rotating plate with very good axial eccentricity and concentricity properties</li> <li>• Quick and accurate installation</li> <li>• For simple rotary indexing table applications and as a rotary axis in multi-axis applications</li> </ul>	<ul style="list-style-type: none"> <li>• Electromechanical rotary module with toothed belt</li> <li>• Compact design</li> <li>• Mounting interfaces on all sides</li> <li>• Stable output shaft bearings</li> <li>• Unlimited and flexible rotation angle</li> </ul>
<b>online: →</b>	<a href="#">ermo</a>	<a href="#">ermb</a>

## Electric handling modules

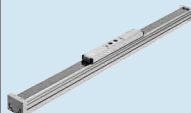

	
	<b>Rotary/lifting modules EHMB</b>
<b>Size</b>	20, 25, 32
<b>Max. driving torque</b>	0.7 ... 6.7 Nm
<b>Max. input speed</b>	900 ... 1350 1/min
<b>Rotation angle</b>	Infinite
<b>Description</b>	<ul style="list-style-type: none"> <li>• Complete module with combined and configurable rotary/lifting movement</li> <li>• Dynamic, flexible, economical thanks to the modular drive concept for the linear movement</li> <li>• Hollow axis with large internal diameter makes laying power supply lines easy, convenient and safe</li> </ul>
<b>online: →</b>	<a href="#">ehmb</a>

Linear guides

3

		 <b>New</b>	
	<b>Guide units</b> <b>EAGF</b>	<b>Guide axes</b> <b>ELFA</b>	<b>Guide axes</b> <b>ELFR</b>
<b>Size</b>	16, 25, 32, 40, 50, 63, 80, 100	70, 80	35, 45, 55
<b>Stroke</b>	1 ... 500 mm	50 ... 7000 mm	50 ... 1500 mm
<b>Guide</b>	Recirculating ball bearing guide	Roller bearing guide	Plain-bearing guide, recirculating ball bearing guide
<b>New</b>		<ul style="list-style-type: none"> <li>• New series</li> </ul>	
<b>Description</b>	<ul style="list-style-type: none"> <li>• For electric cylinders EPCO and ESBF</li> <li>• For absorption of high process forces and torques</li> <li>• High guide precision</li> </ul>	<ul style="list-style-type: none"> <li>• For drive axis ELGA</li> <li>• For supporting forces and torques in multi-axis applications</li> <li>• Increased torsional resistance</li> <li>• Reduced vibrations with dynamic loads</li> </ul>	<ul style="list-style-type: none"> <li>• Driveless guide unit with guide and freely movable slide</li> <li>• For supporting forces and torques in multi-axis applications</li> <li>• Increased torsional resistance</li> </ul>
<b>online:</b> →	<a href="#">eagf</a>	<a href="#">elfa</a>	<a href="#">elfr</a>

Linear guides

		
	<b>Guide axes</b> <b>EGC-FA</b>	<b>Guide axes</b> <b>FDG-ZR-RF</b>
<b>Size</b>	70, 80, 120, 185	25, 40, 63
<b>Stroke</b>	50 ... 8500 mm	1 ... 5000 mm
<b>Guide</b>	Recirculating ball bearing guide	Roller bearing guide
<b>Description</b>	<ul style="list-style-type: none"> <li>• Driveless guide unit with guide and freely movable slide</li> <li>• For supporting forces and torques in multi-axis applications</li> <li>• Increased torsional resistance</li> </ul>	<ul style="list-style-type: none"> <li>• Driveless linear guide unit with guide and freely movable slide unit</li> <li>• For supporting forces and torques in multi-axis applications</li> <li>• Increased torsional resistance</li> </ul>
<b>online:</b> →	<a href="#">egc</a>	<a href="#">fdg</a>

Customised components – for your specific requirements

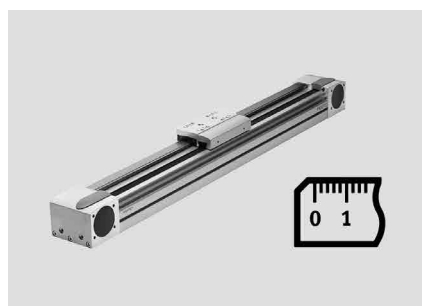

**Drives with customised designs**

Can't find the electromechanical drive you need in our catalogue? We can offer you customised components that are tailored to your specific requirements – from minor product modifications to complete new product developments. Common product modifications:

- Special strokes
- Design for special ambient conditions
- Design optimised for the fitting space
- Design with opposing carriages
- Design with absolute encoder

Many additional variants are possible. Ask your Festo sales engineer, who will be happy to help.

Further information on customised components can be found on your local website

→ [www.festo.com](http://www.festo.com)

4

### Festo Configuration Tool (FCT)

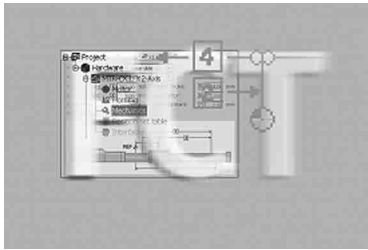

FCT is a configuration and parameterisation software program that supports all Festo devices, in particular motor controllers. It is extremely flexible, provides full support for the device properties and is simple and intuitive to operate. The user is guided step-by-step through the commissioning process while each individual step is checked. The parameterisation software can be found on the website under Support > Support Portal > enter search term.

### CODESYS





CODESYS for standardised programming of embedded devices according to IEC 61131-3. It makes your life easier with simple commissioning, fast programming and parameterisation. The benefits:

- Hardware-neutral software platform for quick and easy configuration, programming and commissioning of pneumatic and electrical automation solutions
- Extensive module libraries for single or multi-axis positioning motions
- The IEC 61131-3 standard means that CODESYS is flexible and open for all types of control tasks
- Modular: offline and online functions as well as components for hardware configuration and visualisation
- User-friendly IEC function block extension
- Re-use of existing application parts

The parameterisation software can be found on the website under Support > Support Portal > enter search term.

## Servo motors

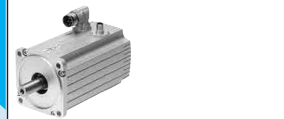
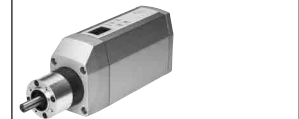
	 <b>Integrated drives</b> <b>EMCA</b>	 <b>Servo motors</b> <b>EMME-AS</b>	 <b>Servo motor</b> <b>EMMS-AS</b>	 <b>Motor units</b> <b>MTR-DCI</b>
<b>Nominal torque</b>	0.37 ... 0.45 Nm	0.12 ... 6.4 Nm	0.14 ... 22.63 Nm	
<b>Nominal speed</b>	3100 ... 3150 1/min	3000 ... 9000 1/min	2000 ... 10300 1/min	3000 ... 3250 1/min
<b>Peak torque</b>	0.85 ... 0.91 Nm	0.7 ... 30 Nm	0.5 ... 120 Nm	
<b>Maximum speed</b>	3300 ... 3500 1/min	3910 ... 10000 1/min	2210 ... 23040 1/min	3000 ... 3300 1/min
<b>New</b>	<ul style="list-style-type: none"> <li>• New series</li> </ul>	<ul style="list-style-type: none"> <li>• Additional versions</li> </ul>		
<b>Description</b>	<ul style="list-style-type: none"> <li>• 64 freely programmable position sets</li> <li>• Multi-turn encoder with buffering (resolution up to 32 bits or &gt; 4 billion revolutions)</li> <li>• Degree of protection IP54 as standard, with IP65 available as an option, for direct installation in the system</li> <li>• Actuation via CANopen, EtherNet/IP and I/O interface</li> </ul>	<ul style="list-style-type: none"> <li>• Brushless, permanently excited synchronous servo motor</li> <li>• Digital absolute displacement encoder, single-turn or multi-turn</li> <li>• Reliable, dynamic, precise</li> <li>• Optimised connection technology</li> <li>• Over 40 types in stock</li> <li>• Available with holding brake</li> </ul>	<ul style="list-style-type: none"> <li>• Permanently excited, electrodynamic, brushless servo motor</li> <li>• Digital absolute displacement encoder, single-turn or multi-turn</li> <li>• 66 stock types</li> <li>• 490 built-to-order variants</li> <li>• Optionally with holding brake, IP65, resolver</li> <li>• Various winding variants</li> </ul>	<ul style="list-style-type: none"> <li>• DC motor with encoder</li> <li>• Gear unit, controller, power electronics integrated</li> <li>• Gear ratios: 7:1, 14:1, 22:1</li> <li>• RS232 parameterisation interface</li> <li>• I/O, PROFIBUS, CANopen, PROFIBUS DP, DeviceNet interface</li> <li>• Control panel with display, optional</li> </ul>
<b>online: →</b>	<a href="#">emca</a>	<a href="#">emme</a>	<a href="#">emms</a>	<a href="#">mtr</a>



## Stepper motors



**Stepper motors**  
**EMMS-ST**

<b>Maximum speed</b>	430 ... 6000 1/min
<b>Motor holding torque</b>	0.09 ... 9.3 Nm
<b>Description</b>	<ul style="list-style-type: none"> <li>• Small increment and high driving torques thanks to 2-phase hybrid technology</li> <li>• Optimised connection technology</li> <li>• 28 types in stock</li> <li>• With incremental encoder for closed-loop operation</li> <li>• Available with holding brake</li> </ul>
<b>online:</b> →	<a href="#">emms</a>

4

## Controllers for AC servo motors





**Motor controllers**  
**CMMP-AS-M0, CMMP-AS-M3**

<b>Nominal current</b>	2 ... 13 A
<b>Nominal operating voltage AC</b>	230 ... 400 V
<b>Nominal operating voltage phases</b>	1-phase, 3-phase
<b>Rated output of controller</b>	500 ... 9000 VA
<b>Fieldbus coupling</b>	PROFIBUS DP, CANopen, DeviceNet, EtherCAT, EtherNet/IP, Modbus/TCP, PROFINET
<b>New</b>	<ul style="list-style-type: none"> <li>• Additional variant</li> </ul>
<b>Description</b>	<ul style="list-style-type: none"> <li>• Many interfaces and functions for decentral motion functions (flying saw, flying measurement, modulo function, etc.)</li> <li>• For cam disk controllers and highly dynamic movements</li> <li>• Standardised interfaces allow seamless integration in mechatronic multi-axis modular systems</li> <li>• Reliable and easy commissioning and parameterisation with the Festo Configuration Tool (FCT)</li> <li>• Optionally with 3 slots for switch or safety module, for extension module</li> <li>• Integrated process interfaces: Modbus/TCP, CAN bus and digital I/O module</li> <li>• Further extension modules: PROFIBUS, PROFINET, EtherCAT®, etc.</li> </ul>
<b>online:</b> →	<a href="#">cmm</a>



## Controllers for DC servo motors

	
	<b>Motor controllers</b> <b>SFC-DC</b>
<b>Nominal current, load supply</b>	3 A
<b>Nominal voltage, load supply DC</b>	24 V
<b>Rated output of controller</b>	75 VA
<b>Fieldbus coupling</b>	PROFIBUS DP, CANopen, DeviceNet
<b>Description</b>	<ul style="list-style-type: none"> <li>• For actuating mini slide SLTE and parallel gripper HGPLE</li> <li>• Easy actuation via I/O interface, PROFIBUS, CANopen, DeviceNet</li> <li>• With or without control panel</li> <li>• Parameterisation via control panel or parameterisation software FCT</li> <li>• Field controller with protection class IP54</li> <li>• Reliable and easy commissioning and parameterisation with the Festo Configuration Tool (FCT)</li> </ul>
<b>online: →</b>	<a href="#">sfc-dc</a>

## Controllers for stepper motors

			
	<b>Controllers</b> <b>CMXH</b>	<b>Motor controllers</b> <b>CMMO-ST</b>	<b>Motor controllers</b> <b>CMMS-ST</b>
<b>Nominal current, load supply</b>	10 A	6 A	8 A
<b>Max. step frequency</b>			4 kHz
<b>Controller operating mode</b>	Direct mode, record selection	PWM MOSFET power output stage, cascade controller with P position controller, PI speed controller, PI current controller	PWM MOSFET power output stage
<b>Fieldbus coupling</b>	1x CANopen Slave	Ethernet	PROFIBUS DP, CANopen
<b>New</b>	<ul style="list-style-type: none"> <li>• New series</li> </ul>		
<b>Description</b>	<ul style="list-style-type: none"> <li>• For controlling two servo motors</li> <li>• For controlling planar surface gantries</li> <li>• Supports the Safe Torque Off (STO) safety function</li> <li>• Simple actuation via digital I/O interface, CAN interface or Ethernet TCP/IP</li> <li>• H-rail mounting possible</li> <li>• Parameterisation with the Festo Configuration Tool (FCT)</li> </ul>	<ul style="list-style-type: none"> <li>• Motor controller of the Optimised Motion Series (for EPCO, ELGR, ERMO)</li> <li>• With convenient FCT commissioning for stepper motor EMMS-ST</li> <li>• Simple and quick parameters configuration via web browser and parameter cloud</li> <li>• Reliable and easy commissioning and parameterisation with the Festo Configuration Tool (FCT)</li> <li>• Simple control via digital I/O, IO-Link®, I-Port, Modbus TCP</li> <li>• Safety function Safe Torque Off (STO) PLe</li> <li>• Sinusoidal current injection for especially silent motor operation</li> </ul>	<ul style="list-style-type: none"> <li>• For controlling stepper motors EMMS-ST and Optimised Motion Series (for EPCO, ELGR, ERMO)</li> <li>• Easy and convenient: commissioning and firmware updates via SD card slot</li> <li>• Reliable and easy commissioning and parameterisation with the Festo Configuration Tool (FCT)</li> <li>• Integrated process interface: digital I/O, CAN, RS485</li> <li>• Safety function Safe Torque Off (STO) PLd</li> <li>• Optional: PROFIBUS and DeviceNet®</li> </ul>
<b>online: →</b>	<a href="#">cmxh</a>	<a href="#">cmmo</a>	<a href="#">cmms</a>

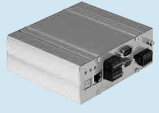
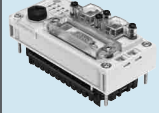
## Multi-axis controllers

	 <b>Controllers</b> <b>CMXH-ST2</b>	 <b>Motor controllers</b> <b>CPX-CEC-C1, CPX-CEC-M1</b>	 <b>Controllers</b> <b>CECX-X-C1, CECX-X-M1</b>
<b>CPU data</b>		256 MB RAM, 32 MB flash, 400 MHz, 800 MHz processor	64 MB DRAM, Processor 400 MHz
<b>Configuration support</b>	FCT (Festo Configuration Tool)	CODESYS V2.3, CODESYS V3	
<b>Processing time</b>		Approx. 200 µs/1 k instruction	
<b>Degree of protection</b>	IP20	IP65, IP67	IP20
<b>New</b>	<ul style="list-style-type: none"> <li>New series</li> </ul>	<ul style="list-style-type: none"> <li>One platform for fluid and motion control with modules for cloud connection via OPC UA</li> </ul>	
<b>Description</b>	<ul style="list-style-type: none"> <li>The ideal controller for controlling planar surface gantries EXCM</li> <li>Supports the Safe Torque Off (STO) safety function</li> <li>Easy control via digital I/O interface, CAN interface or Ethernet TCP/IP</li> </ul>	<ul style="list-style-type: none"> <li>Easy actuation of valve terminal configurations</li> <li>Programming with CODESYS to IEC 61131-3</li> <li>Connection to all fieldbuses as a remote controller and for pre-processing</li> <li>Actuation of electric drives via CANopen</li> <li>SoftMotion functions for coordinated multi-axis movements</li> </ul>	<ul style="list-style-type: none"> <li>Modular master controller with CODESYS or motion controller with CODESYS and SoftMotion.</li> <li>Programming to standard IEC 61131-3</li> <li>Three plug-in slots for optional modules</li> <li>Optional: communication module for PROFIBUS</li> </ul>
<b>online: →</b>	<a href="#">cmxh</a>	<a href="#">cpx-cec-m1</a>	<a href="#">cecx-x</a>

## Positioners for process automation

	 <b>Positioners</b> <b>CMSX</b>
<b>Standard nominal flow rate</b>	50 ... 130 l/min
<b>Ambient temperature</b>	-5 ... 60 °C
<b>Reference value</b>	0-10, 0-20 mA, 4-20 mA
<b>Operating pressure</b>	3 ... 8 bar
<b>Safety note</b>	Adjustable; holding, opening, closing
<b>New</b>	<ul style="list-style-type: none"> <li>Additional versions</li> </ul>
<b>Quick ordering of selected basic designs</b>	★
<b>Description</b>	<ul style="list-style-type: none"> <li>For position control of double-acting pneumatic quarter turn actuators in process automation systems</li> <li>Simple and efficient position control based on the PID control algorithm</li> <li>Suitable for quarter turn actuators with a swivel angle of approx. 90° and a mechanical interface in accordance with VDI/VDE Directive 3845</li> <li>Power supply 24 V DC</li> </ul>
<b>online: →</b>	<a href="#">cmsx</a>

## Safety systems

4



**Safety modules  
CAMC**

<b>Safety function</b>	Safe Brake Control (SBC), Safe Speed Range (SSR), Safe Speed Monitor (SSM), Safe Torque Off (STO), Safely Limited Speed (SLS), Safe Torque off (STO), Safe Operating Stop (SOS), Safe Stop 1 (SS1), Safe Stop 2 (SS2)
<b>Safety Integrity Level (SIL)</b>	Safe Brake Control (SBC)/SIL 3, Safely Limited Speed (SLS)/SIL 3, Safe Operating Stop (SOS)/SIL 3, Safe Stop 1 (SS1)/SIL 3, Safe Stop 2 (SS2)/SIL 3, Safe Speed Monitor (SSM)/SIL 3, Safe Speed Range (SSR)/SIL 3, Safe Torque Off (STO)/SIL 3, Safe Torque Off (STO)/SIL 3 / SILCL 3
<b>Characteristics of logic inputs</b>	Electrically isolated, 4 safe, 2-channel inputs equivalent/antivalent switching, configurable test pulses, configurable function, 6 safe, 1-channel inputs, configurable test pulses
<b>Number of digital logic inputs</b>	2, 10
<b>Digital output design</b>	Potential-free signal contact, 3 safe, 2-channel semiconductor outputs
<b>Description</b>	<ul style="list-style-type: none"> <li>• Plug-in module</li> <li>• For motor controller CMMP-AS-...-M3</li> </ul>
<b>online: →</b>	<a href="#">camc</a>

## Gear units



**Gear units  
EMGC**



**Gear units  
EMGA-SST**



**Gear units  
EMGA-EAS**



**Gear units  
EMGA-SAS**

	EMGC	EMGA-SST	EMGA-EAS	EMGA-SAS
<b>Continuous output torque</b>	2 ... 44 Nm	11 ... 110 Nm	11 ... 110 Nm	11 ... 450 Nm
<b>Max. input speed</b>	4500 ... 6000 1/min	7000 ... 18000 1/min	7000 ... 18000 1/min	6500 ... 18000 1/min
<b>Torsional rigidity</b>	0.105 ... 2.4 Nm/arcmin	1 ... 6 Nm/arcmin	1 ... 6 Nm/arcmin	1 ... 38 Nm/arcmin
<b>Backlash</b>	0.5 ... 0.67°	0.12 ... 0.25°	0.12 ... 0.25°	0.1 ... 0.25°
<b>Mass moment of inertia, gear unit</b>	0.04 ... 0.4 kgcm <sup>2</sup>	0.019 ... 0.77 kgcm <sup>2</sup>	0.019 ... 0.77 kgcm <sup>2</sup>	0.019 ... 12.14 kgcm <sup>2</sup>
<b>Max. efficiency</b>	90%, 92%, 94%	98%	98%	98%
<b>New</b>	<ul style="list-style-type: none"> <li>• New series</li> </ul>			
<b>Description</b>	<ul style="list-style-type: none"> <li>• Planetary gear units, one-stage or two-stage, for integrated drives EMCA</li> <li>• Gear ratio i = 3 to i = 40, available ex-stock</li> <li>• Life-time lubrication</li> </ul>	<ul style="list-style-type: none"> <li>• Planetary gear units for stepper motors EMMS-ST</li> <li>• Gear ratio i = 3 and i = 5, available ex-stock</li> <li>• Life-time lubrication</li> </ul>	<ul style="list-style-type: none"> <li>• Planetary gear unit for servo motors EMMS-AS</li> <li>• Gear ratio i = 3 and i = 5, available ex-stock</li> <li>• Life-time lubrication</li> </ul>	<ul style="list-style-type: none"> <li>• Planetary gear units for servo motors EMMS-AS</li> <li>• Gear ratio i = 3 and i = 5, available ex-stock</li> <li>• Life-time lubrication</li> </ul>
<b>online: →</b>	<a href="#">emgc</a>	<a href="#">emga</a>	<a href="#">emga</a>	<a href="#">emga</a>

## Power supply units



**Power supply units**  
**CACN**

<b>Nominal output voltage DC</b>	24 ... 48 V
<b>Nominal output current</b>	5 ... 20 A
<b>Input voltage range AC</b>	100 ... 500 V
<b>Input current</b>	0.9–1.65 A, 1.5–3.0 A, 2.2–1.2 A, 2.3–1.9 A, 5.1–2.3 A
<b>Mains buffering</b>	24 ... 110 ms
<b>Description</b>	<ul style="list-style-type: none"> <li>• H-rail mounting</li> <li>• Mounting position: free convection</li> </ul>
<b>online:</b> →	<a href="#">cacn</a>

### Product finder for grippers







A secure grip is a question of the right calculation. In this case, calculation of weight, direction of movement, distances, etc. The software tool immediately determines which type of gripper – parallel, three-point, angle or swivel/gripper – and which size best matches your requirements.

This tool can be found



- either in the electronic catalogue by clicking on the blue button “Product finder”
- or on the DVD under Engineering Tools.

5

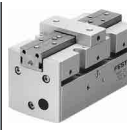

## Parallel grippers

	 <b>Parallel grippers DHPS</b>	 <b>Parallel grippers HGPD</b>	 <b>Electric parallel grippers HGPLE</b>	 <b>Parallel grippers HGPT</b>
<b>Total gripping force at 6 bar, closing</b>	25 ... 910 N	94 ... 3716 N		106 ... 6300 N
<b>Stroke per gripper jaw</b>	2 ... 12.5 mm	3 ... 20 mm	30 ... 80 mm	1.5 ... 25 mm
<b>Position sensing</b>	Via Hall sensor, via proximity sensor	Via proximity sensor	Via integrated angular displacement encoder	Via proximity sensor
<b>Gripping force backup</b>	During opening, during closing	During opening, during closing		During opening, during closing
<b>Description</b>	<ul style="list-style-type: none"> <li>• Heavy-duty, precision T-slot guide for gripper jaws</li> <li>• High gripping force with compact size</li> <li>• Max. repetition accuracy</li> <li>• Wide range of options for mounting on drive units</li> </ul>	<ul style="list-style-type: none"> <li>• Ideal for very harsh environments</li> <li>• Precise gripping even at high torque load</li> <li>• Max. gripping force with optimum installation space/force ratio</li> <li>• 8 sizes with up to 40 mm total stroke</li> <li>• Repetition accuracy of 0 ... 0.05 mm</li> </ul>	<ul style="list-style-type: none"> <li>• Electrically actuated gripper with long stroke</li> <li>• Free, speed-controlled selection of gripping positions</li> <li>• Long stroke allows use with workpieces of different sizes</li> <li>• Adjustable gripping force for highly sensitive and large, heavy workpieces</li> <li>• Very high torque resistance, very high accuracy</li> <li>• Short opening and closing times</li> <li>• Minimal installation costs</li> </ul>	<ul style="list-style-type: none"> <li>• Sturdy and powerful</li> <li>• With T-slot guide</li> <li>• Suitable for external and internal gripping</li> <li>• Gripper jaw guide protected by sealing air against dust</li> <li>• High-force variant available</li> </ul>
<b>online: →</b>	<a href="#">dhps</a>	<a href="#">hgpd</a>	<a href="#">hgple</a>	<a href="#">hgpt</a>

## Parallel grippers



	 Parallel grippers HGPL	 Parallel grippers HGPP	 Parallel grippers HGPC
<b>Total gripping force at 6 bar, closing</b>	158 ... 2742 N	80 ... 830 N	44 ... 126 N
<b>Stroke per gripper jaw</b>	20 ... 150 mm	2 ... 12.5 mm	3 ... 7 mm
<b>Position sensing</b>	Via proximity sensor	Via Hall sensor, via inductive sensors	Via proximity sensor
<b>Gripping force backup</b>		During opening, during closing	During closing
<b>New</b>	<ul style="list-style-type: none"> <li>• With expanded range of sensors</li> </ul>		
<b>Description</b>	<ul style="list-style-type: none"> <li>• Space-saving, high forces and torques</li> <li>• Controlled, precise and centred gripping</li> <li>• Long stroke: long guide length for the gripper jaws</li> <li>• Suitable for external and internal gripping</li> <li>• Opening stroke can be adjusted to optimise time</li> </ul>	<ul style="list-style-type: none"> <li>• High-precision gripper jaw guide</li> <li>• Suitable for external and internal gripping</li> <li>• Very flexible thanks to versatile attachment, mounting and application options</li> </ul>	<ul style="list-style-type: none"> <li>• Compact, low cost, reliable operation, long service life</li> <li>• High force with minimal volume</li> <li>• Suitable for external and internal gripping</li> </ul>
<b>online: →</b>	<a href="#">hgpl</a>	<a href="#">hgpp</a>	<a href="#">hgpc</a>

## Parallel grippers



	 Parallel grippers HGP	 Parallel grippers HGPM
<b>Total gripping force at 6 bar, closing</b>	160 ... 340 N	16 ... 35 N
<b>Stroke per gripper jaw</b>	5 ... 7.5 mm	2 ... 3 mm
<b>Position sensing</b>	Via proximity sensor	None
<b>Gripping force backup</b>		
<b>Description</b>	<ul style="list-style-type: none"> <li>• Double-acting piston drive</li> <li>• High gripping force with compact size</li> <li>• Self-centring</li> <li>• Suitable for external and internal gripping</li> <li>• With protective dust cap for use in dusty environments (protection class IP54)</li> <li>• Max. repetition accuracy</li> <li>• Internal fixed flow control</li> <li>• Versatile thanks to externally adaptable gripper fingers</li> <li>• Wide range of options for mounting on drive units</li> </ul>	<ul style="list-style-type: none"> <li>• Micro gripper: compact, handy design</li> <li>• Versatile thanks to externally adaptable gripper fingers</li> <li>• Mounting options with clamping spigot, with flange mounting, with Z stroke compensation</li> </ul>
<b>online: →</b>	<a href="#">hgp</a>	<a href="#">hgpm</a>

## Three-point grippers

5



	 <b>Three-point grippers DHDS</b>	 <b>Three-point grippers HGDT</b>	 <b>Three-point grippers HGDD</b>
<b>Total gripping force at 6 bar, closing</b>	87 ... 750 N	207 ... 2592 N	336 ... 2745 N
<b>Stroke per gripper jaw</b>	2.5 ... 6 mm	1.5 ... 10 mm	4 ... 12 mm
<b>Position sensing</b>	Via Hall sensor, via proximity sensor	Via proximity sensor	Via proximity sensor
<b>Gripping force backup</b>	During closing	During opening, during closing	During opening, during closing
<b>Description</b>	<ul style="list-style-type: none"> <li>• Heavy-duty, precision T-slot guide for gripper jaws</li> <li>• High gripping force with compact size</li> <li>• Max. repetition accuracy</li> <li>• Wide range of options for mounting on drive units</li> </ul>	<ul style="list-style-type: none"> <li>• Synchronous movement of the gripper jaws</li> <li>• With T-slot guide</li> <li>• Suitable for external and internal gripping</li> <li>• Gripper jaw guide protected by sealing air against dust</li> <li>• High-force variant available</li> </ul>	<ul style="list-style-type: none"> <li>• Precise gripping with centric movements despite high torque loads</li> <li>• Ideal for very harsh environments</li> <li>• 5 sizes with up to 12 mm stroke/jaw</li> <li>• Repetition accuracy of 0 ... 0.05 mm</li> </ul>
<b>online: →</b>	<a href="#">hgds</a>	<a href="#">hgdt</a>	<a href="#">hgdd</a>

## Angle grippers

	 <b>Angle grippers DHWS</b>	 <b>Angle grippers HGWC</b>	 <b>Angle grippers HGWM</b>
<b>Total gripping torque at 6 bar, closing</b>	30 ... 1362 Ncm	22 ... 144 Ncm	22 ... 64 Ncm
<b>Max. opening angle</b>	40°	30 ... 80°	14 ... 18.5°
<b>Position sensing</b>	Via Hall sensor, via proximity sensor	Via proximity sensor	None
<b>Gripping force backup</b>	During closing		
<b>Description</b>	<ul style="list-style-type: none"> <li>• Improved gripper jaw guide</li> <li>• Link guided movement</li> <li>• Internal fixed flow control, does away with the need for external flow control in 90% of applications</li> <li>• Max. repetition accuracy</li> <li>• Wide range of options for mounting on drive units</li> </ul>	<ul style="list-style-type: none"> <li>• High force with minimal volume</li> <li>• Internal fixed flow control, does away with the need for external flow control in 90% of applications</li> <li>• Suitable for external and internal gripping</li> <li>• Repetition accuracy 0.05 mm</li> <li>• Compact and cost-effective</li> </ul>	<ul style="list-style-type: none"> <li>• Micro gripper: compact, handy design</li> <li>• Mounting options with clamping spigot, with flange mounting, with Z stroke compensation</li> <li>• Versatile thanks to externally adaptable gripper fingers</li> </ul>
<b>online: →</b>	<a href="#">dhws</a>	<a href="#">hgwc</a>	<a href="#">hgwm</a>



## Radial grippers

	 <b>Radial grippers DHRS</b>	 <b>Radial grippers HGRT</b>	 <b>Radial grippers HGRC</b>
<b>Total gripping torque at 6 bar, closing</b>	15 ... 660 Ncm	158 ... 7754 Ncm	22 ... 144 Ncm
<b>Max. opening angle</b>	180°	180°	180°
<b>Position sensing</b>	Via Hall sensor, via proximity sensor	Via proximity sensor, via inductive sensors	Via proximity sensor
<b>Description</b>	<ul style="list-style-type: none"> <li>• Lateral gripper jaw support for high torque loads</li> <li>• Self-centring</li> <li>• Gripper jaw centring options</li> <li>• Max. repetition accuracy</li> </ul>	<ul style="list-style-type: none"> <li>• Secure gripping thanks to precise, polished plain-bearing guides</li> <li>• Gripping force backup via compression springs holds the gripped workpiece securely in the event of pressure failure</li> <li>• Compression spring also boosts the gripping force for applications involving heavier loads</li> <li>• Optimum cycle times thanks to freely adjustable opening angle of up to max. 90° per gripper finger. This prevents possible collisions due to the gripper jaws opening too wide</li> </ul>	<ul style="list-style-type: none"> <li>• High force with minimal volume</li> <li>• Internal fixed flow control, does away with the need for external flow control in 90% of applications</li> <li>• Suitable for external and internal gripping</li> <li>• Repetition accuracy 0.05 mm</li> <li>• Compact and cost-effective</li> </ul>
<b>online: →</b>	<a href="#">dhrs</a>	<a href="#">hgrt</a>	<a href="#">hgrc</a>

5

## Swivel/gripper units

	 <b>Swivel/gripper units HGDS</b>
<b>Total gripping force at 6 bar, closing</b>	74 ... 168 N
<b>Stroke per gripper jaw</b>	2.5 ... 7 mm
<b>Swivel angle</b>	210°
<b>Position sensing, gripper</b>	Via proximity sensor
<b>Description</b>	<ul style="list-style-type: none"> <li>• Combination of parallel gripper and swivel module</li> <li>• Swivel angle infinitely adjustable</li> <li>• Precise end stop with elastic cushioning or integrated shock absorber</li> </ul>
<b>online: →</b>	<a href="#">hgds</a>

## Bellows grippers



**Bellows grippers**  
**DHEB**

<b>Stroke of bellows</b>	3.5 ... 25 mm
<b>Min. diameter to be gripped</b>	8 ... 66 mm
<b>Max. diameter to be gripped</b>	11 ... 85 mm
<b>Max. operating frequency of gripper</b>	≤4 Hz
<b>Description</b>	<ul style="list-style-type: none"> <li>• 11 sizes for gripping diameter from 8 to 85 mm</li> <li>• Direction of movement: bellows upwards or downwards</li> <li>• Different bellows materials: EPDM or silicone</li> <li>• Air connection on the side or from above</li> <li>• Optimised process sequence with increased quality: prevents the workpieces from being scratched</li> <li>• Additional reliability: optional sensing via proximity or position sensor</li> </ul>
<b>online: →</b>	<a href="#">dheb</a>

5

## Gripper accessories

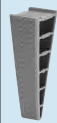

**Adaptive gripper fingers**  
**DHAS**

**New**

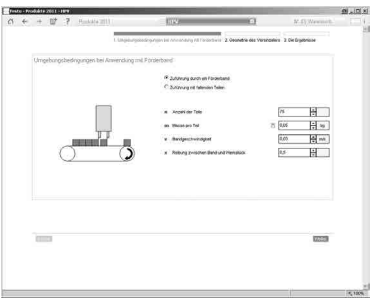

<b>New</b>	<ul style="list-style-type: none"> <li>• New series</li> </ul>
<b>Description</b>	<ul style="list-style-type: none"> <li>• Self-adjusting to different workpiece shapes</li> <li>• Adaptive gripper fingers for smooth and flexible gripping, with the Fin Ray Effect® derived from the movement of a fish's tail fin</li> <li>• Sizes 60, 80, 120</li> <li>• For workpiece diameters from 6 to 120 mm</li> </ul>
<b>online: →</b>	<a href="#">dhas</a>

Software tool

<b>Feed separators</b>		<p>This tool helps you to select the right separator of the type HPV from Festo for your application. Let yourself be guided by the program – enter the general parameters and you will receive at least one suggestion for the product best suited to your application.</p> <p>This tool can be found</p> <ul style="list-style-type: none"> <li>• either in the electronic catalogue by clicking on the blue button “Engineering”</li> <li>• or on the DVD under Engineering Tools.</li> </ul>
------------------------	---	--

5

Feed separators

	 <p><b>Feed separators HPVS</b></p>	 <p><b>Feed separators HPV</b></p>
<b>Mode of operation</b>	Double-acting	Double-acting
<b>Piston diameter</b>	10 mm, 14 mm, 22 mm	10 mm, 14 mm, 22 mm
<b>Stroke</b>	10 ... 60 mm	10 ... 60 mm
<b>Theoretical force at 6 bar, advancing</b>	45 ... 225 N	45 ... 225 N
<b>Description</b>	<ul style="list-style-type: none"> <li>• Version with one plunger</li> <li>• With non-rotating piston rod</li> <li>• Proximity sensor SME/SMT-8 can be integrated in the housing</li> </ul>	<ul style="list-style-type: none"> <li>• Version with two plungers</li> <li>• With twin piston, non-rotating piston rod and locking mechanism</li> <li>• Cost-effective: replaces at least two drives in the feed process</li> <li>• Proximity sensor SME/SMT-8 can be integrated in the housing</li> </ul>
<b>online: →</b>	<a href="#">hpvs</a>	<a href="#">hpv</a>

### Configurator

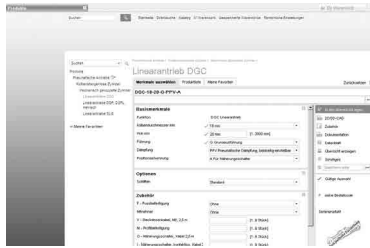

Design a product with numerous features reliably and quickly with the help of the configurator. Select all the required product features step-by-step. The use of logic checks ensures that only correct configurations are available for selection. The configurator is part of the electronic catalogue and is not available as a separate software program.

## 6 Handling modules



**Handling modules  
HSP**



**Handling modules, pneumatic  
HSW-AP, HSW-AS**

<b>Size</b>	12, 16, 25	10, 12, 16
<b>Theoretical force at 6 bar</b>	40 ... 65 N	30 ... 55 N
<b>Min. cycle time</b>	0.6 ... 1 s	0.6 ... 1 s
<b>Y stroke</b>	52 ... 170 mm	
<b>Z stroke</b>	20 ... 70 mm	80 ... 100 mm
<b>Repeat accuracy</b>	+/-0.01, +/-0.02	
<b>Description</b>	<ul style="list-style-type: none"> <li>• Function module for the automatic transfer, feeding and removal of small parts in extremely confined spaces</li> <li>• Guided vertical and horizontal motion sequence</li> <li>• High precision and rigidity</li> <li>• Compact design</li> <li>• Extremely short cycle times</li> <li>• Cost-optimised</li> <li>• Stroke adjustment along Y- and Z-axes</li> </ul>	<ul style="list-style-type: none"> <li>• Function module for the automatic transfer, feeding and removal of small parts in extremely confined spaces</li> <li>• Guided swivel and linear motion</li> <li>• High precision and good rigidity</li> <li>• HSW-AP: pneumatic, with swivel module DSM; HSW-AS: without drive, with drive shaft</li> <li>• Fast and compact</li> <li>• Low-cost and ideal for universal use</li> </ul>
<b>online:</b> →	<a href="#">hsp</a>	<a href="#">hsw</a>

## Software tool

### Configurator: Handling Guide Online (HGO)







Planning complex handling systems takes a lot of time. You can use the “Handling Guide Online” (HGO) configurator to design a customised handling system for your application in just a few steps.

#### Advantages :

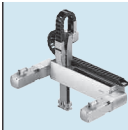

- Automatic selection of all relevant components
- Automatic design and calculation of the workload
- CAD model available immediately
- Fully automated processing
- Fully assembled or unassembled systems This tool can be found in the electronic catalogue by clicking on the blue button “Engineering”.

Cartesian systems

	 <b>Single-axis system</b> <b>YXCS</b>	 <b>2D linear gantry</b> <b>YXCL</b>	 <b>Linear gantries</b> <b>EXCT</b>	 <b>2D planar surface gantry</b> <b>YXCF</b>
<b>New</b>			<b>New</b>	
<b>Description</b>	<ul style="list-style-type: none"> <li>• Ready-to-install single-axis solution including energy chain for cable and tubing routing as well as matching motor and motor controller package</li> <li>• For any single-axis movement</li> <li>• Ideal for long gantry strokes and heavy loads</li> <li>• High mechanical rigidity and sturdy design</li> </ul>	<ul style="list-style-type: none"> <li>• Ideal for long gantry strokes and heavy loads</li> <li>• High mechanical rigidity and sturdy design</li> <li>• Frequently used in feeding or loading applications</li> <li>• Use of tried and tested drives/axes from Festo</li> </ul>	<ul style="list-style-type: none"> <li>• New series</li> <li>• Short cycle times thanks to high dynamic response</li> <li>• Perfectly matched drive and controller package for quick commissioning</li> <li>• Especially economical due to the low moving dead weight</li> </ul>	<ul style="list-style-type: none"> <li>• Can be used universally for handling light to heavy workpieces or high effective loads</li> <li>• Especially suitable for very long strokes</li> <li>• High mechanical rigidity and sturdy design</li> <li>• Freely positionable; any intermediate positions</li> </ul>
<b>online:</b> →	<a href="#">yxcs</a>	<a href="#">yxcl</a>	<a href="#">exct</a>	<a href="#">yxcf</a>

6

Cartesian systems

	 <b>2D planar surface gantry</b> <b>EXCM</b>	 <b>2D planar surface gantry</b> <b>EXCH</b>	 <b>3D gantry</b> <b>YXCR</b>
<b>New</b>		<b>New</b>	
<b>Description</b>	<ul style="list-style-type: none"> <li>• Additional size</li> <li>• Excellent functionality in confined spaces</li> <li>• Small moving loads</li> <li>• Actuation via two stepper motors with integrated optical encoder and two-axis controller</li> <li>• With plain or recirculating ball bearing guide</li> </ul>	<ul style="list-style-type: none"> <li>• New series</li> <li>• Optimal dynamic response when compared with other Cartesian gantry systems</li> <li>• Drive concept with low moving dead weight</li> <li>• Flat system design</li> <li>• High acceleration in both axial directions</li> </ul>	<ul style="list-style-type: none"> <li>• Can be used universally for handling light to heavy workpieces or high effective loads</li> <li>• Especially suitable for very long strokes</li> <li>• High mechanical rigidity and sturdy design</li> <li>• Pneumatic and electric components – freely combinable</li> <li>• As an electrical solution – freely positionable/any intermediate positions</li> </ul>
<b>online:</b> →	<a href="#">excm</a>	<a href="#">exch</a>	<a href="#">yxcr</a>

## Parallel kinematic systems



**Tripod  
EXPT**

<b>Max. payload</b>	5 kg
<b>Working space nominal diameter</b>	450 ... 1200 mm
<b>Working space nominal height</b>	100 mm
<b>Max. picking rate</b>	150 picks/min in 12" cycle
<b>Description</b>	<ul style="list-style-type: none"> <li>• Low moving mass – ideal for demanding requirements on dynamic response in three dimensions</li> <li>• Great path accuracy with a range of path profiles, even for very dynamic operation</li> </ul>
<b>online: →</b>	<a href="#">expt</a>

6

## Control systems



**Control systems  
CMCA**

<b>Electrical connection</b>	Spring-loaded terminal
<b>Mains voltage AC</b>	230/400 V
<b>Nominal operating voltage phases</b>	3-phase
<b>Mains frequency</b>	50 ... 60 Hz
<b>Safety function</b>	Safe Stop 1 (SS1)
<b>Description</b>	<ul style="list-style-type: none"> <li>• Control solution for handling systems from Festo</li> <li>• Available on a mounting plate with or without control cabinet housing</li> <li>• Includes the multi-axis controller CMXR and the motor controller CMMP required for control</li> </ul>
<b>online: →</b>	<a href="#">cmca</a>

**Note:**  
Control cabinets for controllers in handling systems → 181

Software tool

**Vacuum selection**

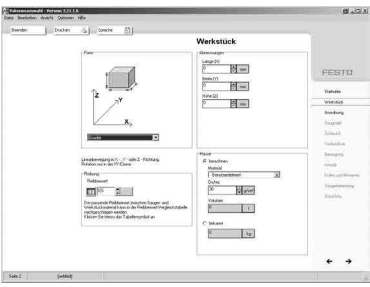





Which suction cup for which surface and which movement? Don't experiment – calculate! This software tool even enables a differentiation to be made between linear and rotary movements.



This tool can be found

- either in the electronic catalogue by clicking on the blue button “Engineering”
- or on the DVD under Engineering Tools



Vacuum generators

	 <div style="position: absolute; top: -20px; right: -20px; background-color: blue; color: white; padding: 2px 5px; transform: rotate(-45deg); font-weight: bold;">New</div> <p><b>Vacuum generators OVEM</b></p>	 <p><b>Vacuum generators, pneu- matic VN</b></p>	 <p><b>Vacuum generators VAD</b></p>	 <p><b>Vacuum generators VAK</b></p>
<b>Nominal width of Laval nozzle</b>	0.45 ... 2 mm	0.45 ... 3 mm	0.5 ... 1.5 mm	1 mm
<b>Ejector characteristics</b>	High suction rate, high vacuum, standard	High suction rate, high vacuum, standard, in-line, high vacuum, high suction rate	High vacuum	High vacuum
<b>Integrated function</b>	Electric ejector pulse valve, flow control valve, electric on-off valve, filter, electric air saving function, check valve, open silencer, vacuum switch	Pneumatic ejector pulse valve, open silencer, vacuum switch		Ejector pulse, pneumatic
<b>Max. vacuum</b>	93%	86 ... 93%	80%	80%
<b>Max. suction rate with respect to atmosphere</b>	6 ... 86.5 l/min	6.1 ... 339 l/min		
<b>New</b>	<ul style="list-style-type: none"> <li>• Straightforward operation and diagnostics: can be controlled easily from the PLC using IO-Link®</li> <li>• Variant with LCD display</li> </ul>			
<b>Description</b>	<ul style="list-style-type: none"> <li>• Compact design</li> <li>• Monitoring with vacuum sensor with IO-Link®</li> <li>• Central electrical connection via an M12 plug</li> <li>• Maintenance-free operation and reduced noise level through an integrated, open silencer</li> <li>• Integrated filter with inspection window</li> <li>• Optionally with air-saving function and LCD display</li> <li>• Adjustable ejector pulse</li> </ul>	<ul style="list-style-type: none"> <li>• Can be used directly in the work space</li> <li>• Available as a straight type (inline: vacuum port in line with the supply port) or T-shape (standard: vacuum port at 90° to the supply port)</li> <li>• Compact and cost-effective</li> <li>• Maintenance-free operation and reduced noise level through an integrated, open silencer</li> </ul>	<ul style="list-style-type: none"> <li>• Sturdy aluminium housing</li> </ul>	<ul style="list-style-type: none"> <li>• Sturdy aluminium housing</li> <li>• Ejector pulse through built-in reservoir</li> <li>• Connection for external reservoir</li> </ul>
<b>online:</b> →	<a href="#">ovem</a>	<a href="#">vn</a>	<a href="#">vad</a>	<a href="#">vak</a>

## Vacuum generators



	 <b>Vacuum generators, electropneumatic VN</b>	 <b>Vacuum generators VADM, VADMI</b>	 <b>Vacuum generators VAD-M, VAD-M-I</b>
<b>Nominal width of Laval nozzle</b>	0.45 ... 3 mm	0.45 ... 3 mm	0.7 ... 2 mm
<b>Ejector characteristics</b>	Standard, high vacuum, high suction rate	High vacuum	High vacuum
<b>Integrated function</b>	Pneumatic ejector pulse valve, electric on-off valve, open silencer	Electric ejector pulse valve, flow control valve, electric on-off valve, filter, electric air saving function, check valve, vacuum switch	Electric ejector pulse valve, electric on-off valve
<b>Max. vacuum</b>	92 ... 93%	85%	85 ... 90%
<b>Max. suction rate with respect to atmosphere</b>	7.2 ... 186 l/min		
<b>Description</b>	<ul style="list-style-type: none"> <li>• Can be used directly in the work space</li> <li>• Cost effective</li> <li>• Maintenance-free operation and reduced noise level through an integrated, open silencer</li> <li>• With solenoid valve vacuum On/Off</li> </ul>	<ul style="list-style-type: none"> <li>• Compact and sturdy design</li> <li>• Built-in solenoid valve (on/off)</li> <li>• Integrated filter with inspection window</li> <li>• Optionally with air-saving function, vacuum sensor</li> <li>• Optionally with adjustable ejector pulse</li> </ul>	<ul style="list-style-type: none"> <li>• Compact and sturdy design</li> <li>• Built-in solenoid valve (on/off)</li> <li>• Optionally with ejector pulse</li> </ul>
<b>online: →</b>	<a href="#">vn</a>	<a href="#">vadm</a>	<a href="#">vad-m</a>

## Vacuum generators

	 <b>Vacuum generators for valve terminals CPV CPV10-M1H, CPV14-M1H, CPV18-M1H</b>	 <b>Vacuum generator cartridges VN</b>
<b>Nominal width of Laval nozzle</b>	0.7 ... 1.4 mm	0.45 ... 2 mm
<b>Ejector characteristics</b>	High vacuum	Standard, high vacuum, high suction rate
<b>Integrated function</b>		
<b>Max. vacuum</b>	85%	92 ... 93%
<b>Max. suction rate with respect to atmosphere</b>		7.2 ... 184.4 l/min
<b>Description</b>	<ul style="list-style-type: none"> <li>• Combinations of switching valves with vacuum generators are possible on a valve terminal</li> <li>• With solenoid valve vacuum on/off</li> <li>• Optionally with ejector pulse</li> </ul>	<ul style="list-style-type: none"> <li>• For fitting into customised housing for decentralised vacuum generation</li> </ul>
<b>online: →</b>	<a href="#">cpv10-m1h</a>	<a href="#">vn</a>





Vacuum gripping technology

	 <b>Bernoulli gripper OGGB</b>	 <b>Suction gripper ESG</b>	 <b>Suction cups with connection attachments ESS</b>
<b>Suction cup size</b>		4x20 mm, 6x10 mm, 6x20 mm, 8x20 mm, 8x30 mm, 4x10 mm, 10x30 mm, 15x45 mm, 20x60 mm, 25x75 mm, 30x90 mm	4x20 mm, 6x10 mm, 6x20 mm, 8x20 mm, 8x30 mm, 4x10 mm, 10x30 mm, 15x45 mm, 20x60 mm, 25x75 mm, 30x90 mm
<b>Suction cup diameter</b>	60 mm, 100 mm, 140 mm	2 ... 200 mm	2 ... 200 mm
<b>Holding force at nominal operating pressure</b>	6 ... 10 N	0.1 ... 1610 N	0.1 ... 1610 N
<b>Design</b>		Vacuum port on top, vacuum port on the side, with height compensator, with long height compensator	Round, bell-shaped,
<b>Information on materials: suction cup</b>		BR, FPM, NBR, PUR, VMQ (silicone), Vulkollan®	BR, FPM, NBR, PUR, VMQ (silicone), Vulkollan®
<b>Description</b>	<ul style="list-style-type: none"> <li>• Ideally suited to transporting thin, extremely delicate and brittle workpieces</li> <li>• Minimised workpiece contact, gentle workpiece handling</li> <li>• Low energy costs thanks to minimised air consumption</li> </ul>	<ul style="list-style-type: none"> <li>• Modular system of suction cup holders and suction cups with over 2000 variants</li> <li>• Optionally with angle compensator, height compensator, filter</li> <li>• 15 suction cup diameters</li> <li>• 6 suction cup shapes</li> <li>• Suction cup volume: 0.002 ... 245 cm<sup>3</sup></li> <li>• Min. workpiece radius: 10 ... 680 mm</li> <li>• Vacuum port: push-in connector or barbed fitting for plastic tubing, threaded connection</li> </ul>	<ul style="list-style-type: none"> <li>• Suction cup consisting of the suction cup itself, plus the support plate with mounting</li> <li>• Suction cup volume: 0.002 ... 245 cm<sup>3</sup></li> <li>• Min. workpiece radius: 10 ... 680 mm</li> <li>• Mounting for suction cup holder: female thread, male thread, push-in connector</li> </ul>
<b>online: →</b>	<a href="#">oggb</a>	<a href="#">esg</a>	<a href="#">ess</a>

7

Vacuum gripping technology





	 <b>Suction cups ESV</b>	 <b>Suction cups with connection attachments VAS, VASB</b>
<b>Suction cup size</b>		
<b>Suction cup diameter</b>	20 ... 200 mm	2 ... 125 mm
<b>Holding force at nominal operating pressure</b>	8.2 ... 1610 N	0.14 ... 700 N
<b>Design</b>	Bell-shaped or round bellows	
<b>Information on materials: suction cup</b>	BR, FPM, NBR, PUR, VMQ (silicone), Vulkollan®	NBR, PUR, TPE-U (PU), VMQ (silicone)
<b>Description</b>	<ul style="list-style-type: none"> <li>• Wearing part for suction cup</li> <li>• Easily interchangeable</li> <li>• Suction cup volume: 0.318 ... 245 cm<sup>3</sup></li> <li>• Min. workpiece radius: 10 ... 680 mm</li> </ul>	<ul style="list-style-type: none"> <li>• Sturdy and reliable</li> <li>• Suction cups with fixed connecting thread</li> <li>• 11 suction cup diameters</li> <li>• Round suction cup shape, bellows</li> <li>• Vacuum port on top, on the side</li> <li>• Screw-in thread</li> </ul>
<b>online: →</b>	<a href="#">esv</a>	<a href="#">vas</a>





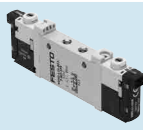

**Suction cup holders**  
**ESH**



<b>Design</b>	Vacuum port on top, vacuum port on the side, with height compensator
<b>Description</b>	<ul style="list-style-type: none"> <li>• With or without height compensator</li> <li>• 6 holder sizes</li> <li>• 8 holder types</li> <li>• 3 tubing connections</li> </ul>
<b>online:</b> →	<a href="#">esh</a>



## Universal directional control valves

	 <b>New</b> <b>Solenoid valves, for individual connection VUVG</b>	 <b>New</b> <b>Solenoid valves, plug-in VUVG</b>	 <b>Pneumatic valves VUWG</b>	 <b>New</b> <b>Solenoid valves VUVS</b>
<b>Type of control</b>	Electric	Electric	Pneumatic	Electric
<b>Pneumatic connection 1</b>	G1/4, G1/8, M3, M5, M7		G1/4, G1/8, M3, M5, M7	G1/4, G1/8, G3/8
<b>Pneumatic working port</b>	G1/4, G1/8, M3, M5, M7, QS-1/4, QS-1/8, QS-10, QS-3, QS-3/16, QS-3/8, QS-4, QS-5/16, QS-5/32, QS-6, QS-8, flange	G1/4, G1/8, M5, M7, flange	G1/4, G1/8, M3, M5, M7, QS-1/4, QS-1/8, QS-10, QS-3, QS-3/16, QS-3/8, QS-4, QS-5/16, QS-5/32, QS-6, QS-8	G1/4, G1/8, G3/8, NPT1/4-18, NPT1/8-27, NPT3/8-18, QS-1/2, QS-1/4, QS-10, QS-12, QS-3/8, QS-4, QS-5/16, QS-5/32, QS-6, QS-8
<b>Standard nominal flow rate</b>	80 ... 1380 l/min	130 ... 1200 l/min	80 ... 1380 l/min	550 ... 2400 l/min
<b>Valve function</b>	2x3/2-way, single solenoid, closed, 2x3/2-way, single solenoid, open, 2x3/2-way, single solenoid, open/closed, 5/2-way, double solenoid, 5/2-way, single solenoid, 5/3-way, pressurised, 5/3-way, exhausted, 5/3-way, closed	2x3/2-way, single solenoid, closed, 2x3/2-way, single solenoid, open, 2x3/2-way, single solenoid, open/closed, 3/2-way, single solenoid, closed, 3/2-way, single solenoid, open, 5/2-way, double solenoid, 5/2-way, single solenoid, 5/3-way, pressurised, 5/3-way, exhausted, 5/3-way, closed	2x3/2-way, monostable, closed, 2x3/2-way, monostable, open, 2x3/2-way, monostable, open/closed, 5/2-way, bistable, 5/2-way, monostable, 5/3-way, pressurised, 5/3-way, exhausted, 5/3-way, closed	3/2-way, single solenoid, closed, 3/2-way, single solenoid, open, 5/2-way, double solenoid, 5/2-way, single solenoid, 5/3-way, pressurised, 5/3-way, exhausted, 5/3-way, closed
<b>Electrical connection</b>	Plug, via E-box, connection pattern H, horizontal connection, M8x1 A-coded to EN 61076-2-104, 2-pin, 3-pin	Via E-box		To EN 175301-803, type B, type C
<b>New</b>	• Additional versions	• Additional versions		• Additional size
<b>Quick ordering of selected basic designs</b>	★			★
<b>Description</b>	<ul style="list-style-type: none"> <li>• Compact universal valve</li> <li>• Connection technology via E-box</li> <li>• High flow rate relative to its size</li> <li>• In-line valves can be used as individual valves or manifold valves</li> </ul>	<ul style="list-style-type: none"> <li>• Sub-base valve</li> <li>• For valve terminal VTUG with plug-in</li> </ul>	<ul style="list-style-type: none"> <li>• Compact universal valve</li> <li>• Pneumatically actuated</li> <li>• High flow rate relative to its size</li> <li>• In-line valves can be used as individual valves or manifold valves</li> </ul>	<ul style="list-style-type: none"> <li>• Universal valve, sturdy and durable</li> <li>• Low-cost, no performance limitations</li> <li>• Can be used as individual valves or manifold valves VTUS</li> </ul>
<b>online:</b> →	<a href="#">vuvg</a>	<a href="#">vuvg</a>	<a href="#">vuwg</a>	<a href="#">vuvs</a>





	 <b>Pneumatic valves</b> <b>VUWS</b>	 <b>Solenoid valves</b> <b>VMPA1, VMPA14, VMPA2</b>	 <b>Solenoid valves</b> <b>CPE10, CPE14, CPE18, CPE24</b>	 <b>Solenoid and pneumatic valves, Tiger 2000</b> <b>MFH, MVH, JMFH, JMVH, VL, J</b>
<b>Type of control</b>	Pneumatic	Electric	Electric, via pilot interface to ISO 15218	Electric, pneumatic
<b>Pneumatic connection 1</b>	G1/4, G1/8, G3/8	G1/8, M7	G1/4, G1/8, G3/8, M5, M7, QS-10, QS-12, QS-4, QS-6, QS-8	G1/4, G1/8, G3/8
<b>Pneumatic working port</b>	G1/4, G1/8, G3/8, NPT1/4-18, NPT1/8-27, NPT3/8-18, QS-1/4, QS-10, QS-3/8, QS-4, QS-5/16, QS-5/32, QS-6, QS-8	G1/8, M7	G1/4, G1/8, G3/8, M5, M7, QS-10, QS-12, QS-4, QS-6, QS-8	G1/4, G1/8, G3/8
<b>Standard nominal flow rate</b>	600 ... 2400 l/min	160 ... 900 l/min	180 ... 3200 l/min	750 ... 2600 l/min
<b>Valve function</b>	3/2-way, monostable, closed, 3/2-way, monostable, open, 5/2-way, bistable, 5/2-way, monostable, 5/3-way, pressurised, 5/3-way, exhausted, 5/3-way, closed	2x2/2-way, single solenoid, closed, 2x3/2-way, single solenoid, closed, 2x3/2-way, single solenoid, open, 2x3/2-way, single solenoid, open/closed, 3/2-way, single solenoid, closed, 3/2-way, single solenoid, open, 5/2-way, double solenoid, 5/2-way, single solenoid, 5/3-way, pressurised, 5/3-way, exhausted, 5/3-way, closed	3/2-way, single solenoid, closed, 3/2-way, single solenoid, open, 5/2-way, double solenoid, 5/2-way, single solenoid, 5/3-way, pressurised, 5/3-way, exhausted, 5/3-way, closed	5/2-way, bistable/double solenoid, 5/2-way, monostable/single solenoid, 5/3-way, pressurised, 5/3-way, exhausted, 5/3-way, closed
<b>Electrical connection</b>		M8x1, plug, to EN 60947-5-2, 4-pin	M8x1, Type C, 2-pin, 4-pin	Via F coil, to be ordered separately
<b>New</b>	• Additional size	• Additional versions		
<b>Description</b>	<ul style="list-style-type: none"> <li>• Universal valve, sturdy and durable</li> <li>• Pneumatically actuated</li> <li>• Can be used as individual valves or manifold valves VTUS</li> </ul>	<ul style="list-style-type: none"> <li>• For valve terminal MPA</li> <li>• As individual valve mounted on sub-base</li> <li>• Comprehensive valve range</li> </ul>	<ul style="list-style-type: none"> <li>• Universally applicable individual valve</li> <li>• High flow rate relative to its size</li> </ul>	<ul style="list-style-type: none"> <li>• Sturdy and reliable</li> <li>• Wide range of voltages due to individual coils</li> <li>• Principle with armature guide tube</li> </ul>
<b>online:</b> →	<a href="#">vuws</a>	<a href="#">vmpa1</a>	<a href="#">cpe</a>	<a href="#">tiger 2000</a>

## Universal directional control valves

	 <b>Solenoid and pneumatic valves, Tiger Classic</b> MFH, MOFH, JMFH, JMFHD, VL/O, VL, JH, JDH	 <b>Solenoid and pneumatic valves, midi pneumatic</b> MEBH, MOEBH, MEH, MOEH, JMEBH, JMEH, VL, J	 <b>Cassette valves</b> C, CJ, CJM, CL, CM
<b>Type of control</b>	Electric, pneumatic	Electric, pneumatic	Electric, pneumatic
<b>Pneumatic connection 1</b>	G1/2, G1/4, G1/8, G3/4, NPT1/8-27	G1/8, Sub-base	G1/2, G1/4, Sub-base
<b>Pneumatic working port</b>	G1/2, G1/4, G1/8, G3/4	G1/8, Sub-base	G1/2, G1/4, Sub-base
<b>Standard nominal flow rate</b>	500 ... 7500 l/min	300 ... 700 l/min	1400 l/min
<b>Valve function</b>	3/2-way, monostable/single solenoid, closed, 3/2-way, monostable/single solenoid, open, 3/2-way, monostable/single solenoid, open/closed, 5/2-way, bistable/double solenoid, 5/2-way, bistable/double solenoid, dominant signal, 5/2-way, monostable/single solenoid	3/2-way, monostable/single solenoid, closed, 3/2-way, monostable/single solenoid, open, 5/2-way, bistable/double solenoid, 5/2-way, monostable/single solenoid, 5/3-way, pressurised, 5/3-way, exhausted, 5/3-way, closed	5/2-way, double solenoid/bistable, 5/2-way, single solenoid/monostable
<b>Electrical connection</b>	Via F coil, to be ordered separately	Plug, square design, to EN 175301-803, type C, plug pattern type C to industry standard 9.4 mm	
<b>Description</b>	<ul style="list-style-type: none"> <li>• Sturdy and reliable</li> <li>• Poppet valve</li> <li>• All-metal version</li> <li>• Principle with armature guide tube</li> </ul>	<ul style="list-style-type: none"> <li>• Sub-base valve, semi in-line valve</li> <li>• Individual mounting or manifold assembly for 2 ... 10 valves</li> <li>• Operating voltage 24 V DC, 110/230 V AC (50 ... 60 Hz)</li> </ul>	<ul style="list-style-type: none"> <li>• Sturdy</li> <li>• Direct mounting on sub-base</li> <li>• With or without manual override</li> </ul>
<b>online:</b> →	<a href="#">tiger classic</a>	<a href="#">mebh</a>	<a href="#">cm</a>

	 <b>Solenoid valves, supplementary product range</b> <b>BMCH, BMFH, JMC, JMF, MC, MCH, MF, MFH, MLC, MOCH, MOFH</b>	 <b>Pneumatic valves, supplementary product range</b> <b>A, VL</b>	 <b>Basic valves</b> <b>LC</b>
<b>Type of control</b>	Electric		Pneumatic, electric
<b>Pneumatic connection 1</b>	G1/2, G1/4, G1/8, M5	G1/4	G1/8, G1/4
<b>Pneumatic working port</b>	G1/2, G1/4, G1/8, M5	G1/4	
<b>Standard nominal flow rate</b>	46 ... 300 l/min	700 l/min	80 ... 600 l/min
<b>Valve function</b>	2/2-way, single solenoid, closed, 2x3/2-way, single solenoid, closed, 3/2-way, single solenoid, closed, 3/2-way, single solenoid, open, 3x3/2-way, single solenoid, closed, 4/2-way, double solenoid, closed, 4/2-way, single solenoid, 5/4-way, closed	5/2-way, bistable, 5/4-way, closed	3/2-way, directly actuated, 5/4-way, indirectly actuated
<b>Electrical connection</b>	Plug connector		
<b>Description</b>	<ul style="list-style-type: none"> <li>• Manifold mounting or individual valve</li> <li>• Especially suited for positioning, for stopping in the event of an emergency stop and for holding double-acting cylinders in any position</li> <li>• With or without manual override</li> </ul>	<ul style="list-style-type: none"> <li>• For activating cylinders for single stroke and oscillating movements</li> <li>• For positioning, for stopping in the event of an emergency stop and for holding double-acting cylinders in any position</li> <li>• For controlling functions of pneumatic feed units such as feed motions and reciprocal clamping</li> <li>• Actuation either manually using a switch lever, mechanically using a control stem or pneumatically</li> </ul>	<ul style="list-style-type: none"> <li>• Screw-in actuator attachments</li> <li>• For positioning, for stopping in the event of an emergency stop and for holding double-acting cylinders in any position</li> </ul>
<b>online: →</b>	<a href="#">bmch</a>	<a href="#">vl</a>	<a href="#">lc</a>

## Standard directional control valves

	 <b>New</b> <b>Solenoid valves VSNC</b>	 <b>New</b> <b>Standards-based valves with central plug VSVA-R5, VSVA-R2</b>	 <b>New</b> <b>Standards-based valves with individual plug VSVA-C1, VSVA-P1</b>	 <b>New</b> <b>Standards-based valves, plug-in VSVA-T1</b>
<b>Type of control</b>	Electric	Electric	Electric	Electric
<b>Pneumatic connection 1</b>	G1/4, NPT1/4-18, QS-1/4, QS-10, QS-3/8, QS-5/16, QS-6, QS-8	Sub-base size 1 to ISO 5599-1, size 2 to ISO 5599-1	Sub-base size 18 to ISO 15407-1, size 26 to ISO 15407-1	Sub-base size 1 to ISO 5599-2, size 2 to ISO 5599-2, size 18 to ISO 15407-2, size 26 to ISO 15407-2
<b>Standard nominal flow rate</b>	800 ... 1350 l/min	400 ... 2800 l/min	400 ... 1400 l/min	370 ... 2900 l/min
<b>Valve function</b>	5/2-way, double solenoid, 5/2-way or 3/2-way, convertible, 5/3-way, pressurised, 5/3-way, exhausted, 5/3-way, closed	2x2/2-way, single solenoid, closed, 2x3/2-way, single solenoid, closed, 2x3/2-way, single solenoid, open, 2x3/2-way, single solenoid, open/closed, 5/2-way, double solenoid, 5/2-way, double solenoid, dominant signal, 5/2-way, single solenoid, 5/3-way, pressurised, 5/3-way, exhausted, 5/3-way, closed	2x2/2-way, single solenoid, closed, 2x3/2-way, single solenoid, closed, 2x3/2-way, single solenoid, open, 2x3/2-way, single solenoid, open/closed, 5/2-way, double solenoid, 5/2-way, double solenoid, dominant signal, 5/2-way, single solenoid, 5/3-way, pressurised, 5/3-way, exhausted, 5/3-way, closed	2x2/2-way, single solenoid, closed, 2x3/2-way, single solenoid, closed, 2x3/2-way, single solenoid, open, 2x3/2-way, single solenoid, open/closed, 5/2-way, double solenoid, 5/2-way, double solenoid, dominant signal, 5/2-way, single solenoid, 5/3-way, pressurised 1 to 2, 4 to 5 closed, 5/3-way, pressurised, 5/3-way, exhausted, 5/3-way, closed, 5/3-way, port 2 pressurised, 4 exhausted, 5/3-way, port 4 pressurised, 2 exhausted
<b>Electrical connection</b>	Plug, to EN 175301-803, to industry standard (11 mm), type A, type B, 3-pin	M8x1, M12x1, central plug, round design, 3-pin, 4-pin	To DIN EN 175301-803, type C, with protective earth conductor, without protective earth conductor	Plug, plug-in, to ISO 15407-2, to ISO 5599-2, 2-pin, 4-pin
<b>New</b>	• Additional versions	• Electrical timer function		• Option of manual override, non-detenting, heavy-duty • Electrical timer function
<b>Quick ordering of selected basic designs</b>	★	★	★	
<b>Description</b>	<ul style="list-style-type: none"> <li>• NAMUR interface</li> <li>• Rotatable seal for 3/2- or 5/2-way valve</li> <li>• Wide choice of EX solenoid systems</li> <li>• Sturdy and powerful</li> <li>• Extended temperature range</li> <li>• Outstanding value for money</li> </ul>	<ul style="list-style-type: none"> <li>• Corresponds to ISO 5599-1</li> <li>• Electrical connection via central plug</li> <li>• Robust metal housing</li> <li>• Manifold assembly with mixed sizes possible</li> </ul>	<ul style="list-style-type: none"> <li>• Corresponds to ISO 15407-1 and to ISO 15218 for pilot valve with interface</li> <li>• Electrical connection via type C plug</li> <li>• Robust metal housing</li> <li>• Manifold assembly with mixed sizes possible</li> </ul>	<ul style="list-style-type: none"> <li>• For valve terminal VTSA/VTSA-F</li> <li>• Robust metal housing</li> </ul>
<b>online:</b> →	<a href="#">vsnc</a>	<a href="#">vsva</a>	<a href="#">vsva</a>	<a href="#">vtsa</a>

## Standard directional control valves





	<b>Pneumatic valves, to ISO 15407-1 VSPA</b>	<b>Solenoid valves to ISO 5599-1 MN1H, MFH, MDH, MEBH, MDH, JMN1H, JMN1DH, JMFH, JMFDH, JMDH, JMEBH, JMEBDH, JMDDH</b>	<b>Pneumatic valves, to ISO 5599-1 VL, J, JD</b>
<b>Type of control</b>	Pneumatic	Electric	Pneumatic
<b>Pneumatic connection 1</b>	Sub-base size 18 to ISO 15407-1, size 26 to ISO 15407-1	Sub-base size 1 to ISO 5599-1, size 2 to ISO 5599-1, size 3 to ISO 5599-1, size 4 to ISO 5599-1	Sub-base size 1 to ISO 5599-1, size 2 to ISO 5599-1, size 3 to ISO 5599-1, size 4 to ISO 5599-1
<b>Standard nominal flow rate</b>	400 ... 1100 l/min	1200 ... 6000 l/min	1200 ... 6000 l/min
<b>Valve function</b>	2x3/2-way, monostable, closed, 2x3/2-way, monostable, open, 2x3/2-way, monostable, open/closed, 5/2-way, bistable, 5/2-way, bistable, dominant signal, 5/2-way, monostable, 5/3-way, pressurised, 5/3-way, exhausted, 5/3-way, closed	5/2-way, double solenoid, 5/2-way, double solenoid, dominant signal, 5/2-way, single solenoid, 5/3-way, pressurised, 5/3-way, exhausted, 5/3-way, closed	5/2-way, bistable, 5/2-way, bistable, dominant signal, 5/2-way, monostable, 5/3-way, pressurised, 5/3-way, exhausted, 5/3-way, closed
<b>Electrical connection</b>		M12x1, central plug, via F coil, to be ordered separately, via N1 coil, to be ordered separately, round design, to DIN EN 175301-803	
<b>Description</b>	<ul style="list-style-type: none"> <li>• Conforms to ISO 15407-1</li> <li>• Pneumatic actuation</li> <li>• Manifold assembly with mixed sizes possible</li> </ul>	<ul style="list-style-type: none"> <li>• Conforms to ISO 5599-1</li> <li>• Robust metal housing</li> <li>• Manifold assembly with a mixture of ISO sizes 1, 2 and 3 possible</li> <li>• Extensive range of electrical connection options</li> <li>• Wide range of vertical stacking modules: pressure regulator, flow control valve, vertical pressure shut-off plate, etc.</li> <li>• Also available as a valve terminal</li> </ul>	<ul style="list-style-type: none"> <li>• Conforms to ISO 5599-1</li> <li>• Pneumatic control</li> </ul>
<b>online: →</b>	<a href="#">vspa</a>	<a href="#">iso 5599-1</a>	<a href="#">iso 5599-1</a>

## Standard directional control valves



	<b>Standards-based valves, to ISO 15218 (CNOMO) MD, MDH, MGXDH, MGXIAH, VSCS</b>	<b>Standards-based valves, NAMUR (VDI/VDE 3845) NVF3</b>
<b>Type of control</b>	Electric	Electric
<b>Pneumatic connection 1</b>	Sub-base	G1/4
<b>Standard nominal flow rate</b>	18 ... 50 l/min	900 l/min
<b>Valve function</b>	2/2-way, single solenoid, closed	5/2-way or 3/2-way, single solenoid
<b>Electrical connection</b>	M12x1, to DIN EN 175301-803, to IEC 61076-2-101, type A, type C	Plug, 3-pin, or cable, 3-wire
<b>Description</b>	<ul style="list-style-type: none"> <li>• CNOMO port and connection pattern, to ISO 15218</li> <li>• With or without manual override</li> </ul>	<ul style="list-style-type: none"> <li>• NAMUR interface</li> <li>• Variants for use in Ex zone I</li> </ul>
<b>online: →</b>	<a href="#">iso 15218</a>	<a href="#">namur</a>





## Application-specific directional control valves

	 <b>Control blocks VOFA</b>	 <b>New</b> <b>Solenoid valves VOFD</b>	 <b>Solenoid valves VOFC</b>	 <b>Solenoid valves VOVG</b>
<b>Design</b>	Piston spool valve	Directly actuated poppet valve	Piston spool, piloted piston poppet valve	Piston spool valve
<b>Valve function</b>	3/2-way, monostable, closed, 5/2-way, monostable	3/2-way, closed, single solenoid, semi-automatic, 3/2-way, closed, single solenoid	3/2-way, single solenoid, closed, 5/2-way, double solenoid, 5/2-way, single solenoid	3/2-way, single-solenoid, closed, 3/2-way, single-solenoid, open, 5/2-way, single-solenoid
<b>Operating pressure</b>	3 ... 10 bar	0 ... 12 bar	0 ... 8 bar	-0.9 ... 8 bar
<b>Ambient temperature</b>	-5 ... 50 °C	-50 ... 60 °C	-25 ... 60 °C	-5 ... 50 °C
<b>Pneumatic connection 1</b>	G1/4	G1/4		M5, M7, Sub-base
<b>Standard nominal flow rate</b>	950 ... 1050 l/min	52 ... 1900 l/min	766 ... 2686 l/min	180 ... 200 l/min
<b>New</b>		<ul style="list-style-type: none"> <li>Additional versions</li> </ul>		
<b>Description</b>	<ul style="list-style-type: none"> <li>Redundantly constructed valve block, can be used for safe reversing of a hazardous movement</li> <li>Can be selected as a decentralised individual connection variant with electrical and pneumatic individual connection or as a feature integrated in the valve terminal VTSA/VTSA-F</li> <li>Equipped with VSVA valves</li> <li>Switching position sensing by sensors</li> </ul>	<ul style="list-style-type: none"> <li>Suitable for process automation, for applications in the chemical and petrochemical industries</li> <li>Suitable for outdoor use under harsh, dusty ambient conditions</li> <li>Especially suitable for quarter turn actuators thanks to NAMUR flange pattern</li> <li>Variants with TÜV approval up to SIL4 acc. to IEC 61508</li> </ul>	<ul style="list-style-type: none"> <li>Suitable for process automation, for applications in the chemical and petrochemical industries</li> <li>Suitable for outdoor use under harsh, dusty ambient conditions</li> <li>Especially suitable for quarter turn actuators thanks to NAMUR flange pattern</li> <li>Valve can switch between internal and external pilot air</li> <li>Variants with TÜV approval up to SIL3 acc. to IEC 61508</li> </ul>	<ul style="list-style-type: none"> <li>Very compact valve for solutions with extremely compact assembly</li> <li>Suitable for applications in the electronics and light assembly industry</li> <li>In-line, semi in-line and sub-base valve</li> <li>Manifold rail for 2 ... 10 valves</li> </ul>
<b>online:</b> →	<a href="#">vofa</a>	<a href="#">vofd</a>	<a href="#">vofc</a>	<a href="#">vofg</a>



## Application-specific directional control valves

	 <b>Solenoid valves</b> <b>MHA1, MHP1</b>	 <b>Solenoid valves</b> <b>MHE2, MHP2, MHA2, MHE3, MHP3, MHA3, MHE4, MHP4, MHA4</b>	 <b>Solenoid valves</b> <b>CDVI5.0</b>
<b>Design</b>	Poppet valve with spring return	Pressure-relieved poppet valve	Piston spool
<b>Valve function</b>	2/2-way, single solenoid, closed, 2x2/2-way, single solenoid, closed, 3/2-way, single solenoid, closed, 3/2-way, single solenoid, open	3/2-way, single-solenoid, closed, 3/2-way, single-solenoid, open, 5/2-way, single-solenoid	2/2-way, single solenoid, closed, 2/2-way, single solenoid, open, 2x3/2-way, single solenoid, closed, 2x3/2-way, single solenoid, open, 3/2-way, single solenoid, closed, 3/2-way, single solenoid, open, 5/2-way, double solenoid, 5/2-way, single solenoid, 5/3-way, pressurised, 5/3-way, exhausted, 5/3-way, closed
<b>Operating pressure</b>	-0.9 ... 8 bar	-0.9 ... 8 bar	-0.9 ... 10 bar
<b>Ambient temperature</b>	-5 ... 50 °C	-5 ... 60 °C	-5 ... 50 °C
<b>Pneumatic connection 1</b>	QS-3, QS-4, Sub-base, prepared for QSP10	G1/4, G1/8, M7, QS-4, QS-6, QS-8, Sub-base	Sub-base
<b>Standard nominal flow rate</b>	10 ... 30 l/min	90 ... 400 l/min	300 ... 650 l/min
<b>Description</b>	<ul style="list-style-type: none"> <li>• Directly actuated poppet valve</li> <li>• Miniature valve: grid dimension 10 mm</li> <li>• Switching times down to 4 ms</li> <li>• Sub-base valve</li> <li>• Manifold block for 2 ... 10 valves</li> </ul>	<ul style="list-style-type: none"> <li>• Directly actuated poppet valve</li> <li>• Fast-switching valve: switching times down to 2 ms</li> <li>• Direct mounting, individual sub-base, manifold assembly</li> <li>• Manifold block for 2 ... 10 valves</li> </ul>	<ul style="list-style-type: none"> <li>• Clean Design sub-base valve</li> <li>• Easy-to-clean design</li> </ul>
<b>online:</b> →	<a href="#">mh1</a>	<a href="#">mh2</a>	<a href="#">cdvi5.0</a>



## Application-specific directional control valves

	 <b>Fast-switching valves</b> <b>MHJ9, MHJ10</b>	 <b>Solenoid and pneumatic valves, M5 Compact System</b> <b>J, JD, JMFH, MFH, MUFH, VD, VL, VL/O, VLL</b>
<b>Design</b>	Poppet valve without spring return	Piston valve, disc seat valve
<b>Valve function</b>	2/2-way, monostable, closed	3/2-way, bistable/double solenoid, 3/2-way, monostable/single solenoid, closed, 3/2-way, monostable/single solenoid, open, 5/2-way, bistable/double solenoid, 5/2-way, bistable/double solenoid, dominant signal, 5/2-way, monostable/single solenoid
<b>Operating pressure</b>	0.5 ... 8 bar	-0.9 ... 8 bar
<b>Ambient temperature</b>	-5 ... 60 °C	-10 ... 60 °C
<b>Pneumatic connection 1</b>	QS-4, QS-6, Sub-base	PK-3
<b>Standard nominal flow rate</b>	50 ... 160 l/min	50 ... 105 l/min
<b>Description</b>	<ul style="list-style-type: none"> <li>• Directly actuated poppet valve</li> <li>• Individual valve with integrated QS fitting</li> <li>• Switching frequencies of up to 1000 Hz</li> <li>• Service life &gt; 500 million switching cycles</li> </ul>	<ul style="list-style-type: none"> <li>• Control elements with all functions for pneumatic sequence controls</li> <li>• For control cabinet installation</li> <li>• Fast replacement of components</li> </ul>
<b>online:</b> →	<a href="#">mhj9</a>	<a href="#">m5-compact</a>



## Manually actuated directional control valves: swivel lever valves

	 <b>Hand lever valves</b> <b>VHER</b>	 <b>Hand lever valves</b> <b>H-3-1/4-B, H-5-1/4-B</b>
<b>Valve function</b>	4/3-way, pressurised, 4/3-way, exhausted, 4/3-way, closed	3/2-way, bistable, 5/2-way, bistable
<b>Type of actuation</b>	Direct	Direct
<b>Standard nominal flow rate</b>	170 ... 3800 l/min	550 ... 600 l/min
<b>Pneumatic working port</b>	G1/2, G1/4, G1/8, M5	G1/4
<b>Operating pressure</b>	0 ... 10 bar	-0.95 ... 10 bar
<b>New</b>	<ul style="list-style-type: none"> <li>Additional versions</li> </ul>	
<b>Description</b>	<ul style="list-style-type: none"> <li>Lever in metal or polymer design</li> <li>Front panel mounting, through or mounting holes</li> </ul>	<ul style="list-style-type: none"> <li>Die-cast aluminium design</li> </ul>
<b>online: →</b>	<a href="#">vher</a>	<a href="#">n_v14</a>





## Manually actuated directional control valves: pushbutton valves

	 <b>Pushbutton valves</b> <b>VHEM-P</b>	 <b>Pushbutton valves</b> <b>K/O-3-PK</b>	 <b>Pushbutton valves</b> <b>K-3-M5</b>
<b>Valve function</b>	3/2-way, monostable, closed, 3/2-way, monostable, open, 5/2-way, bistable, 5/2-way, monostable	3/2-way, monostable, open/closed	3/2-way, monostable, closed
<b>Type of actuation</b>	Direct, piloted	Direct	Direct
<b>Standard nominal flow rate</b>	500 ... 1000 l/min	80 l/min	80 l/min
<b>Pneumatic working port</b>	G1/4, G1/8	PK-3	M5
<b>Operating pressure</b>	-0.95 ... 10 bar	0 ... 8 bar	-0.95 ... 8 bar
<b>Description</b>	<ul style="list-style-type: none"> <li>With button switch</li> <li>Reverse operation possible</li> </ul>	<ul style="list-style-type: none"> <li>With button switch</li> <li>Polymer design</li> <li>Ducted exhaust air</li> </ul>	<ul style="list-style-type: none"> <li>With button switch</li> <li>Suitable for vacuum operation</li> <li>Sturdy die-cast zinc design</li> </ul>
<b>online: →</b>	<a href="#">vhem-p</a>	<a href="#">n_vpk</a>	<a href="#">k-3</a>

## Manually actuated directional control valves: pushbutton valves



	 <b>Pushbutton valves</b> <b>T-5/3-1/4</b>	 <b>Pushbutton valves</b> <b>F-3-M5</b>
<b>Valve function</b>	5/3-way, closed	2/2-way, monostable, closed
<b>Type of actuation</b>	Piloted	Direct
<b>Standard nominal flow rate</b>	680 l/min	80 l/min
<b>Pneumatic working port</b>	G1/4	M5
<b>Operating pressure</b>	2 ... 10 bar	-0.9 ... 8 bar
<b>Description</b>	<ul style="list-style-type: none"> <li>With pushbutton</li> <li>For positioning, for stopping in the event of an emergency stop and for holding double-acting cylinders in any position</li> <li>Aluminium design</li> </ul>	<ul style="list-style-type: none"> <li>With pedal</li> <li>Suitable for vacuum operation</li> <li>Sturdy die-cast zinc design</li> </ul>
<b>online: →</b>	<a href="#">n_msv</a>	<a href="#">f-3-m5</a>

## Manually actuated directional control valves: finger lever valves



	 <b>Finger lever valves</b> <b>VHEM-L</b>	 <b>Finger lever valves</b> <b>TH/O-3-PK-3</b>	 <b>Finger lever valves</b> <b>THO-3-1/4-B</b>	 <b>Finger lever valves</b> <b>H-4/3-M5</b>
<b>Valve function</b>	3/2-way, monostable, closed, 3/2-way, monostable, open, 5/2-way, monostable	3/2-way, monostable, open/ closed,	3/2-way, monostable, closed, 3/2-way, monostable, open, 5/2-way, monostable	4/3-way, exhausted
<b>Type of actuation</b>	Direct	Direct	Direct	Piloted
<b>Standard nominal flow rate</b>	500 ... 1000 l/min	80 l/min	80 ... 600 l/min	125 l/min
<b>Pneumatic working port</b>	G1/4, G1/8	PK-3	G1/4, M5	M5
<b>Operating pressure</b>	-0.95 ... 10 bar	0 ... 8 bar	-0.95 ... 10 bar	0 ... 8 bar
<b>Description</b>	<ul style="list-style-type: none"> <li>• With finger lever</li> <li>• Mechanical spring return</li> <li>• Quick mounting</li> </ul>	<ul style="list-style-type: none"> <li>• With finger lever</li> <li>• Polymer design</li> <li>• Ducted exhaust air</li> </ul>	<ul style="list-style-type: none"> <li>• With finger lever</li> <li>• Die-cast zinc or die-cast aluminium design</li> </ul>	<ul style="list-style-type: none"> <li>• With detenting finger lever</li> <li>• Front panel mounting or mounting on sub-base</li> <li>• Aluminium design</li> </ul>
<b>online: →</b>	<a href="#">vhem-l</a>	<a href="#">n_vpk</a>	<a href="#">th-3-m5</a>	<a href="#">h-4</a>

8

## Manually actuated directional control valves: toggle lever valves

	 <b>Toggle lever valves</b> <b>KH/O-3-PK-3</b>	 <b>Toggle lever valves</b> <b>H-5/3-1/4</b>
<b>Valve function</b>	3/2-way, monostable, open/closed	5/3-way, closed
<b>Type of actuation</b>	Direct	Piloted
<b>Standard nominal flow rate</b>	80 l/min	680 l/min
<b>Pneumatic working port</b>	PK-3	G1/4
<b>Operating pressure</b>	0 ... 8 bar	2 ... 10 bar
<b>Description</b>	<ul style="list-style-type: none"> <li>• With toggle lever</li> <li>• Polymer design</li> <li>• Ducted exhaust air</li> </ul>	<ul style="list-style-type: none"> <li>• With toggle lever</li> <li>• For positioning, for stopping in the event of an emergency stop and for holding double-acting cylinders in any position</li> <li>• Aluminium design</li> </ul>
<b>online: →</b>	<a href="#">n_vpk</a>	<a href="#">n_msv</a>



## Manually actuated directional control valves: foot valves

	 <b>Foot valves</b> <b>F-3-1/4-B, FO-3-1/4-B, F-5-1/4-B</b>	 <b>Foot valves with detent</b> <b>FP-3-1/4-B, FPB-3-1/4, FP-5-1/4-B</b>
<b>Valve function</b>	3/2-way, monostable, closed, 3/2-way, monostable, open, 5/2-way, monostable	3/2-way, bistable, 5/2-way, bistable
<b>Type of actuation</b>	Direct	Direct
<b>Standard nominal flow rate</b>	550 ... 600 l/min	550 ... 600 l/min
<b>Pneumatic working port</b>	G1/4	G1/4
<b>Operating pressure</b>	-0.95 ... 10 bar	-0.95 ... 10 bar
<b>Description</b>	<ul style="list-style-type: none"> <li>• With foot pedal</li> <li>• Sturdy die-cast zinc design</li> </ul>	<ul style="list-style-type: none"> <li>• With foot pedal with detent</li> <li>• Sturdy die-cast zinc design</li> </ul>
<b>online: →</b>	<a href="#">fo-3</a>	<a href="#">fpb-3</a>

## Manually operated directional control valves: selector switches





	 <b>Selector switch</b> <b>HW-6-38</b>
<b>Valve function</b>	8/6-way, monostable
<b>Type of actuation</b>	Direct
<b>Standard nominal flow rate</b>	180 l/min
<b>Pneumatic working port</b>	M5
<b>Operating pressure</b>	0 ... 8 bar
<b>Description</b>	<ul style="list-style-type: none"> <li>• With rotary knob and arrow</li> <li>• Front panel mounting or mounting on sub-base</li> <li>• With six switching positions</li> </ul>
<b>online: →</b>	<a href="#">hw-6</a>

## Manually operated directional control valves: front panel valves



	 <b>Front panel valves</b> <b>SV/O-3-PK-3x2</b>	 <b>Front panel valves</b> <b>SVS-3-1/8, SVS-4-1/8, SVSO-3-1/8</b>	 <b>Front panel valves</b> <b>SV-3-M5, SV-5-M5-B</b>
<b>Valve function</b>	2x3/2-way, monostable, closed	3/2-way, monostable, closed, 3/2-way, monostable, open, 4/2-way, monostable	3/2-way, monostable, closed, 5/2-way, monostable
<b>Type of actuation</b>	Direct	Direct, piloted	Direct
<b>Standard nominal flow rate</b>	70 l/min	120 l/min	65 ... 95 l/min
<b>Pneumatic working port</b>	PK-3	G1/8	M5
<b>Operating pressure</b>	0 ... 8 bar	3.5 ... 8 bar	-0.95 ... 8 bar
<b>Description</b>	<ul style="list-style-type: none"> <li>• For actuator attachments such as toggle and selector switches</li> <li>• Reliable coupling system for rapid mounting and dismounting</li> <li>• Polymer design</li> </ul>	<ul style="list-style-type: none"> <li>• For actuator attachments such as pushbutton actuators, mushroom pushbuttons, mushroom actuators, selector switches, toggle levers, key actuators</li> <li>• Reliable coupling system for quick mounting and dismounting</li> </ul>	<ul style="list-style-type: none"> <li>• For actuator attachments such as pushbutton actuators, mushroom pushbuttons, mushroom pushbuttons with detent, selector switches or toggle levers</li> <li>• Reliable coupling system for quick mounting and dismounting</li> <li>• Polymer design</li> </ul>
<b>online: →</b>	<a href="#">sv</a>	<a href="#">svos</a>	<a href="#">sv-3</a>

8

## Mechanically operated directional control valves: stem actuated valves



	 <b>Stem actuated valves</b> <b>VMEM-S</b>	 <b>Stem actuated valves</b> <b>V/O-3-PK-3, V/O-3-1/8</b>	 <b>Stem actuated micro valves</b> <b>S-3-PK-3-B, SO-3-PK-3-B</b>	 <b>Stem actuated valves</b> <b>VS-3-1/8, VS-4-1/8, VOS-3-1/8</b>
<b>Valve function</b>	3/2-way, monostable, closed, 3/2-way, monostable, open, 5/2-way, monostable	3/2-way, monostable, open/closed,	3/2-way, monostable, closed, 3/2-way, monostable, open	3/2-way, monostable, closed, 3/2-way, monostable, open, 4/2-way, monostable
<b>Type of actuation</b>	Direct, piloted	Direct	Direct	Piloted
<b>Standard nominal flow rate</b>	500 ... 1000 l/min	80 ... 140 l/min	60 l/min	140 ... 161 l/min
<b>Pneumatic working port</b>	G1/4, G1/8	PK-3, G1/8	PK-3	G1/8
<b>Operating pressure</b>	-0.95 ... 10 bar	-0.95 ... 8 bar	-0.95 ... 8 bar	3.5 ... 8 bar
<b>Description</b>	<ul style="list-style-type: none"> <li>• Light weight</li> <li>• Small size</li> <li>• Various actuator attachments</li> </ul>	<ul style="list-style-type: none"> <li>• Through-holes in housing</li> <li>• Polymer or aluminium design</li> </ul>	<ul style="list-style-type: none"> <li>• Dimensions to DIN 41635, type A</li> <li>• Polymer design</li> <li>• Various actuator attachments</li> </ul>	<ul style="list-style-type: none"> <li>• Aluminium design</li> <li>• Minimal actuating force with pilot control</li> </ul>
<b>online: →</b>	<a href="#">vmem</a>	<a href="#">n_v18</a>	<a href="#">s-3-pk</a>	<a href="#">vos</a>

## Mechanically operated directional control valves: stem actuated valves



	 <b>Stem actuated valves</b> V-3-1/4-B, V-5-1/4-B, VO-3-1/4-B	 <b>Limit switches with push-in connector</b> SDK	 <b>Limit stop signal generators with push-in connector</b> SDV
<b>Valve function</b>	3/2-way, monostable, closed, 3/2-way, monostable, open, 5/2-way, monostable	3/2-way, monostable, closed	3/2-way, monostable, closed
<b>Type of actuation</b>	Direct	Direct	Direct
<b>Standard nominal flow rate</b>	550 ... 600 l/min	16 l/min	8 ... 16 l/min
<b>Pneumatic working port</b>	G1/4	PK-3	PK-3
<b>Operating pressure</b>	-0.95 ... 10 bar	0 ... 8 bar	0 ... 8 bar
<b>Description</b>	<ul style="list-style-type: none"> <li>Die-cast aluminium design</li> </ul>	<ul style="list-style-type: none"> <li>For end-position sensing and position control</li> <li>High accuracy</li> <li>Stainless steel design</li> </ul>	<ul style="list-style-type: none"> <li>For end-position sensing and position control</li> <li>High precision and low actuating forces</li> <li>Sturdy design</li> </ul>
<b>online:</b> →	<a href="#">vo-3</a>	<a href="#">sdk</a>	<a href="#">sdv</a>

8

## Mechanically operated directional control valves: roller lever valves



	 <b>Roller lever valves</b> R/O-3-PK-3	 <b>Roller lever valves</b> RS-3-1/8, RS-4-1/8, ROS-3-1/8	 <b>Roller lever valves</b> R-3-M5, R-3-1/4-B, R-5-1/4-B, RO-3-1/4-B
<b>Valve function</b>	3/2-way, monostable, open/closed	3/2-way, monostable, closed, 3/2-way, monostable, open, 4/2-way, monostable	3/2-way, monostable, closed, 3/2-way, monostable, open, 5/2-way, monostable
<b>Type of actuation</b>	Direct	Piloted	Direct
<b>Standard nominal flow rate</b>	80 l/min	128 ... 169 l/min	80 ... 600 l/min
<b>Pneumatic working port</b>	PK-3	G1/8	G1/4, M5
<b>Operating pressure</b>	0 ... 8 bar	3.5 ... 8 bar	-0.95 ... 10 bar
<b>Description</b>	<ul style="list-style-type: none"> <li>With roller lever</li> <li>Polymer design</li> <li>Ducted exhaust air</li> </ul>	<ul style="list-style-type: none"> <li>With roller lever</li> <li>Aluminium design</li> <li>Minimal actuating force with pilot control</li> </ul>	<ul style="list-style-type: none"> <li>With roller lever</li> <li>Die-cast aluminium design</li> </ul>
<b>online:</b> →	<a href="#">n_vpk</a>	<a href="#">ros-3</a>	<a href="#">ro-3</a>

## Mechanically operated directional control valves: roller lever valves with idle return

	 <b>Toggle lever valves</b> L/O-3-PK-3	 <b>Roller lever valves with idle return</b> LS-3-1/8, LS-4-1/8, LOS-3-1/8	 <b>Roller lever valves with idle return</b> L-3-M5, L-3-1/4-B, L-4-1/4-B, LO-3-1/4-B
<b>Valve function</b>	3/2-way, monostable, open/closed	3/2-way, monostable, closed, 3/2-way, monostable, open, 4/2-way, monostable	3/2-way, monostable, closed, 3/2-way, monostable, open, 5/2-way, monostable
<b>Type of actuation</b>	Direct	Piloted	Direct
<b>Standard nominal flow rate</b>	80 l/min	128 ... 175 l/min	80 ... 600 l/min
<b>Pneumatic working port</b>	PK-3	G1/8	G1/4, M5
<b>Operating pressure</b>	0 ... 8 bar	3.5 ... 8 bar	-0.95 ... 10 bar
<b>Description</b>	<ul style="list-style-type: none"> <li>• With roller lever with idle return</li> <li>• Polymer design</li> <li>• Ducted exhaust air</li> </ul>	<ul style="list-style-type: none"> <li>• With toggle lever</li> <li>• Aluminium design</li> <li>• Minimal actuating force with pilot control</li> </ul>	<ul style="list-style-type: none"> <li>• With roller lever</li> <li>• Die-cast aluminium design</li> </ul>
<b>online: →</b>	<a href="#">n_vpk</a>	<a href="#">los-3</a>	<a href="#">lo-3</a>

8

## Mechanically operated directional control valves: swivel lever valves

	 <b>Swivel lever valves</b> RW/O-3-1/8	 <b>Pneumatic limit valves</b> RWN/O-3-1/8-B	 <b>Swivel lever valves</b> RW-3-M5
<b>Valve function</b>	3/2-way, monostable, open/closed	3/2-way, monostable, open/closed	3/2-way, monostable, closed
<b>Type of actuation</b>	Direct	Direct	Direct
<b>Standard nominal flow rate</b>	140 l/min	120 l/min	80 l/min
<b>Pneumatic working port</b>	G1/8	G1/8	M5
<b>Operating pressure</b>	-0.95 ... 8 bar	-0.95 ... 8 bar	-0.95 ... 8 bar
<b>Description</b>	<ul style="list-style-type: none"> <li>• Basic valve for actuator attachments such as swivel lever short, long, swivel lever rod</li> <li>• Aluminium design</li> </ul>	<ul style="list-style-type: none"> <li>• Directly actuated in one direction</li> <li>• Aluminium design</li> </ul>	<ul style="list-style-type: none"> <li>• With swivel lever</li> <li>• Sturdy die-cast zinc design</li> <li>• Various actuator attachments</li> </ul>
<b>online: →</b>	<a href="#">rw</a>	<a href="#">rwn</a>	<a href="#">rw-3</a>





## Mechanically operated directional control valves: whisker valves



	 <p><b>Whisker valves</b> <b>FVS-3-1/8, FVSO-3-1/8</b></p>
<b>Valve function</b>	3/2-way, monostable, closed, 3/2-way, monostable, open
<b>Type of actuation</b>	Piloted
<b>Standard nominal flow rate</b>	146 ... 175 l/min
<b>Pneumatic working port</b>	G1/8
<b>Operating pressure</b>	3.5 ... 8 bar
<b>Description</b>	<ul style="list-style-type: none"> <li>• With whisker</li> <li>• For sensing dissimilar workpieces or workpieces not precisely in position</li> <li>• Aluminium design</li> <li>• Minimal actuating force with pilot control</li> </ul>
<b>online: →</b>	<a href="#">fvs-3</a>

## Check valves and quick exhaust valves

8



	 <p><b>Check valves, piloted</b> <b>VBNF</b></p>	 <p><b>Quick exhaust valves</b> <b>VBQF</b></p>	 <p><b>Check valves</b> <b>H, HA, HB</b></p>
<b>Pneumatic connection 1</b>	QS-6, QS-8	G1/4, G1/8, QS-6, QS-8	G1/2, G1/4, G1/8, G3/4, G3/8, M5, QS-10, QS-12, QS-4, QS-6, QS-8, R1/2, R1/4, R1/8, R3/8
<b>Standard nominal flow rate</b>			115 ... 2230 l/min
<b>Standard flow rate exhaust 6→0 bar</b>		850 ... 2500 l/min	
<b>Standard nominal flow rate pressurisation 6→5 bar</b>		350 ... 960 l/min	
<b>Standard nominal flow rate 1 → 2 from 6 to 5 bar</b>	260 ... 620 l/min		1000 ... 5900 l/min
<b>Operating pressure</b>		0.2 ... 10 bar	-1 ... 12 bar
<b>Operating pressure for entire temperature range</b>	0.2 ... 10 bar		
<b>Description</b>	<ul style="list-style-type: none"> <li>• Minimal height</li> <li>• High flow rate</li> <li>• Can be rotated horizontally through 360° when mounted</li> </ul>	<ul style="list-style-type: none"> <li>• Minimal height</li> <li>• High flow rate</li> <li>• Reduced noise emission</li> <li>• Available with silencer</li> <li>• Available with ducted or unducted exhaust air</li> </ul>	<ul style="list-style-type: none"> <li>• Valve function: non-return</li> <li>• Screw-in or in-line installation</li> <li>• With connecting thread at both ends, push-in connector at both ends, thread/push-in connector</li> </ul>
<b>online: →</b>	<a href="#">vbnf</a>	<a href="#">vbqf</a>	<a href="#">h-qs</a>

## Check valves and quick exhaust valves





	 <b>Check valves, piloted HGL</b>	 <b>Manual override HAB</b>	 <b>Quick exhaust valves SE, SEU</b>
<b>Pneumatic connection 1</b>	G1/2, G1/4, G1/8, G3/8, M5, QS-10, QS-12, QS-4, QS-6, QS-8	G1/2, G1/4, G1/8, G3/8	G1/2, G1/4, G1/8, G3/4, G3/8
<b>Standard nominal flow rate</b>			
<b>Standard flow rate exhaust 6-&gt;0 bar</b>		165 l/min	550 ... 7500 l/min
<b>Standard nominal flow rate pressurisation 6-&gt;5 bar</b>			300 ... 4560 l/min
<b>Standard nominal flow rate 1 -&gt; 2 from 6 to 5 bar</b>	130 ... 1600 l/min		
<b>Operating pressure</b>	0.5 ... 10 bar	0 ... 10 bar	0.2 ... 10 bar
<b>Operating pressure for entire temperature range</b>			
<b>Quick ordering of selected basic designs</b>	★		
<b>Description</b>	<ul style="list-style-type: none"> <li>• Valve function: piloted non-return function</li> <li>• Pneumatically piloted</li> <li>• Screw-in with male thread</li> <li>• Pilot air connection: M5, G1/8, G1/4, G3/8, QS-4</li> </ul>	<ul style="list-style-type: none"> <li>• Valve function: exhaust component</li> <li>• For check valve HGL</li> <li>• For manually exhausting air trapped in a cylinder</li> </ul>	<ul style="list-style-type: none"> <li>• Valve function: quick exhaust</li> <li>• Shut-off valve, piloted</li> <li>• Screw-in</li> <li>• With or without silencer</li> </ul>
<b>online: →</b>	<a href="#">hgl</a>	<a href="#">hab</a>	<a href="#">se</a>

8



## Ball valves and on-off valves

	 <b>Hand slide valves VBOH</b>	 <b>On-off valves HE</b>	 <b>Ball valves QH, QHS</b>
<b>Valve function</b>	3/2-way, monostable	2/2-way bistable, 3/2-way bistable	2/2-way, bistable
<b>Pneumatic connection 1</b>	G1/2, G1/4, G1/8, G3/4, G3/8, M5	QS-10, QS-12, QS-6, QS-8, R1/2, R1/4, R1/8, R3/8	G1, G1 1/2, G1/2, G1/4, G3/4, G3/8, QS-4, QS-6, R1/8
<b>Standard nominal flow rate</b>	236 ... 7691 l/min	270 ... 840 l/min	148 ... 84000 l/min
<b>Operating pressure</b>	-0.95 ... 12 bar	-0.95 ... 10 bar	-1 ... 10 bar
<b>New</b>	<ul style="list-style-type: none"> <li>• Additional versions</li> </ul>		
<b>Description</b>	<ul style="list-style-type: none"> <li>• Used as a shut-off function for pressurising and exhausting compressed air systems, for example, upstream of service unit combinations, for air guns and also for exhausting pneumatic cylinders</li> <li>• Non-overlapping, so no pressure losses when switching</li> <li>• Minimal installation</li> </ul>	<ul style="list-style-type: none"> <li>• Shut-off valve, manually actuated</li> <li>• Connection: thread at both ends, push-in connector at both ends, thread/push-in connector</li> </ul>	<ul style="list-style-type: none"> <li>• Shut-off valve, manually actuated</li> <li>• In-line installation, can be screwed in, bulkhead fitting</li> <li>• Variants: thread at both ends, push-in connector at both ends, threaded/push-in connector</li> </ul>
<b>online: →</b>	<a href="#">vboh</a>	<a href="#">he</a>	<a href="#">qh</a>





## Logic valves

	 <b>OR gates OS</b>	 <b>Amplifier modules VK</b>	 <b>NOT modules VLO</b>	 <b>AND gates ZK</b>
<b>Valve function</b>	OR function			AND function
<b>Pneumatic connection 1</b>	G1/2, G1/4, G1/8, PK-3, PK-4	M5	M5	G1/8, PK-3, PK-4
<b>Standard nominal flow rate</b>	100 ... 5000 l/min	80 l/min	80 l/min	100 ... 550 l/min
<b>Operating pressure</b>	0.001 ... 10 bar	0.001 ... 6 bar	0.001 ... 6 bar	0.001 ... 10 bar
<b>Description</b>	<ul style="list-style-type: none"> <li>• Pneumatic control system</li> <li>• Mounting via through-holes</li> </ul>	<ul style="list-style-type: none"> <li>• For pneumatic sensors</li> </ul>	<ul style="list-style-type: none"> <li>• For pneumatic sensors</li> </ul>	<ul style="list-style-type: none"> <li>• Dual-pressure valve</li> <li>• Connects two input signals in the AND function</li> <li>• Mounting via through-holes</li> </ul>
<b>online:</b> →	<a href="#">os</a>	<a href="#">vk</a>	<a href="#">vlo</a>	<a href="#">zk</a>

## Pressure regulators



	 <b>Pressure regulators LR, LRMA</b>	 <b>Differential pressure regulators LRL, LRLl</b>
<b>Pressure regulation range</b>	1 ... 8 bar	2 ... 6 bar
<b>Standard nominal flow rate</b>	22 ... 150 l/min	
<b>Nominal flow rate, closed</b>		30 ... 730 l/min
<b>Nominal flow rate, open</b>		30 ... 760 l/min
<b>Pneumatic connection 1</b>	G1/4, G1/8, M5, QS-4, QS-6, QS-8	G1/2, G1/4, G1/8, G3/8, M5
<b>Pneumatic connection 2</b>	QS-4, QS-6, QS-8	QS-10, QS-12, QS-4, QS-6, QS-8
<b>Description</b>	<ul style="list-style-type: none"> <li>• Piston regulator with through pressure supply</li> <li>• Optionally with pressure gauge</li> <li>• Directly actuated</li> <li>• Connections: push-in connector at both ends, thread/push-in connector</li> <li>• Push-in connector, can be rotated 360°</li> </ul>	<ul style="list-style-type: none"> <li>• Piston regulator with through pressure supply</li> <li>• Without pressure gauge</li> <li>• Connections: thread/push-in connector on top or at the side</li> <li>• Push-in connector, can be rotated 360°</li> </ul>
<b>online:</b> →	<a href="#">lrma</a>	<a href="#">lrl</a>

## One-way flow control valves



	 <b>One-way flow control valves VFOH</b>	 <b>One-way flow control valves VFOF</b>	 <b>One-way flow control valves VFOC</b>	 <b>One-way flow control valves GRLA, GRLZ, CRGRLA, GRGA, GRGZ, GRLSA</b>
<b>Valve function</b>	Exhaust air one-way flow control function	Exhaust air one-way flow control function	Supply air one-way flow control function	Exhaust air one-way flow control function, one-way flow control function, supply air one-way flow control function
<b>Pneumatic connection 1</b>	QS-10, QS-4, QS-6, QS-8	QS-6, QS-8	QS-4, QS-6	G1/2, G1/4, G1/8, G3/4, G3/8, M3, M5, PK-3, PK-3 with union nut, PK-4, PK-4 with union nut, PK-6 with union nut, QS-10, QS-12, QS-3, QS-4, QS-6, QS-8
<b>Standard nominal flow rate in flow control direction</b>	180 ... 530 l/min	240 ... 650 l/min	0 ... 270 l/min	0 ... 4320 l/min
<b>Adjusting element</b>	External hex	Internal hex	Slotted head screw	Knurled screw, slotted head screw, internal hex
<b>Quick ordering of selected basic designs</b>				★
<b>Description</b>	<ul style="list-style-type: none"> <li>• Easy-to-clean design</li> <li>• Increased corrosion protection</li> <li>• Can be rotated horizontally through 360° when mounted</li> </ul>	<ul style="list-style-type: none"> <li>• Minimal height</li> <li>• High flow rate</li> <li>• Can be rotated horizontally through 360° when mounted</li> <li>• Functional combination of one-way flow control valve and piloted non-return valve</li> </ul>	<ul style="list-style-type: none"> <li>• Shut-off valve, flow control at one end</li> <li>• Metal design</li> <li>• Precision adjustment for low and medium speeds</li> <li>• Push-in connector/push-in sleeve</li> </ul>	<ul style="list-style-type: none"> <li>• Flow control valve, flow control at one end</li> <li>• Polymer, metal or stainless steel design</li> <li>• Standard, mini, in-line variants with different flow rates</li> <li>• Functional combination of one-way flow control valve and piloted non-return valve</li> <li>• Connections: thread at both ends, push-in connector at both ends, threaded/push-in connector</li> </ul>
<b>online:</b> →	<a href="#">vfoh</a>	<a href="#">vfof</a>	<a href="#">vfoc</a>	<a href="#">grla</a>

8

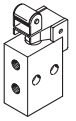

## One-way flow control valves

	 <b>One-way flow control valves GRXA</b>	 <b>One-way flow control valves GR, GRA</b>	 <b>One-way flow control valves GG, GGO, GRR</b>
<b>Valve function</b>	Exhaust air one-way flow control function	One-way flow control function	One-way flow control function
<b>Pneumatic connection 1</b>	QS-4, QS-6, QS-8	G1/2, G1/4, G1/8, G3/4, G3/8, M3, M5, QS-3, QS-4, QS-6, QS-8	G1/2, G1/4
<b>Standard nominal flow rate in flow control direction</b>	130 ... 280 l/min	29.5 ... 3300 l/min	870 ... 1300 l/min
<b>Adjusting element</b>	Slotted head screw	Knurled screw	Roller lever
<b>Description</b>	<ul style="list-style-type: none"> <li>• Functional combination of one-way flow control valve and piloted check valve</li> <li>• Holding function and speed adjustment in one housing</li> <li>• Additional supply port for holding crossover connection</li> </ul>	<ul style="list-style-type: none"> <li>• Non-return and flow control valve</li> <li>• In-line installation</li> </ul>	<ul style="list-style-type: none"> <li>• Non-return and flow control valve</li> <li>• With roller lever</li> </ul>
<b>online:</b> →	<a href="#">grxa-hg</a>	<a href="#">gra</a>	<a href="#">gg</a>



## One-way flow control valves

		
	<b>Precision one-way flow control valves GRP</b>	<b>One-way flow control valves, M5 Compact System GRF</b>
<b>Valve function</b>	One-way flow control function	One-way flow control function
<b>Pneumatic connection 1</b>	G1/8, PK-3, PK-4	PK-3
<b>Standard nominal flow rate in flow control direction</b>	3.8 ... 75.8 l/min	45 l/min
<b>Adjusting element</b>	Rotary knob with scale	Knurled screw
<b>Description</b>	<ul style="list-style-type: none"> <li>• Non-return and flow control valve</li> <li>• Mounting on sub-base or for front panel mounting</li> </ul>	<ul style="list-style-type: none"> <li>• Complete system offering control components with all the functions required for pneumatic sequence controls</li> <li>• For control cabinet installation</li> <li>• Fast replacement of components</li> </ul>
<b>online:</b> →	<a href="#">grp</a>	<a href="#">m5-compact</a>

## Flow control valves

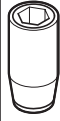

			
	<b>Flow control silencers VFFK</b>	<b>Flow control valves GRLO, GRGO</b>	<b>Flow control valves, barbed Y-connector with restrictor GRO, Y-PK3</b>
<b>Valve function</b>	Flow control/silencer function	Flow control function	Flow control function
<b>Pneumatic connection 1</b>	M5, M7, R1/4, R1/8	M3, M5	G1/4, G1/8, M5, PK-3, QS-3, QS-4, QS-6
<b>Standard flow rate in flow control direction 6-&gt;0 bar</b>		33 ... 169 l/min	
<b>Standard nominal flow rate in flow control direction</b>		18 ... 95 l/min	85 ... 350 l/min
<b>Standard flow rate 6-&gt;0 bar</b>	0 ... 420 l/min		
<b>Adjusting element</b>	Knurled screw	Slotted head screw	Knurled screw
<b>Description</b>	<ul style="list-style-type: none"> <li>• With polymer silencer</li> </ul>	<ul style="list-style-type: none"> <li>• Flow control valve, flow control at both ends</li> <li>• Standard or mini flow control valve</li> <li>• Precision adjustment for low and medium speeds</li> <li>• Connections: thread at both ends, thread/push-in connector</li> <li>• Connections: elbow outlet or parallel outlet</li> <li>• Metal design</li> </ul>	<ul style="list-style-type: none"> <li>• Flow control valve, flow control at both ends</li> <li>• In-line flow control valve</li> <li>• Connections: push-in connector at both ends</li> <li>• Connections: in-line, Y-shape</li> <li>• Polymer design</li> </ul>
<b>online:</b> →	<a href="#">vffk</a>	<a href="#">grlo</a>	<a href="#">gro</a>

## Flow control valves





	 <b>Precision flow control valves GRPO</b>	 <b>Exhaust air flow control valves, flow control/silencers GRU, GRE</b>	 <b>Restrictors VMPA1-FT</b>
<b>Valve function</b>	Flow control function	Flow control/silencer function	Flow control function
<b>Pneumatic connection 1</b>	G1/8, PK-3, PK-4	G1/2, G1/4, G1/8, G3/4, G3/8	Sub-base
<b>Standard flow rate in flow control direction 6→0 bar</b>	5.2 ... 129 l/min		
<b>Standard nominal flow rate in flow control direction</b>	3.8 ... 75.8 l/min	520 ... 3600 l/min	3.5 ... 115 l/min
<b>Standard flow rate 6→0 bar</b>		0 ... 8000 l/min	
<b>Adjusting element</b>	Rotary knob with scale	Slotted head screw	
<b>Description</b>	<ul style="list-style-type: none"> <li>• Connections: threaded connection at both ends, push-in connector at both ends</li> <li>• Metal design</li> </ul>	<ul style="list-style-type: none"> <li>• Exhaust air flow control valve GRE: sintered metal</li> <li>• Flow control/silencer GRU: polymer</li> </ul>	<ul style="list-style-type: none"> <li>• Flow control function</li> <li>• Mounting: screw-in</li> </ul>
<b>online: →</b>	<a href="#">grpo</a>	<a href="#">gre</a>	<a href="#">vmpa1</a>

8





## Time delay valves

	 <b>Time delay valves, M5 Compact System VLK, VZ, VZO</b>	 <b>Time delay valves VZA, VZOA, VZB, VZOB</b>
<b>Pneumatic port</b>	PK-3	G1/4, G1/8
<b>Standard nominal flow rate</b>	60 ... 90 l/min	600 l/min
<b>Adjustable time delay</b>	0.25 ... 5 s	0 ... 30 s
<b>Operating pressure</b>	2.5 ... 8 bar	0 ... 10 bar
<b>Type of mounting</b>	Optional: front panel mounting, on mounting frame	With through-hole
<b>Description</b>	<ul style="list-style-type: none"> <li>• Complete system offering control components with all the functions required for pneumatic sequence controls</li> <li>• For control cabinet installation</li> <li>• Fast replacement of components</li> </ul>	<ul style="list-style-type: none"> <li>• Time delay infinitely adjustable</li> </ul>
<b>online: →</b>	<a href="#">m5-compact</a>	<a href="#">vza</a>

## Proportional valves



	 <b>Proportional flow control valves VPCF</b>	 <b>Proportional pressure regulators VPPX</b>	 <b>Proportional pressure regulators VPPM</b>	 <b>Proportional directional control valves VPWP</b>
<b>Valve function</b>	3-way proportional flow control valve	3-way proportional pressure regulator	3-way proportional pressure regulator	5/3-way proportional directional control valve, closed
<b>Pneumatic connection 1</b>	G3/8	G1/2, G1/4, G1/8, Sub-base	G1/2, G1/4, G1/8, Sub-base	G1/4, G1/8, G3/8
<b>Pressure regulation range</b>		0.1 ... 10 bar	0.02 ... 10 bar	
<b>Operating pressure for positioning/Soft Stop</b>				4 ... 8 bar
<b>Operating pressure</b>	1 ... 10 bar			0 ... 10 bar
<b>Standard nominal flow rate</b>	20 ... 1500 l/min	1400 ... 7000 l/min	380 ... 7000 l/min	350 ... 2000 l/min
<b>Description</b>	<ul style="list-style-type: none"> <li>• Linear characteristic curve for simple programming</li> <li>• ATEX-certified</li> <li>• Highly dynamic</li> <li>• Piston spool with integrated sensor</li> <li>• Electrical connection via M12x1 plug, 8-pin</li> </ul>	<ul style="list-style-type: none"> <li>• Pressure regulator with additional sensor input</li> <li>• Multi-sensor control (cascade control)</li> <li>• Control characteristic adjustable via FCT software</li> <li>• Integrated pressure sensor with separate output</li> <li>• Pressure is maintained if the controller fails</li> </ul>	<ul style="list-style-type: none"> <li>• Pilot actuated pressure regulator</li> <li>• Multi-sensor control (cascade control)</li> <li>• Integration in valve terminal MPA</li> <li>• User interface with LED displays, LCD display, adjustment/selection buttons</li> <li>• Integrated pressure sensor</li> <li>• Electrical connection via plug, round design, 8-pin, M12 or terminal linking</li> </ul>	<ul style="list-style-type: none"> <li>• Regulated piston spool valve</li> <li>• Digital actuation</li> <li>• Integrated pressure sensors for monitoring function and force control</li> <li>• With auto identification</li> <li>• Diagnostic function</li> <li>• Integrated digital output, e.g. for a clamping/brake unit</li> <li>• Suitable for servo-pneumatic applications with CPX-CMAX and CPX-CMPX</li> </ul>
<b>online: →</b>	<a href="#">vpcf</a>	<a href="#">vppx</a>	<a href="#">vppm</a>	<a href="#">vpwp</a>





## Proportional valves

	 <b>Proportional pressure regulators</b> <b>MPPE</b>	 <b>Proportional pressure regulators</b> <b>VPPE</b>	 <b>Proportional directional control valves</b> <b>MPYE</b>	 <b>Proportional directional control valves</b> <b>VPPL</b>
<b>Valve function</b>	3-way proportional pressure regulator, closed	3-way proportional pressure regulator, 3-way proportional pressure regulator, closed	5/3-way, closed	3-way proportional pressure regulator, closed
<b>Pneumatic connection 1</b>	G1/2, G1/4, G1/8	G1/8	G1/4, G1/8, G3/8, M5	G1/4, Flange
<b>Pressure regulation range</b>	0 ... 10 bar	0.02 ... 10 bar		0.2 ... 40 bar
<b>Operating pressure for positioning/Soft Stop</b>				
<b>Operating pressure</b>	≤12 bar	8 bar	0 ... 10 bar	≤50 bar
<b>Standard nominal flow rate</b>		310 ... 1250 l/min	100 ... 2000 l/min	300 l/min
<b>New</b>				• New series
<b>Description</b>	<ul style="list-style-type: none"> <li>• Directly actuated (G1/8), pilot actuated (G1/4, G1/2)</li> <li>• Setpoint value input as analogue voltage or current signal</li> <li>• Choice of pressure regulation ranges</li> <li>• Optionally with setpoint module</li> <li>• Electrical connection via plug, round design to DIN 45326, M16 x 0.75, 8-pin</li> </ul>	<ul style="list-style-type: none"> <li>• Pilot actuated pressure regulator</li> <li>• Setpoint input as analogue voltage signal (0 ... 10 V)</li> <li>• Electrical connection via M12x1 plug, 4-pin</li> <li>• Optionally with setpoint module</li> </ul>	<ul style="list-style-type: none"> <li>• Regulated piston spool valve</li> <li>• Analogue actuation</li> <li>• Setpoint input as analogue voltage signal (0 ... 10 V)</li> <li>• Suitable for servo-pneumatic applications with SPC11</li> </ul>	<ul style="list-style-type: none"> <li>• For high-pressure applications</li> <li>• Directly actuated piston regulator</li> <li>• Available in three variants: flanged valve, flanged valve with external pilot air supply, in-line valve</li> </ul>
<b>online: →</b>	<a href="#">mppes</a>	<a href="#">vppe</a>	<a href="#">mpye</a>	<a href="#">vppl</a>







## Electrically actuated process and media valves



	 <b>Solenoid valves</b> <b>VZWD</b>	 <b>Reverse jet pulse valves</b> <b>VZWE-E, VZWE-F</b>	 <b>Solenoid valves</b> <b>VZWF</b>
<b>Design</b>	Directly actuated poppet valve	Angled version, straight version with flange, diaphragm valve	Diaphragm valve, force pilot operated
<b>Type of actuation</b>	Electric	Electric	Electric
<b>Nominal width</b>	1 ... 6 mm	20 ... 76 mm	13.5 ... 50 mm
<b>Process valve connection</b>	G1/4, G1/8, NPT1/4, NPT1/8		G1, G1 1/2, G1 1/4, G1/2, G1/4, G2, G3/4, G3/8, NPT1, NPT1 1/2, NPT1 1/4, NPT1/2, NPT1/4, NPT2, NPT3/4, NPT3/8
<b>Process valve connection 1</b>		Flange diameter 60 mm, 75 mm, 89 mm, G1, G1 1/2, G2, G2 1/2, G3/4	
<b>Process valve connection 2</b>		Flange diameter 145.5 mm, 162 mm, 59 mm, 74 mm, G1, G1 1/2, G2, G2 1/2, G3/4	
<b>Temperature of medium</b>	-10 ... 80 °C		-10 ... 80 °C
<b>Operating pressure</b>	0 ... 90 bar	0.35 ... 8 bar	0 ... 10 bar
<b>Medium pressure of gaseous media</b>			
<b>Medium pressure of liquid media</b>			
<b>Flow rate Kv</b>	0.06 ... 0.4 m <sup>3</sup> /h	15 ... 210 m <sup>3</sup> /h	1.8 ... 28 m <sup>3</sup> /h
<b>Quick ordering of selected basic designs</b>	★		★
<b>Description</b>	<ul style="list-style-type: none"> <li>• Extensive pressure range</li> <li>• Directly actuated poppet valve</li> <li>• No pressure difference required</li> <li>• Can also be used in vacuum technology</li> </ul>	<ul style="list-style-type: none"> <li>• High flow rates</li> <li>• For mechanically cleaning filters and dust filter systems</li> <li>• Fast opening and closing times</li> <li>• Sturdy pilot system</li> </ul>	<ul style="list-style-type: none"> <li>• High flow rates</li> <li>• Large nominal diameters with relatively small solenoids</li> <li>• No pressure difference required</li> <li>• Can also be used in vacuum technology</li> </ul>
<b>online: →</b>	<a href="#">vzwd</a>	<a href="#">vzwe</a>	<a href="#">vzwf</a>

	 <b>Solenoid valves VZWM</b>	 <b>Solenoid valves VZWP</b>	 <b>Solenoid valves MN1H</b>
<b>Design</b>	Poppet valve with diaphragm seal	Piloted piston poppet valve	Diaphragm valve
<b>Type of actuation</b>	Electric	Electric	Electric
<b>Nominal width</b>	13 ... 50 mm	13 ... 25 mm	13 ... 40 mm
<b>Process valve connection</b>	G1, G1 1/2, G1 1/4, G1/2, G1/4, G2, G3/4, G3/8	G1, G1/2, G1/4, G3/4, G3/8, NPT1, NPT1/2, NPT1/4, NPT3/4, NPT3/8	G1, G1 1/2, G1/2, G1/4, G3/4, G3/8
<b>Process valve connection 1</b>			
<b>Process valve connection 2</b>			
<b>Temperature of medium</b>	-10 ... 60 °C	-10 ... 80 °C	-10 ... 60 °C
<b>Operating pressure</b>		0.5 ... 40 bar	0.5 ... 10 bar
<b>Medium pressure of gaseous media</b>	0.5 ... 10 bar		
<b>Medium pressure of liquid media</b>	0.5 ... 6 bar		
<b>Flow rate Kv</b>	1.6 ... 39 m <sup>3</sup> /h	1.5 ... 11.5 m <sup>3</sup> /h	
<b>Quick ordering of selected basic designs</b>			
<b>Description</b>	<ul style="list-style-type: none"> <li>• Poppet valve with diaphragm seal</li> <li>• Brass or stainless steel casting design</li> <li>• Electrical connection via solenoid armature</li> <li>• Wide range of coils</li> <li>• Coil can be ordered separately</li> </ul>	<ul style="list-style-type: none"> <li>• For all applications with a differential pressure of min. 0.5 bar</li> <li>• For high pressures and high flow rates with relatively small solenoids</li> <li>• For controlling gaseous and liquid media in open circuits</li> </ul>	<ul style="list-style-type: none"> <li>• Pilot operated diaphragm valve</li> <li>• Brass design</li> <li>• Can only be used for gaseous media</li> <li>• Adjustable closing cushioning, in-line mounting or through-hole</li> </ul>
<b>online:</b> →	<a href="#">vzwm</a>	<a href="#">vzwp</a>	<a href="#">mn1h-2</a>



8

## Pneumatically and mechanically actuated process and media valves



	 <b>Pinch valves VZQA</b>	 <b>Angle seat valves VZXF</b>	 <b>Ball valves VAPB</b>	 <b>Ball valves VZBC</b>
<b>Design</b>	Pinch valve, pneumatically actuated	Poppet valve with spring return	2-way ball valve	2-way ball valve
<b>Valve function</b>	2/2-way closed, monostable, 2/2-way open, monostable	2/2-way, closed, monostable		2/2
<b>Type of actuation</b>	Pneumatic	Pneumatic	Mechanical	Mechanical
<b>Nominal width</b>		12 ... 45 mm		
<b>Nominal width DN</b>	6 mm, 15 mm, 25 mm	15 mm, 20 mm, 25 mm, 32 mm, 40 mm, 50 mm	15 mm, 20 mm, 25 mm, 32 mm, 40 mm, 50 mm, 63 mm	15 mm, 20 mm, 25 mm, 32 mm, 40 mm, 50 mm, 65 mm, 80 mm, 100 mm
<b>Process valve connection</b>	G1, G1/2, G1/4, NPT1/2, NPT1/4, Clamp to ASME-BPE type A, clamp to ASME-BPE type B, clamp to DIN 32676 series A	G1, G1 1/2, G1 1/4, G1/2, G2, G3/4, NPT1, NPT1 1/2, NPT1 1/4, NPT1/2, NPT2, NPT3/4	Rp1, Rp1 1/2, Rp1 1/4, Rp1/2, Rp1/4, Rp2, Rp2 1/2, Rp3/4, Rp3/8	Ring housing with threaded flange
<b>Flow rate Kv</b>	0.7 ... 18 m <sup>3</sup> /h	3.3 ... 43 m <sup>3</sup> /h	5.9 ... 535 m <sup>3</sup> /h	19.4 ... 1414 m <sup>3</sup> /h
<b>Standard nominal flow rate</b>				
<b>Temperature of medium</b>	-5 ... 100 °C	-40 ... 200 °C	-20 ... 150 °C	-10 ... 200 °C
<b>Operating pressure</b>	0 ... 6 bar	-0.9 ... 40 bar		
<b>New</b>	<ul style="list-style-type: none"> <li>Additional connection size</li> <li>Modular, interchangeable component parts</li> </ul>			
<b>Quick ordering of selected basic designs</b>		★		
<b>Description</b>	<ul style="list-style-type: none"> <li>Modular design</li> <li>Quick and easy replacement of the diaphragm</li> <li>Selection of different materials for housing and connector caps</li> <li>Different connection cap designs (G and NPT thread), clamp ferrule to DIN 32676 and ASME-BPE)</li> <li>For critical, abrasive and viscous media</li> <li>Up to 2 million switching cycles</li> <li>FDA-compliant materials</li> <li>Easy-to-clean design</li> <li>Flow direction is freely selectable</li> </ul>	<ul style="list-style-type: none"> <li>Sturdy design</li> <li>Stainless steel and gunmetal process valves with stainless steel, brass or aluminium actuators</li> <li>For operating pressures up to 40 bar</li> <li>Safety position "closing"</li> <li>Different actuator sizes and housing materials</li> <li>Selection of different seat and shaft seals</li> <li>Flow direction is freely selectable</li> <li>For liquids, gases and other easily contaminated media</li> <li>Easy-to-clean design</li> </ul>	<ul style="list-style-type: none"> <li>Automatable 2-way ball valve</li> <li>Brass design</li> <li>Blow-out proof shaft</li> <li>Manual operation possible using hand lever</li> <li>Connecting thread to DIN 2999 or DIN ISO 228-1</li> <li>Mounting flange to ISO 5211</li> </ul>	<ul style="list-style-type: none"> <li>Automatable 2-way ball valve with compact flange</li> <li>Stainless steel design</li> <li>Short installation length</li> <li>Blow-out proof shaft</li> <li>Manual operation possible using hand lever</li> <li>Connecting thread to DIN 2999 or DIN ISO 228-1</li> <li>Mounting flange to ISO 5211</li> <li>ATEX certification for zone 1, 21, 2, 22</li> </ul>
<b>online:</b> →	<a href="#">vzqa</a>	<a href="#">vzxf</a>	<a href="#">vapb</a>	<a href="#">vzbc</a>

	 <b>Ball valve actuator units</b> <b>VZBC</b>	 <b>Ball valves</b> <b>VZBA</b>	 <b>Ball valve actuator units</b> <b>VZBA</b>
<b>Design</b>	2-way ball valve, quarter turn actuator	2-way ball valve, 3-way ball valve, L-shaped hole, T-shaped hole	2-way ball valve, 3-way ball valve, L-shaped hole, quarter turn actuator, T-shaped hole
<b>Valve function</b>		2/2, 3/2	
<b>Type of control</b>	Pneumatic	Mechanical	Pneumatic
<b>Nominal width</b>			
<b>Nominal width DN</b>	15 mm, 20 mm, 25 mm, 32 mm, 40 mm, 50 mm, 65 mm, 80 mm, 100 mm	8 mm, 10 mm, 15 mm, 20 mm, 25 mm, 32 mm, 40 mm, 50 mm, 65 mm, 80 mm, 100 mm	8 mm, 10 mm, 15 mm, 20 mm, 25 mm, 32 mm, 40 mm, 50 mm, 65 mm, 80 mm, 100 mm
<b>Process valve connection</b>	Ring housing with threaded flange	Rp1, Rp1 1/2, Rp1 1/4, Rp1/2, Rp1/4, Rp2, Rp2 1/2, Rp3, Rp3/4, Rp3/8, Rp4, Weld-on ends/weld-on ends	Rp1, Rp1 1/2, Rp1 1/4, Rp1/2, Rp1/4, Rp2, Rp2 1/2, Rp3, Rp3/4, Rp3/8, Rp4, Weld-on ends/weld-on ends
<b>Flow rate Kv</b>	19.4 ... 1414 m <sup>3</sup> /h	7 ... 1414 m <sup>3</sup> /h	7 ... 1414 m <sup>3</sup> /h
<b>Standard nominal flow rate</b>			
<b>Temperature of medium</b>	-10 ... 200 °C	-10 ... 200 °C	-10 ... 200 °C
<b>Operating pressure</b>			
<b>Description</b>	<ul style="list-style-type: none"> <li>• Ball valve actuator unit with double-acting or single-acting quarter turn actuator</li> <li>• Stainless steel ball valve in compact design</li> <li>• NAMUR port pattern for solenoid valves/sensor boxes to VDI/VDE 3845</li> <li>• Flow is fully opened or closed in both directions</li> <li>• ATEX certification for zone 1, 21, 2, 22</li> </ul>	<ul style="list-style-type: none"> <li>• Automatable 2-way or 3-way ball valve</li> <li>• Stainless steel design</li> <li>• Blow-out proof shaft</li> <li>• Manual operation possible using hand lever</li> <li>• Connecting thread to DIN 2999 or DIN ISO 228-1</li> <li>• Mounting flange to ISO 5211</li> <li>• ATEX certification for zone 1, 21, 2, 22</li> </ul>	<ul style="list-style-type: none"> <li>• Ball valve actuator unit with double-acting or single-acting quarter turn actuator</li> <li>• Stainless steel ball valve</li> <li>• NAMUR port pattern for solenoid valves/sensor boxes to VDI/VDE 3845</li> <li>• Flow is fully opened or closed in both directions</li> <li>• ATEX certification for zone 1, 21, 2, 22</li> </ul>
<b>online: →</b>	<a href="#">vzbc</a>	<a href="#">vzba</a>	<a href="#">vzba</a>

## Pneumatically and mechanically actuated process and media valves



	 <b>Pneumatic valves</b> <b>VLX</b>	 <b>Ball valve actuator units</b> <b>VZPR</b>
<b>Design</b>	Diaphragm valve	2-way ball valve, quarter turn actuator
<b>Type of actuation</b>	Pneumatic	Electric, pneumatic
<b>Nominal width</b>	13 ... 25 mm	
<b>Nominal width DN</b>		15 mm, 20 mm, 25 mm, 32 mm, 40 mm, 50 mm, 63 mm
<b>Process valve connection</b>	G1, G1/2, G1/4, G3/4, G3/8	Rp1, Rp1 1/2, Rp1 1/4, Rp1/2, Rp1/4, Rp2, Rp2 1/2, Rp3/4, Rp3/8
<b>Flow rate Kv</b>		
<b>Standard nominal flow rate</b>	2400 ... 14000 l/min	
<b>Temperature of medium</b>	-10 ... 80 °C	-20 ... 150 °C
<b>Operating pressure</b>	1 ... 10 bar	
<b>Description</b>	<ul style="list-style-type: none"> <li>• Poppet valve</li> <li>• Indirectly actuated</li> <li>• Brass design</li> <li>• In-line mounting or via through-holes</li> </ul>	<ul style="list-style-type: none"> <li>• Ball valve actuator unit with double-acting quarter turn actuator</li> <li>• Brass ball valve</li> <li>• NAMUR port pattern for solenoid valves/sensor boxes to VDI/VDE 3845</li> <li>• Flow is fully opened or closed in both directions</li> </ul>
<b>online: →</b>	<a href="#">vlx</a>	<a href="#">vzpr</a>

## Pneumatic control systems

	 <b>Quickstepper FSS</b>	 <b>Control blocks for two-hand start ZSB</b>	 <b>Pneumatic counters, M5 Compact System PZ, PZA, PZV</b>
<b>Design</b>	Sequencer, additive		Mechanical sequence counter with pneumatic drive
<b>Pneumatic connection</b>			M5
<b>Operating pressure</b>	2 ... 6 bar	4 ... 8 bar	2 ... 8 bar
<b>Type of mounting</b>		Optionally: with through hole, with female thread	Front panel mounting, with through-hole
<b>Description</b>	<ul style="list-style-type: none"> <li>• Pneumatic/mechanical sequencer with 12 steps and start logic circuits</li> <li>• Ready-to-install sequence controller</li> <li>• Feedback-controlled motion sequences</li> <li>• Fast replacement, tubing can be left in place</li> </ul>	<ul style="list-style-type: none"> <li>• Used wherever manual actuation poses a risk of accident to operating personnel</li> <li>• Safety component in accordance with EU Machinery Directive</li> </ul>	<ul style="list-style-type: none"> <li>• Complete system offering control components with all the functions required for pneumatic sequence controls</li> <li>• For control cabinet installation</li> <li>• Fast replacement of components</li> <li>• Available with protective cap</li> </ul>
<b>online: →</b>	<a href="#">fss</a>	<a href="#">zsb</a>	<a href="#">pza</a>

8

## Pneumatic control systems

	 <b>Timers, M5 Compact System PZVT, PZVT-S, PZVT-FR, PZVT-AUT</b>	 <b>Electric counters CCES</b>
<b>Design</b>	Mechanical sequence counter with pneumatic drive	Electric adding counter with battery
<b>Pneumatic connection</b>	Female thread M5	
<b>Operating pressure</b>	2 ... 6 bar	
<b>Type of mounting</b>	Front panel mounting	Front panel mounting
<b>Description</b>	<ul style="list-style-type: none"> <li>• Complete system offering control components with all the functions required for pneumatic sequence controls</li> <li>• For control cabinet installation</li> <li>• Fast replacement of components</li> <li>• Mechanical sequence counter with pneumatic drive</li> <li>• Adjustable time delay</li> <li>• Available with protective cap</li> </ul>	<ul style="list-style-type: none"> <li>• 8-digit LCD display</li> <li>• Independent power supply</li> <li>• Connection via terminal strip</li> <li>• Reset button</li> </ul>
<b>online: →</b>	<a href="#">pzvt</a>	<a href="#">cces</a>

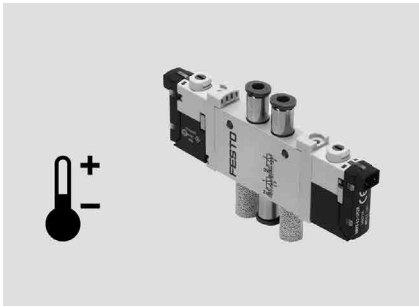

### Valves with customised designs

Can't find the valve you need in our catalogue?

We can offer you customised components that are tailored to your specific requirements – from minor product modifications to complete new product developments.

Common product modifications:

- Coatings for special ambient conditions
- Customised cables: length, pin allocation, pre-assembled with plug
- Modified actuating elements
- Modified connecting thread
- Modified valve sub-bases

Many additional variants are possible. Ask your Festo sales engineer, who will be happy to help.

Further information on customised components can be found on your local website

→ [www.festo.com](http://www.festo.com)

## Software tool

### Product finder for valve terminals





Find the right valve terminal quickly with the help of the product finder. Start the product finder by clicking on the blue button "Product finder" under "Products". Select your technical features on the left-hand side step-by-step; the selection of suitable products on the right-hand side is automatically updated to reflect the chosen technical features.

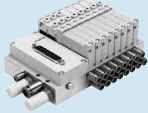

The use of logic checks ensures that only correct configurations are available for selection.

The product finder for valve terminals is part of the electronic catalogue and is not available as a separate software program.

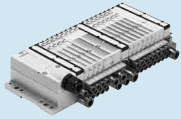
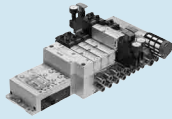

## Universal valve terminals

	 <b>Valve manifolds VTUG-S</b>	 <b>Valve terminals with multi-pin plug/fieldbus connection VTUG</b>	 <b>Valve manifolds VTUS</b>	 <b>Valve terminals MPA-L</b>
<b>Width</b>	10 mm, 14 mm, 18 mm	10 mm, 14 mm, 18 mm	21 mm, 26.5 mm, 31 mm	10 mm, 14 mm, 20 mm
<b>Standard nominal flow rate</b>	1380 l/min at 18 mm, 380 l/min at 10 mm, 780 l/min at 14 mm	1200 l/min at 18 mm, 330 l/min at 10 mm, 630 l/min at 14 mm	600 ... 2300 l/min	360 l/min at 10 mm, 670 l/min at 14 mm, 870 l/min at 20 mm
<b>Max. number of valve positions</b>	16	24	16	32
<b>Electrical actuation</b>	An individual connection	Fieldbus, multi-pin plug, IO-Link®, I-Port	An individual connection	Fieldbus, multi-pin plug, IO-Link®, I-Port
<b>Valve terminal design</b>	Fixed grid	Fixed grid	Fixed grid	Modular, valve sizes can be mixed
<b>New</b>		<ul style="list-style-type: none"> <li>Control cabinet cover for enhanced corrosion protection</li> </ul>	<ul style="list-style-type: none"> <li>Additional width</li> </ul>	<ul style="list-style-type: none"> <li>Check valve kit ducts 3 and 5 for MPA14 and MPA2 valves</li> </ul>
<b>Description</b>	<ul style="list-style-type: none"> <li>Compact with small VUVG valves</li> <li>Connection technology easy to change via the E-box</li> <li>Wide range of valve functions</li> <li>Also with semi in-line valves</li> </ul>	<ul style="list-style-type: none"> <li>Low-cost fixed grid</li> <li>Extremely easy assembly</li> <li>Exchangeable electrical actuation</li> <li>IO-Link® capable</li> <li>Valves VUVG with individual electrical connection can be integrated</li> <li>Also available with pneumatic multiple connector plate</li> </ul>	<ul style="list-style-type: none"> <li>Robust VUVS valves with long service life</li> <li>Individual electrical connection</li> <li>Pilot air supply in the manifold rail</li> <li>Comprehensive range of accessories</li> </ul>	<ul style="list-style-type: none"> <li>Maximum modularity</li> <li>Single granular</li> <li>Polymer sub-base</li> <li>3 valve sizes</li> <li>Fieldbus connection via CPX</li> <li>IO-Link® capable</li> </ul>
<b>online:</b> →	<a href="#">vtug</a>	<a href="#">vtug</a>	<a href="#">vtus</a>	<a href="#">mpa-l</a>

## Universal valve terminals

	 <b>Valve terminals MPA-S</b>	 <b>Valve terminals VTSA-F</b>	 <b>Valve terminals, Compact Performance CPV</b>
<b>Width</b>	10 mm, 20 mm	18 mm, 26 mm, 42 mm, 52 mm, 65 mm	10 mm, 14 mm, 18 mm
<b>Standard nominal flow rate</b>	360 l/min at 10 mm, 700 l/min at 20 mm	700 l/min at 18 mm, 1350 l/min at 26 mm, 1860 l/min at 42 mm, 2900 l/min at 52 mm, 4000 l/min at 65 mm	400 l/min at 10 mm, 800 l/min at 14 mm, 1600 l/min at 18 mm
<b>Max. number of valve positions</b>	64	32	8
<b>Electrical actuation</b>	Fieldbus, multi-pin plug, electrical terminal CPX, AS-Interface®, CP installation system	Ethernet, fieldbus, multi-pin plug, electrical terminal CPX, integrated controller, AS-Interface® connection	AS-Interface®, CPI installation system, individual connection, fieldbus, multi-pin plug
<b>Valve terminal design</b>	Modular, valve sizes can be mixed	Modular, valve sizes can be mixed	Fixed grid
<b>New</b>	<ul style="list-style-type: none"> <li>• Check valve kit ducts 3 and 5 for MPA2 valves</li> </ul>	<ul style="list-style-type: none"> <li>• Additional safety-oriented 5/3-way valves</li> </ul>	
<b>Description</b>	<ul style="list-style-type: none"> <li>• Valve terminals for universal applications</li> <li>• High-performance valves in a sturdy metal housing</li> <li>• Metal linking</li> <li>• Two valve sizes can be combined</li> <li>• Excellent communication thanks to serial linking</li> <li>• Fieldbus connection via CPX</li> <li>• Max. 128 valves</li> </ul>	<ul style="list-style-type: none"> <li>• Flow rate-optimised VTSA valve terminal</li> <li>• Linking with increased flow rates</li> <li>• Functions as per VTSA</li> </ul>	<ul style="list-style-type: none"> <li>• Maximum performance in the smallest of spaces</li> <li>• Three sizes</li> <li>• Wide range of connection and mounting options</li> <li>• Multi-pin or fieldbus control</li> <li>• IO-Link® capable</li> </ul>
<b>online: →</b>	<a href="#">mpa-s</a>	<a href="#">vtsa</a>	<a href="#">cpv</a>

## Universal valve terminals



	 <b>Valve manifolds, Compact Performance CPV10-EX</b>	 <b>Valve terminals CPV-SC</b>	 <b>Valve terminals VTUB-12</b>
<b>Width</b>	10 mm	10 mm	12 mm, 24 mm
<b>Standard nominal flow rate</b>	400 l/min, 400 l/min bei 10 mm	170 l/min at 10 mm	400 l/min at 12 mm
<b>Max. number of valve positions</b>	8	16	35
<b>Electrical actuation</b>	An individual connection	CPI installation system, individual connection, fieldbus, multi-pin plug	Fieldbus, multi-pin plug
<b>Valve terminal design</b>	Fixed grid	Fixed grid	Fixed grid
<b>Description</b>	<ul style="list-style-type: none"> <li>• Intrinsically safe valve manifold design to ATEX Category 2 (zone 1)</li> <li>• Optimised for control cabinet assembly</li> <li>• Optimal for pilot control of process valves</li> </ul>	<ul style="list-style-type: none"> <li>• Small and compact</li> <li>• High flow rate even with compact design</li> <li>• Suitable for vacuum</li> <li>• Multi-pin or fieldbus control</li> </ul>	<ul style="list-style-type: none"> <li>• Compact dimensions</li> <li>• Poppet valves in polymer technology</li> <li>• Multi-pin or fieldbus control</li> <li>• IO-Link® capable</li> </ul>
<b>online: →</b>	<a href="#">cpv10-ex</a>	<a href="#">cpv-sc</a>	<a href="#">vtub-12</a>



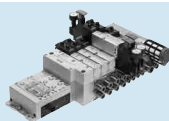



## Standards-based valve terminals



	 <b>Valve manifolds, to ISO 15407-1</b> <b>VTIA</b>	 <b>Valve terminals</b> <b>VTSA</b>
<b>Width</b>	18 mm, 26 mm	18 mm, 26 mm, 42 mm, 52 mm, 65 mm
<b>Max. standard nominal flow rate</b>	1100 l/min at 26 mm, 550 l/min at 18 mm	1100 l/min at 26 mm, 1300 l/min at 42 mm, 2900 l/min at 52 mm, 4000 l/min at 65 mm, 550 l/min at 18 mm
<b>Max. number of valve positions</b>	16	32
<b>Electrical actuation</b>	Individual connection	Individual connection, Ethernet, fieldbus, multi-pin plug, integrated controller
<b>Valve terminal design</b>	Modular, valve sizes can be mixed	Modular, valve sizes can be mixed
<b>New</b>		<ul style="list-style-type: none"> <li>Additional safety-oriented 5/3-way valves</li> </ul>
<b>Description</b>	<ul style="list-style-type: none"> <li>Conforms to ISO 15407-1</li> <li>Wide range of individual electrical connections</li> <li>Two valve sizes can be combined</li> </ul>	<ul style="list-style-type: none"> <li>Conforms to ISO 15407-2/ISO 5599-2</li> <li>Multi-pin plug connection or fieldbus connection via the CPX system</li> <li>Five valve sizes can be combined on one valve terminal</li> <li>Integrated safety functions</li> </ul>
<b>online: →</b>	<a href="#">vtia</a>	<a href="#">vtsa</a>

## Application-specific valve terminals

	 <b>Valve terminals</b> <b>MPA-C</b>	 <b>Valve terminals</b> <b>VTOC</b>	 <b>Valve terminals</b> <b>MH1</b>
<b>Width</b>	14 mm	10 mm	10 mm
<b>Standard nominal flow rate</b>	780 l/min at 14 mm	10 l/min at 10 mm	10 l/min at 10 mm
<b>Max. number of valve positions</b>	32	24	24
<b>Electrical actuation</b>	Multi-pin plug, IO-Link, I-Port	Multi-pin plug, IO-Link, I-Port	Individual connection, multi-pin plug
<b>Valve terminal design</b>	Modular and expandable	Fixed grid	Fixed grid
<b>New</b>	<ul style="list-style-type: none"> <li>Check valves in sub-base, ducts 3 and 5</li> </ul>		
<b>Description</b>	<ul style="list-style-type: none"> <li>Valve terminals in Clean Design</li> <li>Easy-to-clean design</li> <li>High corrosion resistance</li> <li>Protection class IP69K</li> <li>FDA-compliant materials</li> <li>Redundant sealing system</li> </ul>	<ul style="list-style-type: none"> <li>Compact pilot valves</li> <li>Compact assembly</li> <li>Greater safety thanks to interlock function</li> <li>Multi-pin or fieldbus control</li> <li>IO-Link® capable</li> </ul>	<ul style="list-style-type: none"> <li>Miniaturised poppet valves</li> <li>Multi-pin or electrical individual connection</li> </ul>
<b>online: →</b>	<a href="#">mpa-c</a>	<a href="#">vtoc</a>	<a href="#">mh1</a>

	 <b>Fieldbus modules</b> <b>CTEU</b>	 <b>CPI installation systems</b> <b>CTEC</b>	 <b>Terminal</b> <b>CPX</b>	 <b>Terminal</b> <b>CPX-P</b>
<b>Protocol</b>	Modbus® TCP, PROFIBUS DP, AS-Interface®, CANopen, CC-Link, CPI-B, DeviceNet, EtherCAT, EtherNet/IP, PROFINET	INTERBUS, DeviceNet, PROFIBUS, CANopen, CC-Link, Ether-Net/IP, PROFINET, EtherCAT, ModbusTCP	INTERBUS, DeviceNet, PROFIBUS, CANopen, CC-Link, Ether-Net/IP, PROFINET, EtherCAT, ModbusTCP	DeviceNet, PROFIBUS, EtherNet/IP, PROFINET, ModbusTCP
<b>Max. address capacity, inputs</b>	2 ... 64 byte	16 byte	64 byte	64 byte
<b>Max. address capacity, outputs</b>	2 ... 64 byte	16 byte	64 byte	64 byte
<b>Parameterisation</b>	Activate diagnostics, diagnostic behaviour, fail-safe and idle response, fail-safe response, watchdog disable, watchdog enable		Diagnostic behaviour, fail-safe response, forcing of channels, signal setup	Diagnostic behaviour, fail-safe response, forcing of channels, signal setup
<b>Degree of protection</b>	IP65, IP67	IP65, IP67	IP65, IP67	IP20, IP65
<b>Nominal operating voltage DC</b>	24 ... 30 V	24 V	24 V	24 V
<b>Operating voltage range DC</b>	18 ... 31.6 V	18 ... 30 V	18 ... 30 V	
<b>New</b>	<ul style="list-style-type: none"> <li>Further bus protocols</li> </ul>			
<b>Description</b>	<ul style="list-style-type: none"> <li>For valve terminals VTUB-12, VTUG, MPA-L, CPV, VTOC</li> <li>Can be expanded into the installation system CTEL</li> <li>Fieldbus-typical LEDs, interfaces and switching elements</li> <li>Isolated power supply for electronics and valves</li> </ul>	<ul style="list-style-type: none"> <li>CPX master module for four CPI strings</li> <li>Combination of centralised and decentralised installation possible</li> <li>Decentralised pneumatic components and sensors for fast processes</li> <li>Can be connected to valve terminal CPV, MPA-S, CPV-SC</li> </ul>	<ul style="list-style-type: none"> <li>Automation platform</li> <li>Open to all common fieldbus protocols and Ethernet</li> <li>Integrated diagnostic and maintenance functions</li> <li>Can be used as stand-alone remote I/O or with valve terminals MPA-S, MPA-L, VTSA/VTSA-F</li> <li>Choice of polymer or metal housing with individual linking</li> </ul>	<ul style="list-style-type: none"> <li>Use of matching remote I/O and valve terminals in a control cabinet</li> <li>Combination with modules of the electrical terminal CPX, which enables use for hybrid applications</li> <li>Unique modular structure</li> <li>Comprehensive integrated diagnostic and service functions</li> </ul>
<b>online:</b> →	<a href="#">cteu</a>	<a href="#">ctec</a>	<a href="#">cpx</a>	<a href="#">cpx-p</a>

Electrical peripherals

	 AS-Interface® components ASI, CACC	 Electrical interfaces CPX-CTEL	 AS-Interface® module CESA
<b>Protocol</b>		I-Port, IO-Link	AS-Interface®, CANopen, PROFIBUS
<b>Max. address capacity, inputs</b>		32 byte	
<b>Max. address capacity, outputs</b>		32 byte	
<b>Parameterisation</b>		Diagnostic behaviour, fail-safe mode per channel, force mode per channel, idle mode per channel, module parameter, tool changeover mode	
<b>Degree of protection</b>	IP65	IP65, IP67	IP20
<b>Nominal operating voltage DC</b>	24 V	24 V	AS-Interface® voltage 30 V DC
<b>Operating voltage range DC</b>	26.5 ... 31.6 V	18 ... 30 V	
<b>Description</b>	<ul style="list-style-type: none"> <li>• Accessories for AS-Interface® installation system</li> <li>• Modules for actuating individual valves ASI-EVA</li> <li>• Cable distributor ASI-KVT</li> <li>• Addressing device ASI-PRG-ADR</li> <li>• Compact I/O modules (IP65, IP67)</li> </ul>	<ul style="list-style-type: none"> <li>• CPX-CTEL master module with 4 I-Port connections</li> <li>• Decentralised pneumatic components and sensors for fast processes</li> <li>• Standardised M12 connections</li> </ul>	<ul style="list-style-type: none"> <li>• AS-Interface master gateway</li> <li>• Double address recognition</li> <li>• Direct operation via pushbuttons</li> <li>• Graphic display</li> <li>• Comprehensive diagnostics via LED and display</li> <li>• Specification 3.0</li> </ul>
<b>online: →</b>	<a href="#">as-interface</a>	<a href="#">cpx-ctel</a>	<a href="#">cesa</a>

9

Customised components – for your specific requirements



Valve terminals with customised designs

Can't find the valve terminal you need in our catalogue?

We can offer you customised components that are tailored to your specific requirements – from minor product modifications to complete new product developments.

Common product modifications:

- Coatings for special ambient conditions
- Customised cables: length, pin allocation, pre-assembled with plug
- Modified actuating elements
- Modified connecting thread
- Modified valve sub-bases

Many additional variants are possible. Ask your Festo sales engineer, who will be happy to help.

Further information on customised components can be found on your local website

→ [www.festo.com](http://www.festo.com)

## Configurator

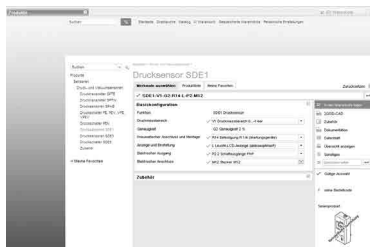

Design a product with numerous features reliably and quickly with the help of the configurator.

Select all the required product features step-by-step. The use of logic checks ensures that only correct configurations are available for selection.

The configurator is part of the electronic catalogue and is not available as a separate software program.

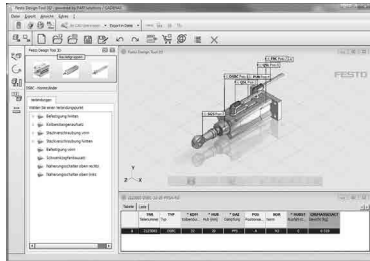
Festo Design Tool 3D  
FDT 3D

The Festo Design Tool 3D is a 3D product configurator for generating specific CAD product combinations from Festo. The configurator makes your search for the right accessory easier, more reliable and faster.





You can then order the module that has been created with a single order item – either completely pre-assembled or as individual parts in a single box. As a result, your bill of materials is considerably shortened and downstream processes such as product ordering, order picking and assembly are significantly simplified.

All ordering options are available in the following countries: AT, BE, CH, CZ, DE, DK, ES, FI, FR, GB, HU, IE, IT, NL, NO, PL, RU, SE, SI, SK.

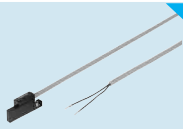

This tool can be found

- either via the address: [www.festo.com/FDT-3D](http://www.festo.com/FDT-3D) in the above listed countries,
- or on the CD "FDT 3D" (part no. 135595 for the above listed countries)
- or on the DVD.



## Proximity sensors, for T-slot

	 <b>Proximity sensor SDBT</b>	 <b>Proximity sensors SMT-8M-A</b>	 <b>Proximity sensors SME-8, SME-8M, SME-8-SL, SME-8-FM</b>	 <b>Proximity sensors SMT-8</b>
<b>Electrical connection</b>	M12x1, Cable, cable with plug, 2-pin, 3-pin, 2-wire, 3-wire, rotatable thread	M8x1, M12x1, Cable, cable with plug, 2-pin, 3-pin, 2-wire, 3-wire, rotatable thread	M8x1, Cable, cable with plug, plug, 3-pin, 2-wire, 3-wire, rotatable thread	M8x1, Cable, cable with plug, plug, 3-pin, 2-wire, 3-wire, rotatable thread
<b>Operating voltage range DC</b>	10 ... 30 V	5 ... 30 V	0 ... 230 V	10 ... 30 V
<b>Switching element function</b>	N/O contact	N/C contact, N/C contact or N/O contact, switchable, N/O contact	N/C contact, N/O contact	NAMUR, N/O
<b>Switching output</b>	NPN, PNP, non-contacting, 2-wire	NPN, PNP, PNP/NPN switchable, non-contacting, 2-wire	Contacting, bipolar, without LED function	NAMUR, PNP
<b>Quick ordering of selected basic designs</b>		★	★	
<b>New</b>	<ul style="list-style-type: none"> <li>EX6 design in accordance with the ATEX directive for explosive atmospheres</li> </ul>			
<b>Description</b>	<ul style="list-style-type: none"> <li>Measuring principle: magneto-resistive</li> <li>Oil-resistant, welding field-resistant, resistant to welding spatter</li> <li>Screw-clamped in slot, insertable from above</li> <li>LED switching status display</li> <li>Cable length 0.3 ... 5 m</li> </ul>	<ul style="list-style-type: none"> <li>Measuring principle: magneto-resistive</li> <li>Short design</li> <li>Variant EX2 for use in potentially explosive areas</li> <li>Insertable in the slot from above, flush with the cylinder profile</li> <li>LED switching status display</li> <li>LED operating reserve indication</li> <li>Cable length 0.1 ... 30 m</li> </ul>	<ul style="list-style-type: none"> <li>Measuring principle: magnetic reed</li> <li>SME-8-...-S6: heat-resistant design</li> <li>Variants suitable for use with energy chains and robots</li> <li>Screw-clamped or clamped in the slot, insertable in the slot from above or lengthwise</li> <li>LED switching status display</li> <li>Cable length 0.3, 2.5, 5, 7.5, 0.2 ... 10 m</li> </ul>	<ul style="list-style-type: none"> <li>Measuring principle: magneto-resistive</li> <li>SMT-8-F: in accordance with the ATEX directive for explosive atmospheres</li> <li>SMT-8G: design ideally matched to gripper sensing</li> <li>SMT-8-SL: sturdy thanks to long guides and plug directly at the sensor</li> <li>Variants suitable for use with energy chains and robots</li> <li>Insertable in the slot lengthwise or from above</li> <li>LED switching status display</li> <li>Cable length 0.3, 2.5, 5 m</li> </ul>
<b>online:</b> →	<a href="#">sdbt</a>	<a href="#">smt-8 m</a>	<a href="#">sme-8</a>	<a href="#">smt-8</a>



## Proximity sensors for T-slot

	 Proximity sensors CRSMT-8	 Proximity sensors SMEO-8E	 Proximity sensors SMTO-8E
<b>Electrical connection</b>	Cable, 3-wire	M8x1, M12x1, Cable, plug, 3-pin, 2-wire	M8x1, M12x1, Plug connector, 3-pin
<b>Operating voltage range DC</b>	10 ... 30 V	0 ... 250 V	10 ... 30 V
<b>Switching element function</b>	N/O contact	N/O contact	N/O contact
<b>Switching output</b>	PNP	Contacting, contacting bipolar, without LED function	NPN, PNP
<b>Description</b>	<ul style="list-style-type: none"> <li>Measuring principle: magneto-resistive</li> <li>Corrosion-resistant design</li> <li>Suitable for use in the food industry (see supplementary information on materials at <a href="http://www.festo.com/sp">www.festo.com/sp</a> &gt; Certificates), resistant to acids and cooling lubricants</li> <li>See supplementary information on food-safe materials at <a href="http://www.festo.com/sp">www.festo.com/sp</a> &gt; Certificates</li> <li>Insertable in the slot lengthwise, flush with the cylinder profile</li> <li>LED switching status display</li> <li>Cable length 2.5, 5 m</li> </ul>	<ul style="list-style-type: none"> <li>Measuring principle: magnetic reed</li> <li>Sturdy sensor in block design</li> <li>Plug integrated in housing</li> <li>LED switching status display</li> <li>Cable length 2.5 m</li> </ul>	<ul style="list-style-type: none"> <li>Measuring principle: magneto-resistive</li> <li>Sturdy sensor in block design</li> <li>Plug integrated in housing</li> <li>LED switching status display</li> </ul>
<b>online: →</b>	<a href="#">crsmt-8</a>	<a href="#">smeo</a>	<a href="#">smt0</a>



## Proximity sensors for T-slot

	 Proximity sensors SMTSO-8E	 Proximity sensors SMP0-8E
<b>Electrical connection</b>	M12x1, Plug connector, 3-pin	
<b>Operating voltage range DC</b>	10 ... 30 V	
<b>Switching element function</b>	N/O contact	
<b>Switching output</b>	NPN, PNP	
<b>Description</b>	<ul style="list-style-type: none"> <li>Measuring principle: magneto-inductive</li> <li>Welding field-resistant design</li> <li>Sturdy sensor in block design</li> <li>Plug integrated in housing</li> <li>LED switching status display</li> </ul>	<ul style="list-style-type: none"> <li>Measuring principle: magnetic</li> <li>Pneumatic proximity sensor</li> <li>Function: 3/2-way valve, normally closed</li> <li>Pneumatic connection via female thread M5</li> <li>Visual switching status indication</li> </ul>
<b>online: →</b>	<a href="#">smtso</a>	<a href="#">smpo</a>



## Proximity sensors, for C-slot

	 Proximity sensors <b>SME-10, SME-10M</b>	 Proximity sensors <b>SMT-10M, SMT-10G</b>
<b>Electrical connection</b>	M8x1, M12, Cable, cable with plug, open end, 2-pin, 3-pin, 3-wire, rotatable thread, snap collar	M8x1, M12, Cable, cable with plug, open end, 2-pin, 3-pin, 3-wire, rotatable thread, snap collar
<b>Operating voltage range DC</b>	5 ... 30 V	5 ... 30 V
<b>Switching element function</b>	N/O contact	N/O contact
<b>Switching output</b>	Contacting, bipolar	NPN, PNP, non-contacting, 2-wire
<b>Quick ordering of selected basic designs</b>	★	★
<b>Description</b>	<ul style="list-style-type: none"> <li>• Measuring principle: magnetic reed</li> <li>• Clamped in C-slot, insertable in the slot from above or lengthwise</li> <li>• LED switching status display</li> <li>• Cable length 0.3, 2.5 m</li> </ul>	<ul style="list-style-type: none"> <li>• Measuring principle: magneto-resistive</li> <li>• Clamped in C-slot, insertable in the slot from above or lengthwise</li> <li>• LED switching status display</li> <li>• Cable length 0.3, 2.5 m</li> </ul>
<b>online: →</b>	<a href="#">sme-10</a>	<a href="#">smt-10</a>



## Proximity sensors, round design

	 Proximity sensors <b>SMEO-4</b>	 Proximity sensors <b>CRSMEO-4</b>	 Proximity sensors <b>SMTO-4</b>
<b>Electrical connection</b>	M8x1, Cable, plug, 3-pin, 2-wire, 3-wire	Cable, 3-wire	M8x1, Cable, plug, 3-pin, 3-wire
<b>Operating voltage range DC</b>	12 ... 250 V	12 ... 30 V	10 ... 30 V
<b>Switching element function</b>	N/O contact	N/O contact	N/O contact
<b>Switching output</b>	Contacting, bipolar, without LED function	Contacting, bipolar	NPN, PNP
<b>Description</b>	<ul style="list-style-type: none"> <li>• Measuring principle: magnetic reed</li> <li>• U-shaped housing</li> <li>• LED switching status display</li> <li>• Cable length 2.5, 5 m</li> </ul>	<ul style="list-style-type: none"> <li>• Measuring principle: magnetic reed</li> <li>• Corrosion-resistant design</li> <li>• LED switching status display</li> <li>• Cable length 2.5 m</li> </ul>	<ul style="list-style-type: none"> <li>• Measuring principle: magneto-inductive</li> <li>• U-shaped housing</li> <li>• LED switching status display</li> <li>• Cable length 2.5 m</li> </ul>
<b>online: →</b>	<a href="#">smeo-4</a>	<a href="#">crsmeo-4</a>	<a href="#">smt-4</a>

## Proximity sensors, block design

	 Proximity sensors <b>SME-1</b>	 Proximity sensors <b>SMT-C1</b>	 Proximity sensors <b>SMEO-1</b>
<b>Electrical connection</b>	M8x1, Cable, plug, 3-pin, 2-wire, 3-wire	M8x1, M12x1, Cable, cable with plug, 3-pin, 3-wire, rotatable thread	M8x1, Cable, plug, 3-pin, 2-wire, 3-wire
<b>Operating voltage range DC</b>	0 ... 200 V	10 ... 30 V	0 ... 200 V
<b>Switching element function</b>	N/O contact	N/O contact	N/O contact
<b>Switching output</b>	Contacting, bipolar	PNP	Contacting, bipolar
<b>Description</b>	<ul style="list-style-type: none"> <li>Measuring principle: magneto-inductive</li> <li>For mounting kit</li> <li>With or without LED switching status indication</li> </ul>	<ul style="list-style-type: none"> <li>Measuring principle: magneto-inductive</li> <li>For Clean Design standards-based cylinder DSBF with mounting rail for sensors</li> <li>LED switching status display</li> </ul>	<ul style="list-style-type: none"> <li>Measuring principle: magnetic reed</li> <li>SMEO-1-S6: heat-resistant design</li> <li>With or without LED switching status indication</li> <li>Cable length 2.5, 5 m</li> </ul>
<b>online: →</b>	<a href="#">sme-1</a>	<a href="#">smt-c1</a>	<a href="#">smeo-1</a>

## Proximity sensor, block design





	 Proximity sensors <b>SMT0-1</b>	 Proximity sensors <b>SMTSO-1</b>	 Proximity sensors <b>SMPO-1</b>
<b>Electrical connection</b>	M8x1, Cable, plug, 3-pin, 3-wire	M12x1, Plug connector, 3-pin	
<b>Operating voltage range DC</b>	10 ... 30 V	10 ... 30 V	
<b>Switching element function</b>	N/O contact	N/O contact	
<b>Switching output</b>	NPN, PNP	PNP	
<b>Description</b>	<ul style="list-style-type: none"> <li>Measuring principle: magneto-resistive</li> <li>LED switching status display</li> <li>Cable length 2.5 m</li> </ul>	<ul style="list-style-type: none"> <li>Measuring principle: magneto-resistive</li> <li>Welding field immune design</li> <li>LED switching status display</li> </ul>	<ul style="list-style-type: none"> <li>Measuring principle: magnetic</li> <li>Pneumatic proximity sensor</li> <li>Function: 3/2-way valve, normally closed</li> <li>Pneumatic connection via barbed connector for tubing I. D. 3 mm</li> <li>Visual switching status indication</li> </ul>
<b>online: →</b>	<a href="#">smt0-1</a>	<a href="#">smtso-1</a>	<a href="#">smpo</a>





## Cylinder signal generators

	 <p><b>Cylinder signal generators</b> <b>PPL</b></p>
<b>Nominal flow rate</b>	48 l/min
<b>Operating pressure</b>	1 ... 8 bar
<b>Pneumatic connection</b>	Barbed connector for 3 mm I. D. plastic tubing
<b>Type of mounting</b>	Hollow bolt G1/8, G1/4
<b>Description</b>	<ul style="list-style-type: none"> <li>• For contactless pneumatic signal generation at the end of cylinder strokes</li> <li>• Function: 3/2-way valve, normally closed</li> <li>• Can be screwed directly into the supply port of the cylinder using a hollow bolt</li> </ul>
<b>online:</b> →	<a href="#">ppl</a>

## Inductive sensors



	 <p><b>Inductive sensors</b> <b>SIEA</b></p>	 <p><b>Inductive sensors</b> <b>SIED</b></p>	 <p><b>Inductive sensors</b> <b>SIEF</b></p>	 <p><b>Inductive sensors</b> <b>SIEH</b></p>
<b>Size</b>	M12, M18, M30, M8	M12, M18, M30	40x40x65 mm, M12, M18, M30, M8	3 mm, M12, M18
<b>Switching output</b>		Non-contacting, 2-wire	NPN, PNP	NPN, PNP
<b>Switching element function</b>		N/C contact, N/O contact	Antivalent, N/O contact	N/C contact, N/O contact
<b>Electrical connection</b>	M8x1, M12x1, Plug, 3-pin, 4-pin	M12x1, Cable, plug, 2-pin, 2-wire	M8x1, M12x1, Cable, plug, Fixcon, 3-pin, 4-pin, 3-wire	M8x1, M12x1, Cable, cable with plug, plug, 3-pin, 3-wire
<b>Operating voltage range DC</b>	15 ... 30 V	10 ... 320 V	10 ... 65 V	10 ... 30 V
<b>Description</b>	<ul style="list-style-type: none"> <li>• With analogue output</li> <li>• Flush installation</li> <li>• Metric thread</li> </ul>	<ul style="list-style-type: none"> <li>• With standard switching distance</li> <li>• For DC and AC voltage</li> <li>• Metric thread</li> <li>• Flush or non-flush mounting</li> <li>• LED switching status display</li> <li>• Design with metal or polyamide housing</li> </ul>	<ul style="list-style-type: none"> <li>• Reduction factor 1 for all metals</li> <li>• Welding field-resistant</li> <li>• Design with housing resistant to welding spatter</li> <li>• Flush, partially flush or non-flush mounting</li> <li>• LED switching status display</li> </ul>	<ul style="list-style-type: none"> <li>• With increased switching distance</li> <li>• Flush installation</li> <li>• Metric thread</li> <li>• LED switching status display</li> <li>• Design with stainless steel housing</li> </ul>
<b>online:</b> →	<a href="#">siea</a>	<a href="#">sied</a>	<a href="#">sief</a>	<a href="#">sieh</a>

## Inductive sensors



	 <b>Inductive sensors SIEN</b>	 <b>Inductive sensors SIES-Q</b>	 <b>Inductive sensors SIES-8M</b>
<b>Size</b>	4, 6.5, M12, M12x1, M18, M18x1, M30, M30x1.5, M5x0.5, M8x1	12x26x40, 15x20x30, 40x40x120, 5x5x25, 8x8x40, 8x8x59 mm	For T-slot
<b>Switching output</b>	NPN, PNP	NPN, PNP	NPN, PNP
<b>Switching element function</b>	N/C contact, N/O contact	Antivalent, N/C contact, N/O contact	N/C contact, N/O contact
<b>Electrical connection</b>	M8x1, M12x1, Cable, plug, 3-pin, 3-wire	M8x1, Cable, plug, screw terminal, 3-pin, 3-wire	M8x1, Cable, cable with plug, 3-pin, 3-wire, rotatable thread
<b>Operating voltage range DC</b>	10 ... 30 V	10 ... 30 V	10 ... 30 V
<b>Quick ordering of selected basic designs</b>	★		
<b>Description</b>	<ul style="list-style-type: none"> <li>• With standard switching distance</li> <li>• For DC voltage</li> <li>• Round design</li> <li>• Metric thread</li> <li>• Flush or non-flush mounting</li> <li>• LED switching status display</li> <li>• Design with metal or polyamide housing</li> </ul>	<ul style="list-style-type: none"> <li>• Block design</li> <li>• Flush installation</li> <li>• LED switching status display</li> </ul>	<ul style="list-style-type: none"> <li>• Suitable for position sensing for electric axes and grippers with T-slot</li> <li>• Flush installation</li> <li>• Switching status indication with 2 LEDs for better visibility regardless of the direction from which it is approached</li> </ul>
<b>online: →</b>	<a href="#">sien</a>	<a href="#">sies</a>	<a href="#">sies</a>

10



## Position sensors





	 <b>Position sensors SRBS</b>	 <b>Position transmitters SMAT-8E</b>	 <b>Position transmitters SDAT</b>
<b>Design</b>	Round	For T-slot	For T-slot
<b>Position measuring range</b>	>270°	48 ... 52 mm	0 ... 160 mm
<b>Analogue output</b>	50 mA	0–10 V, 4–20 mA	4–20 mA, 100 mA
<b>Electrical connection</b>	M8, Cable with plug, 4-pin, rotatable thread	M8x1, Plug connector, 4-pin	M8, Cable with plug, 4-pin, rotatable thread
<b>Quick ordering of selected basic designs</b>	★		
<b>Description</b>	<ul style="list-style-type: none"> <li>• Used to detect rotation of the shaft on rotary drives DRVS and DSM</li> <li>• The sensor can be quickly assembled without having to manually search for switching points</li> <li>• Simple and reliable operation using just one pushbutton directly on the device</li> </ul>	<ul style="list-style-type: none"> <li>• Measuring principle: magnetic Hall</li> <li>• Current and voltage signal at the analogue output</li> <li>• Insertable in the slot lengthwise</li> <li>• Suitable for use with energy chain and robot lines</li> <li>• LED status indications</li> <li>• Cable length 2.5, 5 m</li> </ul>	<ul style="list-style-type: none"> <li>• Measuring principle: magnetic Hall</li> <li>• Insertable in the slot from above, secured with screw</li> <li>• Suitable for use with energy chain and robot lines</li> <li>• LED status indications</li> <li>• Cable length 0.3 m</li> </ul>
<b>online: →</b>	<a href="#">srbs</a>	<a href="#">smat-8e</a>	<a href="#">sdatt</a>

## Position sensors

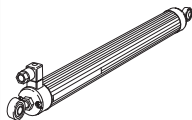



	 <b>Position transmitters SMAT-8M</b>	 <b>Position sensors SMH</b>
<b>Design</b>	For T-slot	For gripper
<b>Position measuring range</b>	40 mm	
<b>Analogue output</b>	0–10 V	
<b>Electrical connection</b>	M8x1, Cable with plug, 4-pin, rotatable thread	M8x1, Cable with plug, 4-pin
<b>Description</b>	<ul style="list-style-type: none"> <li>• Measuring principle: magnetic Hall</li> <li>• Displacement-proportional analogue output signal</li> <li>• Insertable in the slot from above, central clamping</li> <li>• Suitable for use with energy chain and robot lines</li> <li>• LED status indications</li> <li>• Cable length 0.3 m</li> </ul>	<ul style="list-style-type: none"> <li>• Measuring principle: magnetic Hall</li> <li>• 3 gripper positions can be detected using an evaluation unit</li> <li>• Freely selectable switching points</li> </ul>
<b>online:</b> →	<a href="#">smat-8 m</a>	<a href="#">smh-s1</a>

## Position sensors

	 <b>Displacement encoders MME-MTS-TLF</b>	 <b>Displacement encoders MLO-POT-TLF</b>	 <b>Displacement encoders MLO-POT-LWG</b>
<b>Stroke</b>	225 ... 2000 mm	225 ... 2000 mm	100 ... 750 mm
<b>Measuring principle of displacement encoder</b>	Digital	Analogue	Analogue
<b>Output signal</b>	CAN protocol type SPC-AIF	Analogue	Analogue
<b>Displacement resolution</b>	<0.01 mm	0.01 mm	0.01 mm
<b>Description</b>	<ul style="list-style-type: none"> <li>• Measuring principle: magnetostrictive</li> <li>• Contactless with absolute measurement</li> <li>• High travel speed</li> <li>• System product for servo-pneumatic positioning technology and Soft Stop</li> </ul>	<ul style="list-style-type: none"> <li>• Conductive plastic potentiometer</li> <li>• Absolute measurement with high resolution</li> <li>• High travel speed and long service life</li> <li>• Several mounting options on pneumatic linear drives DGPL</li> <li>• Plug-in connections</li> </ul>	<ul style="list-style-type: none"> <li>• Connecting rod potentiometer</li> <li>• Absolute measurement with high resolution</li> <li>• Long service life</li> <li>• High protection class</li> <li>• Plug-in connections</li> </ul>
<b>online:</b> →	<a href="#">mme</a>	<a href="#">mlo</a>	<a href="#">mlo</a>



	 <b>Pressure sensors SPAN</b>	 <b>Pressure sensors SPAE</b>	 <b>Pressure sensors SPAU</b>	 <b>Pressure sensors SPAW</b>
<b>Pressure measuring range</b>	-1 ... 16 bar	-1 ... 10 bar	-1 ... 16 bar	-1 ... 100 bar
<b>Switching element function</b>	N/C or N/O contact, switchable	N/C contact, N/O contact, switchable	N/C or N/O contact, switchable	Switchable
<b>Pneumatic connection</b>	Male thread G1/8, NPT1/8-27, R1/8, female thread G1/8, M5, QS-4	Push-in sleeve QS-4, QS-6, QS-3, QS-4, flange	G1/8, M5, M7, NPT1/8-27, QS-4, QS-5/32, QS-6, R1/4, R1/8	Male thread G1/2, female thread G1/4
<b>Electrical connection</b>	Plug connector, square design, 4-pin	Cable, open end, 3-wire	M8x1, M12x1, Plug, round design, to EN 60947-5-2, 4-pin	M12x1, Plug, round design, to EN 60947-5-2, 4-pin, 5-pin
<b>Display type</b>	Illuminated LCD	LED display, 2-digit	Illuminated LCD, LED	4-character alphanumeric, LED indicator
<b>New</b>	<ul style="list-style-type: none"> <li>• New series</li> </ul>			
<b>Description</b>	<ul style="list-style-type: none"> <li>• For monitoring compressed air and non-corrosive gases</li> <li>• For network monitoring, regulator monitoring, leak test, object detection</li> <li>• Relative method of measurement based on a piezoresistive measuring cell</li> <li>• Serial communication integrated using IO-Link® 1.1</li> </ul>	<ul style="list-style-type: none"> <li>• Electronic pressure sensor with piezoresistive pressure measuring cell, integrated signal processing, numeric pressure indicator in percent, operating key and a switching output, PNP/NPN switchable</li> <li>• Display of minimum and maximum readings</li> <li>• All parameters entered can be transferred to other SPAEs (replicator function)</li> </ul>	<ul style="list-style-type: none"> <li>• For monitoring compressed air and non-corrosive gases</li> <li>• With or without display</li> <li>• Transfer of the pressure value as switch signal, analogue signal or via IO-Link® to the connected control system</li> </ul>	<ul style="list-style-type: none"> <li>• Highly robust</li> <li>• For liquid and gaseous media</li> <li>• Quick and easy setting of the switching outputs using three pushbuttons</li> <li>• Display is easy to read in any installation position</li> </ul>
<b>online: →</b>	<a href="#">span</a>	<a href="#">spae</a>	<a href="#">spau</a>	<a href="#">spaw</a>

## Pressure and vacuum sensors



	 Pressure switches SPBA	 Pressure transmitters SPTE	 Pressure transmitters SPTW	 Pressure sensors SPAB
<b>Pressure measuring range</b>		-1 ... 10 bar	-1 ... 100 bar	-1 ... 10 bar
<b>Switching element function</b>	Antivalent, changeover switch			Switchable
<b>Pneumatic connection</b>	G1/8	Push-in sleeve QS-4, QS-6, QS-3, QS-4, flange	G1/4	Male thread G1/8, NPT1/8-27, R1/8, female thread M5
<b>Electrical connection</b>	M12x1, Plug, round design, to EN 60947-5-2, 4-pin	Cable, open end, 3-wire	M12x1, Plug, round design, to EN 60947-5-2, 4-pin	M8x1, Cable, plug, round design, square design, to EN 60947-5-2, 4-pin, 4-wire
<b>Display type</b>				Illuminated LCD, multi-colour
<b>Description</b>	<ul style="list-style-type: none"> <li>Pressure sensor with permanently set switching point</li> <li>For solenoid valve VSVA</li> <li>Mounting: screw-in</li> </ul>	<ul style="list-style-type: none"> <li>Piezoresistive pressure sensor</li> <li>Measured variable: relative pressure</li> <li>Cable length 2.5 m</li> </ul>	<ul style="list-style-type: none"> <li>Sensor versions: piezoresistive pressure sensor or metal thin-film pressure sensor</li> <li>Measured variable: relative pressure</li> </ul>	<ul style="list-style-type: none"> <li>Relative pressure measurement</li> <li>Switching output PNP, NPN and analogue output</li> <li>Two-part, multi-coloured display</li> <li>Easy commissioning thanks to intuitive operation</li> <li>Compact design 30x30 mm</li> <li>Certification: c UL us Listed (OL), C-Tick</li> </ul>
<b>online:</b> →	<a href="#">spba</a>	<a href="#">spte</a>	<a href="#">sptw</a>	<a href="#">spab</a>

10

## Pressure and vacuum sensors



	 Pressure switches, vacuum switches PEV, VPEV	 PE converters PEN, PE, VPE	 Pressure sensors SDE1
<b>Pressure measuring range</b>	-1 ... 10 bar	-1 ... 0 bar	-1 ... 10 bar
<b>Switching element function</b>	Changeover switch	N/O contact, changeover switch	Switchable
<b>Pneumatic connection</b>	G1/4, G1/8, M5	G1/8, M5, PK-3, PK-4	G1/8, QS-4, R1/4, R1/8
<b>Electrical connection</b>	M8x1, M12x1, Plug, screw terminal, round design, square design, to DIN 43650, to EN 60947-5-2, type A, 4-pin	Cable, screw terminal, 3 connector leads, open end, 3-wire, 4-wire	M8x1, M12x1, Cable with plug, plug, round design, to EN 60947-5-2, 3-pin, 4-pin
<b>Display type</b>			Illuminated LCD, back-lit LCD
<b>Description</b>	<ul style="list-style-type: none"> <li>Mechanical pressure and vacuum switch</li> <li>Adjustable switching point</li> <li>Mounting: screw-in, via through-holes or via H-rail</li> <li>Visual scale for pressure adjustment</li> <li>Certification: CCC</li> </ul>	<ul style="list-style-type: none"> <li>Pneumatic/electric differential pressure switch</li> <li>Pneumatic/electric pressure transducer</li> <li>Design for vacuum</li> <li>Mounting on mounting frame 2 N</li> <li>Splash-proof design</li> <li>Certification: CCC</li> </ul>	<ul style="list-style-type: none"> <li>Five pressure measuring ranges</li> <li>Measurement of relative or differential pressure</li> <li>Switching output PNP, NPN and with analogue current or voltage output</li> <li>LCD or illuminated LCD display</li> <li>Mounting: via H-rail, via wall/surface bracket, mounting on service unit, front panel mounting</li> <li>Certification: c UL us Listed (OL), C-Tick</li> </ul>
<b>online:</b> →	<a href="#">pev</a>	<a href="#">pen</a>	<a href="#">sde1</a>

## Pressure and vacuum sensors



	 <b>Pressure sensors SDE3</b>	 <b>Pressure sensors SDE5</b>
<b>Pressure measuring range</b>	-1 ... 10 bar	-1 ... 10 bar
<b>Switching element function</b>	Switchable	N/C contact, N/O contact, switchable
<b>Pneumatic connection</b>	QS-4, QS-5/32	QS-1/4, QS-4, QS-5/32, QS-6
<b>Electrical connection</b>	M8x1, M12x1, Cable, cable with plug, plug, round design, to EN 60947-5-2, 4-pin, 5-pin	M8x1, Cable, plug, round design, to EN 60947-5-2, 3-pin, 3-wire
<b>Display type</b>	Illuminated LCD	
<b>Quick ordering of selected basic designs</b>		★
<b>Description</b>	<ul style="list-style-type: none"> <li>• Five pressure measuring ranges</li> <li>• Measurement of relative or differential pressure or two independent pressure inputs</li> <li>• Switching output 2x PNP or 2x NPN</li> <li>• Numerical and graphical pressure indication</li> <li>• Mounting: via H-rail, via wall/surface bracket, front panel mounting, with through-holes</li> <li>• Certification: C-Tick, ATEX, c UL us Listed (OL)</li> </ul>	<ul style="list-style-type: none"> <li>• Programmable and configurable pressure switch for simple pressure sensing tasks</li> <li>• Threshold/window comparator</li> <li>• Switching point adjustment by teach-in function</li> <li>• Integrated microprocessor</li> <li>• Switching status indicated by an LED visible from all sides</li> <li>• Certification: c UL us listed (OL), C-Tick</li> </ul>
<b>online:</b> →	<a href="#">sde3</a>	<a href="#">sde5</a>

10





## Flow sensors

	 <b>Flow sensors SFAW</b>	 <b>Flow sensors SFAB</b>	 <b>Flow sensors SFAM</b>
<b>Flow measuring range final value</b>	32 ... 100 l/min	10 ... 1000 l/min	1000 ... 15000 l/min
<b>Operating medium</b>	Liquid media, water, neutral liquids	Compressed air to ISO 8573-1:2010 [7:4:4], ISO 8573-1:2010 [6:4:4], nitrogen	Compressed air to ISO 8573-1:2010 [7:4:4], nitrogen
<b>Operating pressure</b>	0 ... 12 bar	0 ... 10 bar	0 ... 16 bar
<b>Pneumatic connection</b>		QS-1/4, QS-10, QS-12, QS-3/8, QS-5/16, QS-6, QS-8	G1, G1 1/2, G1/2, NPT1 1/2-11 1/2, NPT1-11 1/2, NPT1/2-14, Manifold module
<b>Electrical connection</b>	M12x1, Straight plug, 5-pin, A-coded	M12x1, Straight plug, 5-pin	M12x1, Straight plug, 5-pin
<b>New</b>	• New series		
<b>Description</b>	<ul style="list-style-type: none"> <li>• Cooling circuit monitoring, leakage or line break monitoring, process water monitoring, fill level monitoring</li> <li>• Input connection: clamped terminal connection DN15, DN20, barbed hose fitting 13 mm, female thread G1/2, G3/4, G1, user-specific connection</li> <li>• With optional integrated temperature sensor</li> <li>• Connection to higher-level systems is provided by two switching outputs, an analogue output and/or an IO-Link interface</li> <li>• Certification: RCM, c UL us Listed (OL)</li> </ul>	<ul style="list-style-type: none"> <li>• Flow sensor with integrated digital display</li> <li>• With unidirectional flow input</li> <li>• Mounting: H-rail mounting, wall or surface mounting</li> <li>• Certification: C-Tick</li> </ul>	<ul style="list-style-type: none"> <li>• Stand-alone device or combined with MS series service units</li> <li>• Supplies absolute flow information and accumulated air consumption measurements</li> <li>• Covers large measuring range with great precision thanks to high dynamic response</li> <li>• Large, illuminated LCD display</li> </ul>
<b>online:</b> →	<a href="#">sfaw</a>	<a href="#">sfab</a>	<a href="#">sfam</a>





## Flow sensors

	 <b>Flow sensors</b> <b>SFE3</b>	 <b>Flow sensors</b> <b>SFET</b>	 <b>Flow indicators</b> <b>SFEV</b>
<b>Flow measuring range final value</b>	0.5 ... 50 l/min	0.05 ... 50 l/min	
<b>Operating medium</b>	Compressed air to ISO 8573-1:2010 [1:4:2], nitrogen	Compressed air to ISO 8573-1:2010 [1:4:2], nitrogen	
<b>Operating pressure</b>	-0.7 ... 7 bar	-0.9 ... 7 bar	
<b>Pneumatic connection</b>	Female thread G1/8, QS-6	Female thread G1/8, QS-4, QS-6	
<b>Electrical connection</b>	Cable	Cable	Cable
<b>Description</b>	<ul style="list-style-type: none"> <li>Flow sensor with integrated digital display</li> <li>With unidirectional flow input</li> <li>Mounting: via through-holes or mounting bracket</li> <li>Electrical connection via open cable end</li> <li>Cable length 1 m</li> <li>Certification: C-Tick</li> </ul>	<ul style="list-style-type: none"> <li>With unidirectional (SFET-F) or bidirectional (SFET-R) flow input</li> <li>Mounting: via through-holes or mounting bracket</li> <li>Electrical connection via open cable end</li> <li>Cable length 1 m, 3 m</li> <li>Certification: C-Tick</li> </ul>	<ul style="list-style-type: none"> <li>For flow sensor SFET</li> <li>3 1/2-digit alphanumeric display</li> <li>Indicating range: 0.05 ... 50 l/min (flow sensor SFET-F); 0.05 ... 10 l/min (flow sensor SFET-R)</li> </ul>
<b>online:</b> →	<a href="#">sfe3</a>	<a href="#">sfet</a>	<a href="#">sfev</a>

## Opto-electronic sensors

	 <b>Diffuse sensors, retro-reflective sensors</b> <b>SOEG-RT, SOEG-RS</b>	 <b>Through-beam sensors</b> <b>SOEG-E, SOEG-S</b>	 <b>Fibre-optic units</b> <b>SOEG-L</b>	 <b>Laser diffuse sensors, laser retro-reflective sensors</b> <b>SOEL-RT, SOEL-RS</b>
<b>Method of measurement</b>	Distance sensor, retro-reflective sensor, diffuse sensor, diffuse sensor with background suppression, for transparent objects	Through-beam sensor, receiver, transmitter	Fibre-optic unit	Distance sensor, retro-reflective sensor, diffuse sensor, diffuse sensor with background suppression
<b>Working range</b>	0 ... 5500 mm	0 ... 20000 mm	0 ... 250 mm	0 ... 20000 mm
<b>Size</b>	20x32x12 mm, 30x30x15 mm, 4 mm, 50x50x17 mm, M12, M12x1, M18, M18x1, M5x0.5	20x32x12 mm, 30x30x15 mm, 50x50x17 mm, M18x1	20x32x12 mm, 30x30x15 mm	20x32x12 mm, 50x50x17 mm
<b>Type of light</b>	Infrared, red, red polarised	Infrared, red	Red	Laser, pulsed laser, red, red 650 nm, red polarised
<b>Switching output</b>	NPN, PNP	NPN, PNP	NPN, PNP	NPN, PNP
<b>Description</b>	<ul style="list-style-type: none"> <li>Round or block design</li> <li>Setting option: teach-in via button and via electrical connection</li> <li>Electrical connection via open cable end or plug connector</li> </ul>	<ul style="list-style-type: none"> <li>Round or block design</li> <li>Setting option: teach-in, teach-in via electrical connection, potentiometer</li> <li>Electrical connection via open cable end or plug connector</li> </ul>	<ul style="list-style-type: none"> <li>Block design</li> <li>Setting option: teach-in, teach-in via electrical connection, potentiometer</li> <li>Electrical connection via open cable end or plug connector</li> </ul>	<ul style="list-style-type: none"> <li>Setting option: teach-in, teach-in via electrical connection, potentiometer</li> <li>Electrical connection via open cable end or plug connector</li> </ul>
<b>online:</b> →	<a href="#">soeg</a>	<a href="#">soeg</a>	<a href="#">soeg</a>	<a href="#">soel</a>

## Opto-electronic sensors





	 <b>Colour sensors SOEC</b>	 <b>Fibre-optic units SOE4</b>	 <b>Fork light barriers SOOF</b>	 <b>Fibre-optic cables SOEZ, SOOC</b>
<b>Method of measurement</b>	Colour sensor	Fibre-optic unit	Fork light barrier	Through-beam sensor, fixed focus, fork light barrier, fibre-optic cable, diffuse sensor
<b>Working range</b>	12 ... 32 mm	2 ... 2000 mm		2 ... 650 mm
<b>Size</b>	50x50x17 mm		Fork 120x60 mm, 30x35 mm, 50x55 mm, 80x55 mm	M3, M4, M6, Fork pit 5x29 mm, fork pit 41x15x7 mm, rectangle 10x10x5 mm, rectangle 13x19.9x5 mm, rectangle 19x25x6 mm
<b>Type of light</b>	White	Red	Red	
<b>Switching output</b>	PNP	NPN, PNP	NPN, PNP	
<b>Description</b>	<ul style="list-style-type: none"> <li>• Diffuse sensor</li> <li>• Block design</li> <li>• Setting option: teach-in, teach-in via electrical connection</li> <li>• Electrical connection via M12x1 plug, 8-pin</li> <li>• Display via 7 LEDs</li> </ul>	<ul style="list-style-type: none"> <li>• Use for precise and space-saving position sensing in electronics and light assembly</li> <li>• Switching frequencies of up to 8000 Hz</li> <li>• Operational with fibre-optic cable SOOC as accessory</li> <li>• Variants: LED or LED display, timer function</li> <li>• Setting option: teach-in</li> <li>• Mounting: H-rail mounting or via through-holes</li> <li>• With protection against mutual interference</li> </ul>	<ul style="list-style-type: none"> <li>• Through-beam sensor with minimal installation effort</li> <li>• Design: polymer or metal</li> <li>• Sturdy housing: high shock and vibration resistance</li> <li>• IP67 degree of protection</li> <li>• Electrical connection via M8x1 plug, 3-pin</li> <li>• Setting option: potentiometer or teach-in</li> <li>• LED displays</li> </ul>	<ul style="list-style-type: none"> <li>• Cable connection, push-in connector</li> </ul>
<b>online:</b> →	<a href="#">soec</a>	<a href="#">soe4</a>	<a href="#">soof</a>	<a href="#">soez</a>

## Signal converters

	 <b>Signal converters SVE4</b>
<b>Signal range</b>	0–10 V +/-0.3, 0–20 mA +/-0.6, Adapted for position sensors SMH-S1-HG
<b>Switching output</b>	2xNPN, 2xPNP
<b>Switching function</b>	Freely programmable
<b>Electrical connection, output</b>	M8x1, Plug, 4-pin, to EN 60947-5-2
<b>Electrical connection, input</b>	M8x1, Socket, 4-pin, to EN 60947-5-2
<b>Description</b>	<ul style="list-style-type: none"> <li>• Converts analogue signals into switching points</li> <li>• Switching function freely programmable with teach-in</li> <li>• Threshold value, hysteresis or window comparator</li> <li>• Mounting: H-rail mounting or via adapter plate</li> <li>• LED switching status display</li> <li>• Certification: c UL us Listed (OL), C-Tick</li> </ul>
<b>online:</b> →	<a href="#">sve4</a>





## Air gap sensors



	 <b>Air gap sensors SOPA</b>	 <b>Micro reflex sensors, reflex sensors RML, RFL</b>	 <b>Back pressure end stops SD-2, SD-3, SD-3-N</b>	 <b>Air barriers SFL, SML</b>
<b>Sensing range</b>	20 ... 200 µm	Distance between nozzles 4.8 ... 5.1 mm, 4.5 ... 15.5 mm	Distance between nozzles 0 ... 0.5 mm	Distance between nozzles 5 ... 50 mm, up to 100 mm
<b>Operating pressure</b>	4 ... 7 bar	0.075 ... 0.5 bar, 0.1 ... 1.5 bar	0 ... 8 bar	0.1 ... 0.4 bar, 0.1 ... 4 bar, 0 ... 8 bar
<b>Display type</b>	Illuminated LCD, multi-colour	Signal pressure ≥0.5 mbar	Pressure signal 0 ... 8 bar	Pressure signal
<b>Operating medium</b>	Compressed air to ISO 8573-1:2010 [7:4:4]	Filtered, unlubricated compressed air	Compressed air, filtered, lubricated or unlubricated	Filtered, unlubricated compressed air
<b>Description</b>	<ul style="list-style-type: none"> <li>• Convenient solution for high-precision contact and distance monitoring</li> <li>• Setting option: teach-in or numerical setting using three-button operation</li> <li>• Integrated air jet function</li> <li>• Multi-coloured LCD display</li> <li>• Mounting: H-rail mounting, wall mounting, through-hole</li> <li>• Certification: C-Tick</li> </ul>	<ul style="list-style-type: none"> <li>• Back pressure actuated valve</li> <li>• For contactless sensing of indicating instruments, checking pressing and stamping tools, edge control, magazine control, for measuring and counting</li> <li>• Can be used even in very dirty environments, in complete darkness, with translucent or magnetic objects</li> </ul>	<ul style="list-style-type: none"> <li>• Can be used for stroke-dependent signal generation as a limit switch and fixed stop</li> <li>• Ideal for end-position sensing and position control with high accuracy requirements and small actuating forces</li> <li>• SD-3-N for sensing fluid levels and heavily foaming liquids</li> <li>• For use in inaccessible places</li> </ul>	<ul style="list-style-type: none"> <li>• Sender nozzle, receiver nozzle, gap sensor</li> <li>• Back pressure actuated valve</li> <li>• Operational reliability even in very dirty environments</li> <li>• Reliable even with high ambient temperatures</li> <li>• Insensitive to mechanical influences and sound waves</li> <li>• Reliable even in complete darkness and when sensing translucent objects</li> </ul>
<b>online:</b> →	<a href="#">sopa</a>	<a href="#">rfl</a>	<a href="#">sd</a>	<a href="#">sfl</a>

10

## Sensor boxes

	 <b>Sensor boxes SRBG</b>	 <b>Sensor boxes SRBC</b>	 <b>Sensor boxes SRBE</b>
<b>Measured variable</b>			
<b>Operating voltage range AC</b>		0 ... 250 V	0 ... 250 V
<b>Operating voltage range DC</b>	6 ... 60 V	0 ... 175 V	0 ... 60 V
<b>Electrical connection</b>	Screw terminal, plug M12, A-coded	Screw terminal, 10-pin	Screw terminal, 10-pin, 14-pin
<b>Type of mounting</b>		On flange to ISO 5211, with mounting bracket	On flange to ISO 5211, with mounting bracket
<b>New</b>	• Additional versions	• New series	• New series
<b>Quick ordering of selected basic designs</b>		★	
<b>Description</b>	<ul style="list-style-type: none"> <li>• Compact housing with M12 plug connection</li> <li>• Direct mounting on quarter turn actuators to VDI/VDE 3845</li> <li>• AS-Interface® version with extended addressing options</li> <li>• Intrinsically safe version to ATEX and SIL 2 to IEC 61508</li> </ul>	<ul style="list-style-type: none"> <li>• Pre-assembled mounting adapter for ease of installation</li> <li>• Trip cams can be set easily without additional tools</li> <li>• Sturdy, corrosion-resistant design, ideal for use in harsh operating conditions</li> <li>• Clearly visible 3D position indicator allows rapid detection of the current position of the quarter turn actuator</li> </ul>	<ul style="list-style-type: none"> <li>• Trip cams can be set easily without additional tools</li> <li>• Sturdy, corrosion-resistant design, ideal for use in harsh operating conditions</li> <li>• Clearly visible 3D position indicator allows rapid detection of the current position of the quarter turn actuator</li> </ul>
<b>online:</b> →	<a href="#">srbg</a>	<a href="#">srbc</a>	<a href="#">srbe</a>

## Sensor boxes

	 <b>Limit switch attachments</b> <b>SRAP</b>	 <b>Limit switch attachments</b> <b>DAPZ</b>
<b>Measured variable</b>	Rotation angle	
<b>Operating voltage range AC</b>		4 ... 250 V
<b>Operating voltage range DC</b>	15 ... 30 V	4 ... 250 V
<b>Electrical connection</b>	Screw terminal, 9-pin, plug-in	Screw terminal
<b>Type of mounting</b>		
<b>Description</b>	<ul style="list-style-type: none"> <li>• Based on standard VDI/VDE 3845 (NAMUR)</li> <li>• Analogue</li> <li>• For monitoring the position of quarter turn actuators</li> <li>• Sensors based on 2D Hall technology</li> </ul>	<ul style="list-style-type: none"> <li>• Square or round design</li> <li>• Drive interface to standard VDI/VDE 3845 (NAMUR)</li> <li>• With pneumatic, electric or inductive sensing</li> </ul>
<b>online: →</b>	<a href="#">srp</a>	<a href="#">dapz</a>

## Electromechanical switches

	 <b>Micro switches</b> <b>S-3, SR-3</b>
<b>Operating voltage range AC</b>	12 ... 250 V
<b>Operating voltage range DC</b>	12 ... 250 V
<b>Description</b>	<ul style="list-style-type: none"> <li>• Electric limit switch</li> <li>• N/C contact, N/O contact, changeover switch</li> <li>• Actuator attachments: roller lever type AR, roller lever with idle return type AL, whisker attachment type AF</li> </ul>
<b>online: →</b>	<a href="#">s-3</a>

## Vision sensors



**Code readers, object sensors**  
**SBSI-B, SBSI-Q**

<b>Sensor resolution</b>	1280 x 1024 Pixel (SXGA), 736 x 480 Pixel WideVGA
<b>Working distance</b>	6 mm – infinite, 30 mm – infinite
<b>Field of vision</b>	min. 16 mm x 13 mm, min. 5 x 4 mm, min. 8 x 6 mm
<b>Frame rate (full image)</b>	40 fps, 50 fps
<b>Max.no. of inspection programs</b>	8, 255
<b>Description</b>	<ul style="list-style-type: none"> <li>• Vision sensor with integrated lighting/lens</li> <li>• Enables reading of 1D/2D codes or quality inspection of parts</li> <li>• Intuitive software for simple parameter setting</li> <li>• All-in-one device with integrated lens, lighting, evaluation and communication</li> </ul>
<b>online: →</b>	<a href="#">sbsi</a>

## Compact vision systems





**Compact vision systems**  
**SBOA-M**



**Compact vision systems**  
**SBOC-M**

<b>Sensor resolution</b>	640 x 480 Pixel (VGA)	640 x 480 Pixel VGA
<b>Working distance</b>	Depends on the lens chosen	Depends on the lens chosen
<b>Field of vision</b>	Depends on the lens chosen	Depends on the lens chosen
<b>Frame rate (full image)</b>	27 ... 241 fps	241 fps
<b>Exposure time</b>	1 ... 1000000 µs	1 ... 1000000 µs
<b>Description</b>	<ul style="list-style-type: none"> <li>• Systainer with compact vision system SBOC-M</li> </ul>	<ul style="list-style-type: none"> <li>• High-speed camera for diagnostics and commissioning as well as for function monitoring of fast motion sequences</li> <li>• Recording and storage electronics integrated in the camera</li> <li>• For standard lens with C mount connection</li> <li>• Can be networked via Ethernet</li> <li>• Compact dimensions, low weight</li> </ul>
<b>online: →</b>	<a href="#">sbox</a>	<a href="#">sbox</a>

## Compact vision systems



	 <b>Compact vision systems SBOC-Q</b>	 <b>Compact vision systems SBOI-Q</b>	 <b>Checkbox Compact CHB-C-N</b>
<b>Sensor resolution</b>	752 x 480 Pixel WideVGA	752 x 480 Pixel WideVGA	2048 pixels/line
<b>Working distance</b>	Depends on the lens chosen	20 ... 550 mm	
<b>Field of vision</b>	Depends on the lens chosen	7,9 x 5,5 mm - 195 x 125 mm	
<b>Frame rate (full image)</b>	60 fps	60 fps	
<b>Exposure time</b>	18 ... 200000 µs	18 ... 200000 µs	
<b>New</b>			<ul style="list-style-type: none"> <li>• New series</li> </ul>
<b>Description</b>	<ul style="list-style-type: none"> <li>• Intelligent field-based camera</li> <li>• For 2D quality inspection, position and rotary orientation sensing, reading of 1D and 2D codes, reading of optical characters (OCR)</li> <li>• Integrated full PLC (CODESYS)</li> <li>• Ethernet and CAN for communicating with higher-order controllers</li> </ul>	<ul style="list-style-type: none"> <li>• Intelligent field-based camera</li> <li>• For 2D quality inspection, position and rotary orientation sensing, reading of 1D and 2D codes, reading of optical characters (OCR)</li> <li>• Integrated full PLC (CODESYS)</li> <li>• Ethernet and CAN for communicating with higher-order controllers</li> </ul>	<ul style="list-style-type: none"> <li>• Intelligent line-scan camera</li> <li>• For orientation recognition and quality inspection of small moving parts</li> <li>• Encoder connection</li> <li>• Teach-in function</li> </ul>
<b>online: →</b>	<a href="#">sbox</a>	<a href="#">sbox</a>	<a href="#">chb-c</a>

New

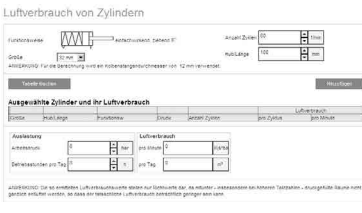
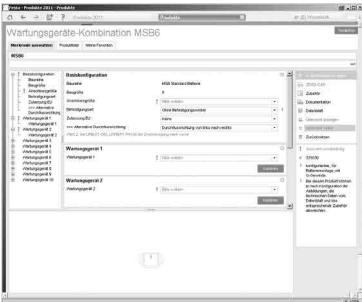

Software tool

<p><b>Air consumption</b></p>		<p>Calculate your system's air consumption quickly and conveniently. Simply enter all the drives and tubing, set the cycle times and working pressure and the air consumption per minute and per day will be calculated for you. It includes a feature for exporting the input table together with the result directly to Excel.</p> <p>This tool can be found</p> <ul style="list-style-type: none"> <li>• either in the electronic catalogue by clicking on the blue button "Engineering"</li> <li>• or on the DVD under Engineering Tools.</li> </ul>
<p><b>Configurator</b></p>		<p>Design a product with numerous features reliably and quickly with the help of the configurator.</p> <p>Select all the required product features step-by-step. The use of logic checks ensures that only correct configurations are available for selection. A dynamic graphic generated on the basis of the configuration provides visual assistance in selecting the correct product features.</p> <p>The configurator is part of the electronic catalogue and is not available as a separate software program.</p>



Service unit combinations: MS series

	 <p><b>Service unit combinations MSE6 -E2M</b></p>	 <p><b>Service unit combinations MSB4, MSB6, MSB9</b></p>
<b>Pneumatic connection 1</b>	G1/2	G1, G1 1/2, G1 1/4, G1/2, G1/4, G1/8, G3/4, NPT1 1/2-11 1/2, NPT1 1/4-11 1/2, NPT1-11 1/2, NPT1/2-14, NPT3/4-14
<b>Standard nominal flow rate</b>	In main flow direction 1 -> 24500 l/min	750 ... 18000 l/min
<b>Flow measuring range final value</b>	5000 l/min	
<b>Pressure regulation range</b>		0.5 ... 16 bar
<b>Operating pressure</b>	4 ... 10 bar	0 ... 20 bar
<b>Grade of filtration</b>		0.01 ... 40 µm
<b>Fieldbus interface</b>	2x socket, M12x1, 4-pin, D-coded, 2x RJ45 push-pull socket, AIDA, 2x SCRJ push-pull socket, AIDA, Sub-D socket, 9-pin	
<b>New</b>	<ul style="list-style-type: none"> <li>• Fieldbus interfaces: PROFINET, Ethernet/IP and Modbus TCP/IP</li> </ul>	
<b>Quick ordering of selected basic designs</b>		★
<b>Description</b>	<ul style="list-style-type: none"> <li>• Intelligent pneumatic service unit for optimising the use of compressed air as an energy source</li> <li>• Function: energy saving (2/2-way function DE, V24)</li> <li>• Equipped with measuring, control and diagnostic functions</li> <li>• Identification of production downtime and leakages</li> <li>• Use as process monitoring module</li> <li>• Electrical actuation via bus node</li> <li>• Size 6</li> </ul>	<ul style="list-style-type: none"> <li>• Combination of filter regulator, filter, lubricator, on-off valve, soft-start valve</li> <li>• Size 4, 6, 9</li> </ul>
<b>online:</b> →	<a href="#">mse6</a>	<a href="#">msb4</a>

## Service unit combinations: D series, metal

	 <b>Service unit combinations with lubricator</b> <b>FRC-K</b>	 <b>Service unit combinations without lubricator</b> <b>LFR-K, LFRS-K</b>
<b>Pneumatic connection 1</b>	G1/2, G1/4, G1/8, G3/4, G3/8	G1/2, G1/4, G1/8, G3/4, G3/8
<b>Standard nominal flow rate</b>	530 ... 8200 l/min	575 ... 9400 l/min
<b>Pressure regulation range</b>	0.5 ... 12 bar	0.5 ... 12 bar
<b>Operating pressure</b>	1 ... 16 bar	1 ... 16 bar
<b>Grade of filtration</b>	40 µm	40 µm
<b>Description</b>	<ul style="list-style-type: none"> <li>• Combination of filter regulator, branching module, lubricator, on-off valve, soft-start valve, mounting accessories</li> <li>• Size: mini, midi, maxi</li> </ul>	<ul style="list-style-type: none"> <li>• Combination of filter regulator, branching module, on-off valve, soft-start valve, mounting accessories</li> <li>• Size: mini, midi, maxi</li> </ul>
<b>online: →</b>	<a href="#">frc</a>	<a href="#">lfr</a>

## Service unit combinations: D series, polymer

	 <b>Service unit combinations with lubricator</b> <b>FRC-K</b>	 <b>Service unit combinations without lubricator</b> <b>LFR-DB</b>
<b>Pneumatic connection 1</b>	G1/4	G1/4
<b>Standard nominal flow rate</b>	400 ... 700 l/min	1900 l/min
<b>Pressure regulation range</b>	0.5 ... 7 bar	0.5 ... 7 bar
<b>Operating pressure</b>	1.5 ... 10 bar	1.5 ... 10 bar
<b>Grade of filtration</b>	40 µm	40 µm
<b>Description</b>	<ul style="list-style-type: none"> <li>• Combination of on-off valve, filter regulator, distributor module and lubricator</li> <li>• Size: mini</li> </ul>	<ul style="list-style-type: none"> <li>• Combination of on-off valve, filter regulator and distributor module</li> <li>• Size: mini</li> </ul>
<b>online: →</b>	<a href="#">frc</a>	<a href="#">lfr</a>

## Filter regulators/lubricators: MS series

	 <p><b>Service unit combinations</b> <b>MSB4-FRC, MSB6-FRC</b></p>
<b>Pneumatic connection 1</b>	G1/2, G1/4, G1/8, G3/8
<b>Standard nominal flow rate</b>	850 ... 4800 l/min
<b>Pressure regulation range</b>	0.3 ... 12 bar
<b>Operating pressure</b>	0.8 ... 20 bar
<b>Grade of filtration</b>	5 ... 40 µm
<b>Quick ordering of selected basic designs</b>	★
<b>Description</b>	<ul style="list-style-type: none"> <li>• Filter, regulator and lubricator functions in a single unit</li> <li>• High flow rate and highly efficient in removing contaminants</li> <li>• Good regulation characteristics with minimal pressure hysteresis</li> <li>• Sizes: 4, 6</li> </ul>
<b>online: →</b>	<a href="#">msb4-frc</a>

## Filter regulators/lubricators: D series, metal

	 <p><b>Service units</b> <b>FRC, FRCS</b></p>
<b>Pneumatic connection 1</b>	G1, G1/2, G1/4, G1/8, G3/4, G3/8, M5, M7, QS-4, QS-6
<b>Standard nominal flow rate</b>	80 ... 8700 l/min
<b>Pressure regulation range</b>	0.5 ... 12 bar
<b>Operating pressure</b>	1 ... 16 bar
<b>Grade of filtration</b>	5 ... 40 µm
<b>Description</b>	<ul style="list-style-type: none"> <li>• Filter, regulator and lubricator functions in a single unit</li> <li>• Size: micro, mini, midi, maxi</li> </ul>
<b>online: →</b>	<a href="#">frc</a>

## Filter regulators/lubricators: D series, polymer

	 <p><b>Service units</b> <b>FRC-DB</b></p>
<b>Pneumatic connection 1</b>	G1/4
<b>Standard nominal flow rate</b>	550 ... 650 l/min
<b>Pressure regulation range</b>	0.5 ... 7 bar
<b>Operating pressure</b>	1.5 ... 10 bar
<b>Grade of filtration</b>	5 ... 40 µm
<b>Description</b>	<ul style="list-style-type: none"> <li>• Filter, regulator and lubricator functions in a single unit</li> <li>• With manual or semi-automatic condensate drain</li> <li>• Size: mini</li> </ul>
<b>online: →</b>	<a href="#">frc</a>

## Filter regulators: MS series



**Filter regulators**  
**MS4-LFR, MS6-LFR, MS9-LFR, MS12-LFR**

<b>Pneumatic connection 1</b>	G1/2, G1/4, G1/8, G3/8, Internal
<b>Standard nominal flow rate</b>	850 ... 24000 l/min
<b>Pressure regulation range</b>	0.3 ... 16 bar
<b>Operating pressure</b>	0.8 ... 20 bar
<b>Grade of filtration</b>	5 ... 40 µm
<b>Quick ordering of selected basic designs</b>	★
<b>Description</b>	<ul style="list-style-type: none"> <li>• MS4-LFR, MS6-LFR: directly actuated diaphragm regulator, MS9-LFR: piloted or directly actuated filter-diaphragm regulator, MS12-LFR: piloted diaphragm regulator without internal air consumption</li> <li>• Good regulation characteristics with minimal pressure hysteresis and primary pressure compensation</li> <li>• Good particle and condensate separation</li> <li>• With or without secondary venting</li> <li>• High flow rate</li> <li>• Lockable rotary knob</li> <li>• Return flow option for exhausting from output 2 to input 1 already integrated</li> <li>• Sizes: 4, 6, 9, 12</li> </ul>
<b>online: →</b>	<a href="#">ms4-lfr</a>

## Filter regulators: D series, metal



**Filter regulators**  
**LFR, LFRS**





<b>Pneumatic connection 1</b>	G1, G1/2, G1/4, G1/8, G3/4, G3/8, M5, M7, QS-4, QS-6
<b>Standard nominal flow rate</b>	110 ... 11000 l/min
<b>Pressure regulation range</b>	0.5 ... 12 bar
<b>Operating pressure</b>	1 ... 16 bar
<b>Grade of filtration</b>	5 ... 40 µm
<b>Description</b>	<ul style="list-style-type: none"> <li>• Two pressure gauge connections for different installation options</li> <li>• With manual, semi-automatic or fully automatic condensate drain</li> <li>• Lockable rotary knob</li> <li>• Size: micro, mini, midi, maxi</li> </ul>
<b>online: →</b>	<a href="#">lfr</a>





## Filter regulators: D series, polymer

	
	<b>Filter regulators LFR-DB</b>
<b>Pneumatic connection 1</b>	G1/4
<b>Standard nominal flow rate</b>	1000 ... 1200 l/min
<b>Pressure regulation range</b>	0.5 ... 7 bar
<b>Operating pressure</b>	1.5 ... 10 bar
<b>Grade of filtration</b>	5 ... 40 µm
<b>Description</b>	<ul style="list-style-type: none"> <li>• With manual or semi-automatic condensate drain</li> <li>• Size: mini</li> </ul>
<b>online: →</b>	<a href="#">lfr</a>



## Filters: MS series

				
	<b>Filters MS4-LF, MS6-LF, MS9-LF, MS12-LF</b>	<b>Activated carbon filters MS4-LFX, MS6-LFX, MS9-LFX, MS12-LFX</b>	<b>Fine filters MS4-LFM-B, MS6-LFM-B, MS9-LFM-B, MS12-LFM-B</b>	<b>Micro filters MS4-LFM-A, MS6-LFM-A, MS9-LFM-A, MS12-LFM-A</b>
<b>Pneumatic connection 1</b>	G1/2, G1/4, G1/8, G3/8, In- ternal	G1/2, G1/4, G1/8, G3/8	G1, G1/2, G1/4, G1/8, G3/4, G3/8, Manifold module	G1, G1/2, G1/4, G1/8, G3/4, G3/8, Manifold module
<b>Standard nominal flow rate</b>	1000 ... 16000 l/min	360 ... 2500 l/min	54 ... 10000 l/min	54 ... 7800 l/min
<b>Operating pressure</b>	0 ... 20 bar	0 ... 20 bar	0 ... 20 bar	0 ... 20 bar
<b>Grade of filtration</b>	5 ... 40 µm	0.01 ... 1 µm	0.01 ... 1 µm	0.01 ... 1 µm
<b>Description</b>	<ul style="list-style-type: none"> <li>• Good particle and condensate separation</li> <li>• High flow rate with minimal pressure drop</li> <li>• Available with manual, semi-automatic, fully automatic or fully automatic, electrically actuated condensate drain</li> <li>• Sizes: 4, 6, 9, 12</li> </ul>	<ul style="list-style-type: none"> <li>• Removal of gaseous oil particles from compressed air using activated carbon</li> <li>• Air quality class at the output [1.4.1] to ISO 8573-1</li> <li>• Eliminates odours and vapours</li> <li>• Residual oil content = 0.003 mg/m<sup>3</sup></li> <li>• Sizes: 4, 6, 9, 12</li> </ul>	<ul style="list-style-type: none"> <li>• High-efficiency filter for exceptionally clean compressed air</li> <li>• Removal of oil aerosols from compressed air</li> <li>• Available with differential pressure indicator for indication of contamination</li> <li>• Available with electronic filter contamination indicator</li> <li>• Sizes: 4, 6, 9, 12</li> </ul>	<ul style="list-style-type: none"> <li>• High-efficiency filter for exceptionally clean compressed air</li> <li>• Removal of oil aerosols from compressed air</li> <li>• Available with differential pressure indicator for indication of contamination</li> <li>• Available with electronic filter contamination indicator</li> <li>• Sizes: 4, 6, 9, 12</li> </ul>
<b>online: →</b>	<a href="#">ms4-lf</a>	<a href="#">ms4-lfx</a>	<a href="#">ms4-lfm-b</a>	<a href="#">ms4-lfm-a</a>



## Filters: D series, metal

	 <b>Filters LF</b>	 <b>Fine filters LFMB</b>	 <b>Micro filters LFMA</b>
<b>Pneumatic connection 1</b>	G1, G1/2, G1/4, G1/8, G3/4, G3/8, M5, M7, QS-4, QS-6, Sub-base	G1, G1/2, G1/4, G1/8, G3/4, G3/8, Sub-base	G1, G1/2, G1/4, G1/8, G3/4, G3/8, Sub-base
<b>Standard nominal flow rate</b>	170 ... 5300 l/min	125 ... 2780 l/min	80 ... 2200 l/min
<b>Operating pressure</b>	0 ... 16 bar	1 ... 16 bar	1 ... 16 bar
<b>Grade of filtration</b>	5 ... 40 µm	1 µm	0.01 µm
<b>Description</b>	<ul style="list-style-type: none"> <li>• Good particle and condensate separation</li> <li>• With manual or fully automatic condensate drain</li> <li>• Size: micro, mini, midi, maxi</li> </ul>	<ul style="list-style-type: none"> <li>• High-efficiency filter for exceptionally clean compressed air</li> <li>• Removal of oil aerosols from compressed air</li> <li>• Version with differential pressure indicator for visual indication of filter contamination</li> <li>• Size: mini, midi, maxi</li> </ul>	<ul style="list-style-type: none"> <li>• High-efficiency filter for exceptionally clean compressed air</li> <li>• Removal of oil aerosols from compressed air</li> <li>• Version with differential pressure indicator for visual indication of filter contamination</li> <li>• Size: mini, midi, maxi</li> </ul>
<b>online: →</b>	<a href="#">lf</a>	<a href="#">lfmb</a>	<a href="#">lfma</a>

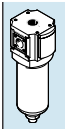

## Filters: D series, metal

	 <b>Filter combination LFMB</b>	 <b>Activated carbon filters LFX</b>
<b>Pneumatic connection 1</b>	G1, G1/2, G1/4, G1/8, G3/4, G3/8	G1, G1/2, G1/4, G1/8, G3/4, G3/8, Connecting plate, manifold module
<b>Standard nominal flow rate</b>	125 ... 600 l/min	360 ... 1100 l/min
<b>Operating pressure</b>	1 ... 16 bar	0 ... 16 bar
<b>Grade of filtration</b>	0.01 µm	
<b>Description</b>	<ul style="list-style-type: none"> <li>• High-efficiency filter for exceptionally clean compressed air</li> <li>• Fully assembled filter combination, comprising LFMB and LFMA</li> <li>• Version with differential pressure indicator for visual indication of filter contamination</li> <li>• Size: mini, midi, maxi</li> </ul>	<ul style="list-style-type: none"> <li>• Removal of gaseous oil particles from compressed air using activated carbon</li> <li>• Air quality class at the output [1.4.1] to ISO 8573-1</li> <li>• Eliminates odours and vapours</li> <li>• Residual oil content = 0.003 mg/m<sup>3</sup></li> <li>• Size: mini, midi, maxi</li> </ul>
<b>online: →</b>	<a href="#">lfmba</a>	<a href="#">lfx</a>



## Filters: individual devices

	 <b>Filter silencers</b> <b>LFU</b>	 <b>Micro filters</b> <b>PFML</b>
<b>Size</b>	G1/4, G3/8, G1/2, G1	90, 186
<b>Grade of filtration</b>	1 µm	0.01 µm
<b>Operating pressure</b>	0 ... 16 bar	0 ... 50 bar
<b>Flow rate with respect to atmosphere</b>	4000 ... 12500 l/min	
<b>Noise reduction</b>	Reduction by 40 dB	
<b>New</b>		 <ul style="list-style-type: none"> <li>• New series</li> </ul>
<b>Description</b>	<ul style="list-style-type: none"> <li>• Removes up to 99.99% of oil and other contaminants from exhaust air</li> <li>• Manual rotary condensate drain</li> <li>• Reduced exhaust noise regardless of frequency</li> </ul>	<ul style="list-style-type: none"> <li>• For high-pressure applications</li> <li>• See supplementary information on food-safe materials at <a href="http://www.festo.com/sp">www.festo.com/sp</a> &gt; Certificates</li> </ul>
<b>online:</b> →	<a href="#">lfu</a>	<a href="#">pfml</a>



## Regulators: MS series

	 <b>Pressure regulators</b> <b>MS4-LR, MS6-LR, MS9-LR</b>	 <b>Pressure regulators</b> <b>MS12-LR</b>	 <b>Pressure regulators</b> <b>MS4-LRB, MS6-LRB</b>
<b>Pneumatic connection 1</b>	G1/2, G1/4, G1/8, G3/8	Sub-base	G1/2, G1/4
<b>Standard nominal flow rate</b>	1000 ... 30000 l/min	12000 ... 22000 l/min	300 ... 7300 l/min
<b>Pressure regulation range</b>	0.3 ... 16 bar	0.15 ... 16 bar	0.3 ... 16 bar
<b>Operating pressure</b>	0.8 ... 20 bar	0.8 ... 21 bar	0.8 ... 20 bar
<b>Max. pressure hysteresis</b>	0.25 ... 0.4 bar	0.04 ... 0.4 bar	0.25 bar
<b>Quick ordering of selected basic designs</b>	★		
<b>Description</b>	<ul style="list-style-type: none"> <li>• High flow rate with minimal pressure drop</li> <li>• Good regulation characteristics with minimal pressure hysteresis and primary pressure compensation</li> <li>• With or without secondary venting</li> <li>• Lockable rotary knob</li> <li>• Optional pressure sensor and rotary knob pressure gauge</li> <li>• Size 4, 6, 9</li> </ul>	<ul style="list-style-type: none"> <li>• High flow rate with minimal pressure drop</li> <li>• Good regulation characteristics with minimal pressure hysteresis and primary pressure compensation</li> <li>• With secondary venting</li> <li>• Lockable rotary knob</li> <li>• MS12-LR-...-PO: pneumatically actuated (pressure range determined by pilot regulator)</li> <li>• MS12-LR-...-PE6: solenoid actuated (pilot control by proportional pressure regulator)</li> <li>• Size: 12</li> </ul>	<ul style="list-style-type: none"> <li>• To build up a regulator manifold with through air supply for pressure ranges that can be adjusted independently of another</li> <li>• Good regulation characteristics with minimal pressure hysteresis and primary pressure compensation</li> <li>• Lockable rotary knob</li> <li>• With or without secondary venting</li> <li>• Integrated return flow option for exhausting from output 2 to input 1</li> <li>• Optional pressure sensor and rotary knob pressure gauge</li> <li>• Sizes: 4, 6</li> </ul>
<b>online:</b> →	<a href="#">ms4-lr</a>	<a href="#">ms12-lr</a>	<a href="#">ms4-lrb</a>



## Regulators: MS series

	 <b>Precision pressure regulators</b> <b>MS6-LRP, MS6-LRPB</b>	 <b>Electric pressure regulators</b> <b>MS6-LRE</b>
<b>Pneumatic connection 1</b>	G1/2, G1/4, G3/8	G1/2, G1/4, G3/8
<b>Standard nominal flow rate</b>	800 ... 5000 l/min	2200 ... 7500 l/min
<b>Pressure regulation range</b>	0.05 ... 12 bar	0.3 ... 16 bar
<b>Operating pressure</b>	1 ... 14 bar	0.8 ... 20 bar
<b>Max. pressure hysteresis</b>	0.02 bar	0.25 bar
<b>Description</b>	<ul style="list-style-type: none"> <li>• As individual device and for manifold assembly</li> <li>• Manifold assembly with through air supply</li> <li>• Good regulation characteristics with minimal pressure hysteresis and primary pressure compensation</li> <li>• High secondary venting</li> <li>• Lockable rotary knob</li> <li>• Available with pressure sensor with display</li> <li>• Size: 6</li> </ul>	<ul style="list-style-type: none"> <li>• With integrated electric drive unit for remotely setting the output pressure</li> <li>• Constant output pressure even in the event of a power failure thanks to the fail-safe function</li> <li>• Available with control unit with display</li> <li>• Optional pressure sensor</li> <li>• With or without secondary venting</li> <li>• Size: 6</li> </ul>
<b>online: →</b>	<a href="#">ms6-lrp</a>	<a href="#">ms6-lre</a>



## Regulators: D series, metal

	 <b>Pressure regulators</b> <b>LR, LRS</b>	 <b>Pressure regulators</b> <b>LRB, LRBS</b>	 <b>Pressure regulator combinations</b> <b>LRB-K</b>
<b>Pneumatic connection 1</b>	G1, G1/2, G1/4, G1/8, G3/4, G3/8, M5, M7, QS-4, QS-6	Sub-base	G1/2, G1/4, G3/8
<b>Standard nominal flow rate</b>	120 ... 12500 l/min	1600 ... 3800 l/min	1600 ... 3800 l/min
<b>Pressure regulation range</b>	0.5 ... 12 bar	0.5 ... 12 bar	0.5 ... 12 bar
<b>Operating pressure</b>	0 ... 16 bar	1 ... 16 bar	1 ... 16 bar
<b>Max. pressure hysteresis</b>	0.2 ... 0.4 bar	0.2 bar	0.2 bar
<b>Description</b>	<ul style="list-style-type: none"> <li>• Lockable design</li> <li>• Two pressure gauge connections for different installation options</li> <li>• Micro, mini, midi size: directly actuated diaphragm regulator</li> <li>• Maxi size: piloted piston regulator, diaphragm regulator LRS-DI</li> <li>• Optional return flow option for venting from output 2 to input 1</li> <li>• Available with pressure gauge</li> <li>• Size: micro, mini, midi, maxi</li> </ul>	<ul style="list-style-type: none"> <li>• To build up a regulator manifold with through air supply for pressure ranges that can be adjusted independently of another</li> <li>• Directly actuated diaphragm regulator</li> <li>• Settings secured via detent on rotary knob and push-in adjustment lock</li> <li>• Lockable design</li> <li>• Without pressure gauge</li> <li>• Size: mini, midi</li> </ul>	<ul style="list-style-type: none"> <li>• Regulator manifold with through air supply for pressure ranges that can be adjusted independently of one another</li> <li>• Directly actuated diaphragm regulator</li> <li>• Settings secured via detent on rotary knob and push-in adjustment lock</li> <li>• Without pressure gauge</li> <li>• Size: mini, midi</li> </ul>
<b>online: →</b>	<a href="#">lr</a>	<a href="#">lrb</a>	<a href="#">lrb</a>

## Regulators: D series, polymer

	 <b>Pressure regulators</b> <b>LR-DB</b>	 <b>Pressure regulator combinations</b> <b>LRB-DB</b>
<b>Pneumatic connection 1</b>	G1/4	G1/2
<b>Standard nominal flow rate</b>	≥1300 l/min	≥1000 l/min
<b>Pressure regulation range</b>	0.5 ... 7 bar	0.5 ... 7 bar
<b>Operating pressure</b>	1.5 ... 10 bar	1.5 ... 10 bar
<b>Max. pressure hysteresis</b>	0.5 bar	0.5 bar
<b>Description</b>	<ul style="list-style-type: none"> <li>• Setting values are secured by locking the rotary knob</li> <li>• Available with pressure gauge</li> <li>• Size: mini</li> </ul>	<ul style="list-style-type: none"> <li>• Regulator manifold with through air supply for pressure ranges that can be adjusted independently of one another</li> <li>• Setting values are secured by locking the rotary knob</li> <li>• Without pressure gauge</li> <li>• Size: mini</li> </ul>
<b>online: →</b>	<a href="#">lr-db</a>	<a href="#">lrb-db</a>

## Regulators: individual devices

	 <b>Precision pressure regulators</b> <b>LRP, LRPS</b>	 <b>Pressure regulators</b> <b>PREL</b>
<b>Pneumatic connection 1</b>	G1/4, G1/8, For connecting plate diameter 7 mm	G1
<b>Standard nominal flow rate</b>	240 ... 2300 l/min	
<b>Pressure regulation range</b>	0.05 ... 10 bar	0.2 ... 40 bar
<b>Operating pressure</b>	1 ... 12 bar	0 ... 50 bar
<b>Max. pressure hysteresis</b>	0.02 bar	0.1 bar
<b>New</b>	<ul style="list-style-type: none"> <li>• Additional size</li> </ul>	<ul style="list-style-type: none"> <li>• New series</li> </ul>
<b>Description</b>	<ul style="list-style-type: none"> <li>• Lockable design</li> <li>• Good regulation characteristics with minimal pressure hysteresis and primary pressure compensation</li> <li>• High secondary venting</li> </ul>	<ul style="list-style-type: none"> <li>• For high-pressure applications</li> <li>• See supplementary information on food-safe materials at <a href="http://www.festo.com/sp">www.festo.com/sp</a> &gt; Certificates</li> <li>• Size: 186 mm</li> </ul>
<b>online: →</b>	<a href="#">lrp</a>	<a href="#">prel</a>

## Lubricators: MS series



**Lubricators**  
**MS4-LOE, MS6-LOE, MS9-LOE, MS12-LOE**

<b>Pneumatic connection 1</b>	G1/2, G1/4, G1/8, G3/8, Internal
<b>Standard nominal flow rate</b>	1100 ... 22000 l/min
<b>Operating pressure</b>	1 ... 16 bar
<b>Min. flow rate for lubricator operation</b>	40 ... 400 l/min
<b>Description</b>	<ul style="list-style-type: none"> <li>• Proportional lubricator with precision oil metering</li> <li>• Quick and easy top-up even under pressure</li> <li>• Oil capacity 30 ... 1500 cm<sup>3</sup></li> <li>• Sizes: 4, 6, 9, 12</li> </ul>
<b>online: →</b>	<a href="#">ms4-loe</a>



## Lubricators: D series, metal





**Lubricators**  
**LOE**

<b>Pneumatic connection 1</b>	G1, G1/2, G1/4, G1/8, G3/4, G3/8, M5, M7, QS-4, QS-6
<b>Standard nominal flow rate</b>	160 ... 9000 l/min
<b>Operating pressure</b>	0 ... 16 bar
<b>Min. flow rate for lubricator operation</b>	3 ... 10 l/min
<b>Description</b>	<ul style="list-style-type: none"> <li>• Proportional lubricator with precision oil metering</li> <li>• Quick and easy top-up even under pressure</li> <li>• Oil capacity 6.5 ... 190 cm<sup>3</sup></li> <li>• Size: micro, mini, midi, maxi</li> </ul>
<b>online: →</b>	<a href="#">loe</a>





## On-off and soft-start valves: MS series

	 <b>Soft-start/quick exhaust valves</b> MS6-SV-E, MS6-SV-D	 <b>Soft-start/quick exhaust valves</b> MS6-SV-C, MS9-SV-C	 <b>On-off valves</b> MS4-EM1, MS6-EM1, MS9-EM, MS12-EM
<b>Pneumatic connection 1</b>	G1/2	G1/2	G1/2, G1/4, G1/8, G3/8, Manifold module
<b>Standard nominal flow rate</b>	4300 ... 5700 l/min	4300 ... 16550 l/min	1200 ... 32000 l/min
<b>Operating pressure</b>	3 ... 10 bar	3 ... 16 bar	0 ... 20 bar
<b>Type of control</b>	Electric	Electric	Manual
<b>Quick ordering of selected basic designs</b>		★	★
<b>Description</b>	<ul style="list-style-type: none"> <li>Reliable 2-channel exhausting with self-monitoring up to Performance Level e and category 4 to EN ISO 13849-1</li> <li>For reducing pressure quickly and reliably and for building up pressure gradually</li> <li>SIL 3</li> <li>Adjustable pressure build-up time</li> <li>Available with silencer</li> <li>Supply voltage 24 V DC</li> <li>Size: 6</li> </ul>	<ul style="list-style-type: none"> <li>Single-channel exhausting up to Performance Level c and category 1 to EN ISO 13849-1</li> <li>For reducing pressure quickly and reliably and for building up pressure gradually</li> <li>Adjustable pressure build-up time</li> <li>Adjustable switch-through pressure</li> <li>Supply voltage 24 V DC</li> <li>Sizes: 6, 9</li> </ul>	<ul style="list-style-type: none"> <li>Manual 3/2-way valve for pressurising and venting pneumatic installations</li> <li>A silencer can be attached or the exhaust air can be ducted at port 3</li> <li>Switching position is immediately recognisable</li> <li>Optionally with pressure gauge and pressure sensor</li> <li>Sizes: 4, 6, 9, 12</li> </ul>
<b>online: →</b>	<a href="#">ms6-sv-e</a>	<a href="#">ms6-sv-c</a>	<a href="#">ms4-em1</a>

## On-off and soft-start valves: MS series

	 <b>Soft-start valves</b> MS4-DE, MS6-DE, MS12-DE	 <b>Soft-start valves</b> MS4-DL, MS6-DL, MS12-DL	 <b>On-off valves</b> MS4-EE, MS6-EE, MS9-EE, MS12-EE
<b>Pneumatic connection 1</b>	G1/2, G1/4, G3/8, NPT1/2-14, Manifold module	G1/2, G1/4, G1/8, G3/8, Manifold module	G1/2, G1/4, G1/8, G3/8, Manifold module
<b>Standard nominal flow rate</b>	1000 ... 42000 l/min	1000 ... 42000 l/min	1000 ... 32000 l/min
<b>Operating pressure</b>	3 ... 18 bar	2 ... 20 bar	3 ... 18 bar
<b>Type of control</b>	Electric	Pneumatic	Electric
<b>Quick ordering of selected basic designs</b>		★	★
<b>Description</b>	<ul style="list-style-type: none"> <li>2/2-way valve for slowly pressurising pneumatic systems with electrically switchable pressure switchover point</li> <li>Supply voltage 24 V DC, 110, 230 V AC</li> <li>Switchable pressure switching point</li> <li>For advancing the drives slowly and reliably into the initial position</li> <li>For avoiding sudden and unexpected movements</li> <li>Adjustable pressure build-up time</li> <li>Sizes 4, 6, 12</li> </ul>	<ul style="list-style-type: none"> <li>2/2-way valve for slowly pressurising pneumatic installations (for use with on-off valves EM1 and EE)</li> <li>For building up pressure gradually</li> <li>Adjustable pressure build-up time</li> <li>Sizes 4, 6, 12</li> </ul>	<ul style="list-style-type: none"> <li>Electric 3/2-way valve for pressurising and exhausting pneumatic systems</li> <li>A silencer can be attached or the exhaust air can be ducted at port 3</li> <li>Supply voltage 24 V DC, 110, 230 V AC</li> <li>Optionally with pressure gauge and pressure sensor</li> <li>With solenoid coil, without plug socket</li> <li>Sizes: 4, 6, 9, 12</li> </ul>
<b>online: →</b>	<a href="#">ms4-de</a>	<a href="#">ms4-dl</a>	<a href="#">ms4-ee</a>

## On-off and soft-start valves: D series, metal

	 <b>On-off valves HE</b>	 <b>On-off valves HEE</b>	 <b>On/off valves HEP</b>	 <b>Soft-start valves HEL</b>
<b>Pneumatic connection 1</b>	G1, G1/2, G1/4, G1/8, G3/4, G3/8	G1, G1/2, G1/4, G1/8, G3/4, G3/8	G1, G1/2, G1/4, G1/8, G3/4, G3/8	G1, G1/2, G1/4, G1/8, G3/4, G3/8
<b>Standard nominal flow rate</b>	1000 ... 10000 l/min	1000 ... 6500 l/min	1000 ... 6500 l/min	1000 ... 6500 l/min
<b>Operating pressure</b>	0 ... 16 bar	2.5 ... 16 bar	0 ... 16 bar	3 ... 16 bar
<b>Type of control</b>	Manual	Electric	Pneumatic	Pneumatic
<b>Description</b>	<ul style="list-style-type: none"> <li>Manual 3/2-way valve for pressurising and venting pneumatic installations</li> <li>A silencer can be attached or the exhaust air can be ducted at port 3</li> <li>The switching position is immediately recognisable</li> <li>Size: mini, midi, maxi</li> </ul>	<ul style="list-style-type: none"> <li>Electric 3/2-way valve for pressurising and venting pneumatic installations</li> <li>A silencer can be attached or the exhaust air can be ducted at port 3</li> <li>With solenoid coil, without plug socket</li> <li>Solenoid actuator can be repositioned by 4x 90°</li> <li>Detenting and non-detenting manual override</li> <li>Supply voltage 24 V DC, 110, 230 V AC</li> <li>Size: mini, midi, maxi</li> </ul>	<ul style="list-style-type: none"> <li>Pneumatic 3/2-way valve for pressurising and exhausting pneumatic installations</li> <li>Especially suitable for applications requiring explosion protection</li> <li>Size: mini, midi, maxi</li> </ul>	<ul style="list-style-type: none"> <li>2/2-way valve for slowly pressurising pneumatic systems (for use with on-off valves HE and HEE)</li> <li>For building up pressure gradually</li> <li>Adjustable pressure build-up time</li> <li>Size: mini, midi, maxi</li> </ul>
<b>online:</b> →	<a href="#">he</a>	<a href="#">hee</a>	<a href="#">hep</a>	<a href="#">hel</a>

## On-off and soft-start valves: D series, polymer

	 <b>On-off valves HE-DB</b>
<b>Pneumatic connection 1</b>	G1/4
<b>Standard nominal flow rate</b>	2300 l/min
<b>Operating pressure</b>	0 ... 10 bar
<b>Type of control</b>	Manual
<b>New</b>	<ul style="list-style-type: none"> <li>New series</li> </ul>
<b>Description</b>	<ul style="list-style-type: none"> <li>3/2-way manual on-off valve</li> <li>Switching position is immediately recognisable</li> <li>Commercially available padlock for security</li> </ul>
<b>online:</b> →	<a href="#">he-db</a>

New

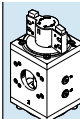

## On-off and soft-start valves: individual devices

	 <b>Shut-off valves</b> <b>HE-LO</b>	 <b>On-off valves</b> <b>PVEL</b>
<b>Pneumatic connection 1</b>	G1, G1/2, G3/4, G3/8	With SAE flange
<b>Standard nominal flow rate</b>	5200 ... 10000 l/min	
<b>Operating pressure</b>	1 ... 10 bar	0 ... 50 bar
<b>Type of control</b>	Manual	Manual, pneumatic
<b>New</b>		<ul style="list-style-type: none"> <li>• New series</li> </ul>
<b>Description</b>	<ul style="list-style-type: none"> <li>• For shutting off the compressed air supply whilst simultaneously venting systems powered by compressed air</li> <li>• Can be locked in the closed position</li> <li>• Screwed into piping, through-holes for wall mounting</li> <li>• To OSHA 29 CFR 147</li> </ul>	<ul style="list-style-type: none"> <li>• For high-pressure applications</li> <li>• See supplementary information on food-safe materials at <a href="http://www.festo.com/sp">www.festo.com/sp</a> &gt; Certificates</li> <li>• Size: 124 mm</li> </ul>
<b>online: →</b>	<a href="#">he-lo</a>	<a href="#">pvel</a>

## Air dryers: MS series

	 <b>Membrane air dryers</b> <b>MS4-LDM1, MS6-LDM1</b>
<b>Pneumatic connection 1</b>	G1/4, G1/2, G3/8, G3/4
<b>Standard nominal flow rate</b>	50 ... 400 l/min
<b>Operating pressure</b>	3 ... 12.5 bar
<b>Pressure dew point reduction</b>	20 K
<b>Description</b>	<ul style="list-style-type: none"> <li>• Final dryer with excellent operational reliability</li> <li>• Suitable for use as an individual device or for integration into existing service unit combinations</li> <li>• Flow rate-dependent dew point reduction</li> <li>• Wear-free function requiring no external energy</li> <li>• Sizes: 4, 6</li> </ul>
<b>online: →</b>	<a href="#">ms4-ldm1</a>



## Air dryers: D series, metal

	 <p><b>Membrane air dryers</b> <b>LDM1</b></p>
<b>Pneumatic connection 1</b>	G1, G1/2, G3/4
<b>Standard nominal flow rate</b>	300 ... 1000 l/min
<b>Operating pressure</b>	3 ... 12.5 bar
<b>Pressure dew point reduction</b>	17 ... 20 K
<b>Description</b>	<ul style="list-style-type: none"> <li>• Final dryer with excellent operational reliability</li> <li>• Suitable for use as an individual device or for integration into existing service unit combinations</li> <li>• Flow rate-dependent dew point reduction</li> <li>• Wear-free function requiring no external energy</li> <li>• Individual device with or without connecting plates, for service unit combination</li> <li>• Size: maxi</li> </ul>
<b>online: →</b>	<a href="#">ldm1</a>



## Air dryers: individual devices

	 <p><b>Adsorption dryer</b> <b>PDAD</b></p>
<b>Pneumatic connection 1</b>	G1/2, G3/8
<b>Supply pressure 1</b>	4 ... 16 bar
<b>Pressure dew point</b>	-40 °C
<b>Description</b>	<ul style="list-style-type: none"> <li>• Ideal for decentralised compressed air drying</li> <li>• Integrated filtering of oil and particulates</li> <li>• Defined pressure dew point</li> <li>• Low purge air consumption</li> </ul>
<b>online: →</b>	<a href="#">pdad</a>

## Compressed air distribution units: MS series



	 <b>Branching modules</b> <b>MS4-FRM, MS6-FRM, MS9-FRM, MS12-FRM</b>	 <b>Distributor blocks</b> <b>MS4-FRM-FRZ, MS6-FRM-FRZ</b>
<b>Pneumatic connection 1</b>	G1, G1 1/2, G1 1/4, G1/2, G1/4, G1/8, G3/4, G3/8, NPT1 1/2-11 1/2, NPT1 1/4-11 1/2, NPT1-11 1/2, NPT1/2-14, NPT3/4-14, G1/4, G1/2, G1, G2, NPT1-11 1/2, Manifold module	G1/4, G1/2
<b>Standard nominal flow rate in main flow direction 1-&gt;2</b>	1200 ... 50000 l/min	4050 ... 14600 l/min
<b>Operating pressure</b>	0 ... 20 bar	0 ... 20 bar
<b>Quick ordering of selected basic designs</b>	★	★
<b>Description</b>	<ul style="list-style-type: none"> <li>Optionally with integrated non-return function and pressure switch</li> <li>Outlet at top and bottom</li> <li>Can be used as an intermediate distributor for varying air qualities</li> <li>Available with pressure sensor</li> <li>Sizes: 4, 6, 9, 12</li> </ul>	<ul style="list-style-type: none"> <li>Slim pneumatic distributor</li> <li>Outlet at top and bottom</li> <li>Can be used as an intermediate distributor for varying air qualities</li> <li>Can be used as an adapter between two pressure regulators with large rotary knob with pressure gauge on size MS4</li> <li>Sizes: 4, 6</li> </ul>
<b>online: →</b>	<a href="#">ms*-frm</a>	<a href="#">ms*-frm-frz</a>

## Compressed air distributors: D series, metal

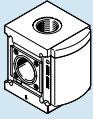
	 <b>Branching modules</b> <b>FRM</b>	 <b>Distributor blocks</b> <b>FRZ</b>
<b>Pneumatic connection 1</b>	G1, G1/2, G1/4, G1/8, G3/4, G3/8	Manifold module
<b>Standard nominal flow rate in main flow direction 1-&gt;2</b>	1100 ... 20000 l/min	
<b>Operating pressure</b>	0 ... 16 bar	
<b>Description</b>	<ul style="list-style-type: none"> <li>Outlet at top and bottom</li> <li>Can be used as an intermediate distributor for varying air qualities</li> <li>Optionally with integrated non-return function and pressure switch</li> <li>Size: mini, midi, maxi</li> </ul>	<ul style="list-style-type: none"> <li>Outlet at top and bottom</li> <li>Can be used as an intermediate distributor for varying air qualities</li> <li>Slim pneumatic distributor</li> <li>Size: micro, mini, midi, maxi</li> </ul>
<b>online: →</b>	<a href="#">frm</a>	<a href="#">frz</a>

	 <p><b>Branching modules PMBL</b></p>	<b>New</b>
<b>Pneumatic connection 3</b>	G1	
<b>Pneumatic connection 4</b>	G1	
<b>Operating pressure</b>	0 ... 50 bar	
<b>New</b>	<ul style="list-style-type: none"> <li>• New series</li> </ul>	
<b>Description</b>	<ul style="list-style-type: none"> <li>• For high-pressure applications</li> <li>• See supplementary information on food-safe materials at <a href="http://www.festo.com/sp">www.festo.com/sp</a> &gt; Certificates</li> <li>• Sizes: 90 mm, 186 mm</li> </ul>	
<b>online: →</b>	<a href="#">pmb1</a>	





## Condensate drain

	 <p><b>Water separators MS6-LWS, MS9-LWS, MS12-LWS</b></p>	 <p><b>Condensate drains, electric PWEA</b></p>	 <p><b>Condensate drains, automatic WA</b></p>
<b>Pneumatic connection</b>		G1/2	M9
<b>Pneumatic connection 1</b>	G1/2, G1/4, G3/8, G1, Sub-base		
<b>Operating pressure</b>	0.8 ... 16 bar	0.8 ... 16 bar	1.5 ... 16 bar
<b>Description</b>	<ul style="list-style-type: none"> <li>• Efficient and maintenance-free water separator</li> <li>• Constantly high condensate separation (99%) up to the maximum flow rate</li> <li>• Available with fully automatic or fully automatic, electrically actuated condensate drain</li> <li>• Sizes: 6, 9, 12</li> </ul>	<ul style="list-style-type: none"> <li>• Fully automatic condensate drain with independent electrical controller</li> <li>• Interface for communicating with master control device</li> <li>• Reliable thanks to non-contacting capacitive sensor</li> <li>• Can be used with service units or simply in piping systems</li> <li>• Ready status and switching status indicated via LEDs and electrical interface</li> </ul>	<ul style="list-style-type: none"> <li>• For attachment to service units and compressed air networks/systems</li> <li>• Automatic emptying after the max.fill level has been reached</li> <li>• Automatic emptying after the operating pressure <math>p &lt; 0.5</math> bar is switched off</li> <li>• Manual actuation during operation is possible</li> </ul>
<b>online: →</b>	<a href="#">ms6-lws</a>	<a href="#">pwea</a>	<a href="#">wa</a>



## Pressure boosters

	 <p><b>Pressure boosters</b> <b>DPA</b></p>
<b>Pneumatic connection 1</b>	G1/2, G1/4, G3/8, QS-10, QS-12, QS-16
<b>Output pressure 2</b>	4 ... 16 bar
<b>Supply pressure 1</b>	2 ... 10 bar
<b>Description</b>	<ul style="list-style-type: none"> <li>• Pneumatic pressure increase up to the double inlet pressure</li> <li>• Optionally as pressure booster/air pressure reservoir combinations</li> <li>• Any mounting position</li> <li>• Short filling times</li> <li>• Long service life</li> <li>• Compact design</li> <li>• Available with sensing option</li> </ul>
<b>online: →</b>	<a href="#">dpa</a>

## Pressure indicators

	 <p><b>Pressure gauges</b> <b>PAGN</b></p>	 <p><b>Pressure gauges</b> <b>MA</b></p>	 <p><b>Flanged pressure gauges</b> <b>FMA</b></p>	 <p><b>Flanged precision pressure gauges, precision pressure gauges</b> <b>FMAP, MAP</b></p>
<b>Type of mounting</b>	In-line installation	In-line installation	Front panel mounting	Front panel mounting, in-line installation
<b>Indicating range [bar]</b>	0 ... 16 bar	0 ... 25 bar	0 ... 16 bar	0 ... 16 bar
<b>Pneumatic connection</b>	Cartridge 10, R1/8	G1/4, G1/8, M5, QS-4, QS-6, QS-8, R1/4, R1/8	G1/4	G1/4, R1/8
<b>Operating pressure</b>	0 ... 16 bar	0 ... 25 bar	0 ... 16 bar	0 ... 16 bar
<b>Measurement accuracy class</b>	1.6, 2.5, 4	1.6, 2.5, 4, 5	1.6, 2.5	1, 1.6
<b>Description</b>	<ul style="list-style-type: none"> <li>• Pneumatic connection via QSP-10</li> <li>• Mounting via retaining clamp</li> <li>• Display units bar, psi</li> </ul>	<ul style="list-style-type: none"> <li>• Designs based on DIN EN 837-1, optionally with red-green range</li> <li>• Pneumatic connection via R, metric or G thread, push-in connector</li> <li>• Display units bar, psi, MPa</li> </ul>	<ul style="list-style-type: none"> <li>• Designs based on EN 837-1</li> <li>• Pneumatic connection via G thread</li> <li>• Display units bar, psi</li> </ul>	<ul style="list-style-type: none"> <li>• Designs based on EN 837-1</li> <li>• Pneumatic connection via R or G thread</li> <li>• Display units bar, psi</li> </ul>
<b>online: →</b>	<a href="#">pagen</a>	<a href="#">ma</a>	<a href="#">fma</a>	<a href="#">fmap</a>

## Pressure indicators

	 <b>Pressure gauge kits DPA</b>	 <b>Vacuum gauges VAM, FVAM</b>	 <b>Pressure gauges PAGL</b>
<b>Type of mounting</b>	With male thread	Front panel mounting, screw-in	In-line installation
<b>Indicating range [bar]</b>		-1 ... 9 bar	0 ... 60 bar
<b>Pneumatic connection</b>	G1/4, G1/8, R1/8	G1/4, G1/8, R1/4, R1/8	G1/4
<b>Operating pressure</b>	10 ... 16 bar	-1 ... 9 bar	0 ... 60 bar
<b>Measurement accuracy class</b>	2.5, 4	2.5	1.6
<b>New</b>			• New series
<b>Description</b>	<ul style="list-style-type: none"> <li>• For pressure booster DPA</li> <li>• For monitoring the inlet and outlet pressure</li> <li>• Pneumatic connection via R or G thread</li> </ul>	<ul style="list-style-type: none"> <li>• Designs based on DIN EN 837-1, available with red-green range</li> <li>• Pneumatic connection via R or G thread</li> <li>• Double or single scale</li> <li>• Display units bar, in Hg, psi</li> </ul>	<ul style="list-style-type: none"> <li>• For high-pressure applications</li> <li>• Display units bar, psi, MPa</li> </ul>
<b>online:</b> →	<a href="#">dpa</a>	<a href="#">vam</a>	<a href="#">pagl</a>

## Customised components – for your specific requirements

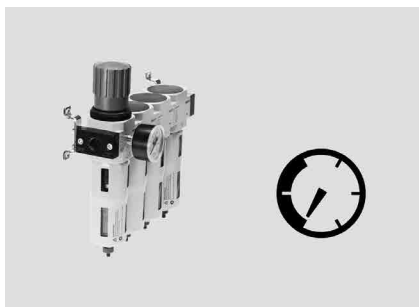

### Components for compressed air preparation with customised designs

Can't find the compressed air preparation components you need in our catalogue? We can offer you customised components that are tailored to your specific requirements – from minor product modifications to complete new product developments. Common product modifications:

- Modified pressure range
- Rotary knob: in a special colour, with protection against rotation
- Fitting: integrated throttling port, special thread
- Tubing with special printing
- Pressure gauge with red/green range

Many additional variants are possible. Ask your Festo sales engineer, who will be happy to help.



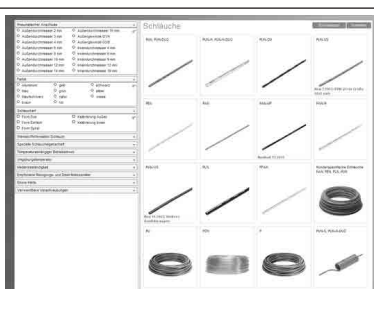
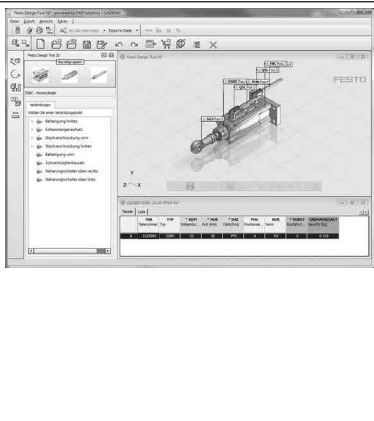

Further information on customised components can be found on your local website

→ [www.festo.com](http://www.festo.com)





Software tool

<p><b>Product Finder for tubing</b></p>		<p>Simply enter parameters such as working pressure, chemicals and required resistance to cleaning agents and have the program calculate the right tubing for your application.</p> <p>This tool can be found</p> <ul style="list-style-type: none"> <li>• either in the electronic catalogue by clicking on the blue button “Product finder”</li> <li>• or on the DVD under Engineering Tools.</li> </ul>
<p><b>Festo Design Tool 3D FDT 3D</b></p>		<p>The Festo Design Tool 3D is a 3D product configurator for generating specific CAD product combinations from Festo. The configurator makes your search for the right accessory easier, more reliable and faster.</p> <p>You can then order the module that has been created with a single order item – either completely pre-assembled or as individual parts in a single box. As a result, your bill of materials is considerably shortened and downstream processes such as product ordering, order picking and assembly are significantly simplified.</p> <p>All ordering options are available in the following countries: AT, BE, CH, CZ, DE, DK, ES, FI, FR, GB, HU, IE, IT, NL, NO, PL, RU, SE, SI, SK.</p> <p>This tool can be found</p> <ul style="list-style-type: none"> <li>• either via the address: <a href="http://www.festo.com/FDT-3D">www.festo.com/FDT-3D</a> in the above listed countries,</li> <li>• or on the CD “FDT 3D” (part no. 135595 for the above listed countries)</li> <li>• or on the DVD.</li> </ul>



O. D. tubing

	 <b>Plastic tubing PUN, PUN-DUO</b>	 <b>Plastic tubing PUN-H, PUN-H-DUO</b>	 <b>Plastic tubing PUN-CM</b>	 <b>Plastic tubing PUN-V0</b>
<b>Outside diameter</b>	3 ... 16 mm	2 ... 16 mm	4 ... 12 mm	4 ... 16 mm
<b>Inside diameter</b>	2 ... 11 mm	1.2 ... 11 mm	2.5 ... 8 mm	2 ... 11.8 mm
<b>Temperature-dependent operating pressure</b>	-0.95 ... 30 bar	-0.95 ... 10 bar	-0.95 ... 10 bar	-0.95 ... 30 bar
<b>Ambient temperature</b>	-35 ... 60 °C	-35 ... 60 °C	-35 ... 60 °C	-35 ... 60 °C
<b>New</b>		• Transparent versions		
<b>Quick ordering of selected basic designs</b>	★	★		
<b>Description</b>	<ul style="list-style-type: none"> <li>• Polyurethane</li> <li>• High resistance to stress cracks</li> <li>• Suitable for energy chains</li> <li>• Also available as DUO plastic tubing</li> <li>• Operating media: compressed air, vacuum</li> </ul>	<ul style="list-style-type: none"> <li>• Polyurethane</li> <li>• High resistance to microbes and hydrolysis</li> <li>• See supplementary information on food-safe materials at <a href="http://www.festo.com/sp">www.festo.com/sp</a> &gt; Certificates</li> <li>• Suitable for energy chains</li> <li>• Also available as DUO plastic tubing</li> <li>• Operating media: compressed air, vacuum, water</li> </ul>	<ul style="list-style-type: none"> <li>• Polyurethane</li> <li>• Plastic tubing, antistatic, electrically conductive</li> <li>• Suitable for energy chains</li> <li>• Operating media: compressed air, vacuum</li> </ul>	<ul style="list-style-type: none"> <li>• Polyurethane</li> <li>• Flame retardant to UL 94 V0 ... V2</li> <li>• For use in the immediate vicinity of welding applications</li> <li>• High resistance to microbes and hydrolysis</li> <li>• Suitable for energy chains</li> <li>• Operating medium: compressed air, vacuum, water</li> </ul>
<b>online:</b> →	<a href="#">pun</a>	<a href="#">pun-h</a>	<a href="#">pun-cm</a>	<a href="#">pun-v0</a>

## O. D. tubing

	 Plastic tubing PEN	 Plastic tubing PAN	 Plastic tubing PAN-MF	 Heavy-duty tubing PAN-R
<b>Outside diameter</b>	4 ... 16 mm	4 ... 16 mm	4 ... 16 mm	4 ... 28 mm
<b>Inside diameter</b>	2.7 ... 10.8 mm	2.5 ... 12 mm	2.5 ... 12 mm	2.5 ... 23 mm
<b>Temperature-dependent operating pressure</b>	-0.95 ... 10 bar	-0.95 ... 35 bar	-0.95 ... 31 bar	-0.95 ... 35 bar
<b>Ambient temperature</b>	-30 ... 60 °C	-60 ... 100 °C	-60 ... 100 °C	-30 ... 80 °C
<b>Description</b>	<ul style="list-style-type: none"> <li>• Polyethylene</li> <li>• High resistance to chemicals and very high resistance to hydrolysis</li> <li>• Resistant to most cleaning agents and lubricants</li> <li>• Suitable for energy chains</li> <li>• Operating media: compressed air, vacuum, water</li> </ul>	<ul style="list-style-type: none"> <li>• Polyamide</li> <li>• High thermal and mechanical load capacities</li> <li>• High resistance to microbes</li> <li>• Operating media: compressed air, vacuum</li> </ul>	<ul style="list-style-type: none"> <li>• Polyamide</li> <li>• High thermal and mechanical load capacities</li> <li>• Meets the requirements to DIN 73378 "Polyamide tubing for use in motor vehicles"</li> <li>• Operating media compressed air, mineral oil</li> </ul>	<ul style="list-style-type: none"> <li>• Polyamide</li> <li>• For applications with a high pressure range</li> <li>• High resistance to microbes</li> <li>• Operating medium: compressed air, vacuum</li> </ul>
<b>online: →</b>	<a href="#">pen</a>	<a href="#">pan</a>	<a href="#">pan</a>	<a href="#">pan-r</a>

## O. D. tubing



	 Plastic tubing PAN-V0	 Plastic tubing PLN	 Plastic tubing PFAN
<b>Outside diameter</b>	6 ... 14 mm	4 ... 16 mm	4 ... 12 mm
<b>Inside diameter</b>	2.5 ... 9 mm	2.9 ... 12 mm	2.9 ... 8.4 mm
<b>Temperature-dependent operating pressure</b>	-0.95 ... 12 bar	-0.95 ... 14 bar	-0.95 ... 16 bar
<b>Ambient temperature</b>	-30 ... 90 °C	-30 ... 80 °C	-20 ... 150 °C
<b>Description</b>	<ul style="list-style-type: none"> <li>• PVC, polyamide</li> <li>• Flame retardant to UL 94 V0</li> <li>• High resistance to microbes and UV radiation</li> <li>• Double-sheath tubing</li> <li>• Suitable for energy chains</li> <li>• Operating media: compressed air, vacuum, water, mineral oil</li> </ul>	<ul style="list-style-type: none"> <li>• Polyethylene</li> <li>• High resistance to chemicals, microbes and hydrolysis</li> <li>• See supplementary information on food-safe materials at <a href="http://www.festo.com/sp">www.festo.com/sp</a> &gt; Certificates</li> <li>• Resistant to most cleaning agents and lubricants</li> <li>• Operating media: compressed air, vacuum, water</li> </ul>	<ul style="list-style-type: none"> <li>• Perfluoroalkoxy alkane</li> <li>• Pneumatic tubing with resistance to high temperatures and chemicals</li> <li>• See supplementary information on food-safe materials at <a href="http://www.festo.com/sp">www.festo.com/sp</a> &gt; Certificates</li> <li>• High resistance to chemicals, microbes, UV radiation, hydrolysis and stress cracks</li> <li>• Operating medium: compressed air, vacuum, water</li> </ul>
<b>online: →</b>	<a href="#">pan-v0</a>	<a href="#">pln</a>	<a href="#">pfan</a>







I. D. tubing

	
	<b>Plastic tubing PU</b>
<b>Outside diameter</b>	11.6 ... 18 mm
<b>Inside diameter</b>	9 ... 13.1 mm
<b>Temperature-dependent operating pressure</b>	-0.95 ... 10 bar
<b>Ambient temperature</b>	-35 ... 60 °C
<b>Description</b>	<ul style="list-style-type: none"> <li>• Polyurethane with reinforcing fabric</li> <li>• High resistance to abrasion and kinks</li> <li>• Operating media: compressed air, vacuum (PU-13)</li> </ul>
<b>online: →</b>	<a href="#">pu</a>



Spiral tubing

			
	<b>Spiral plastic tubing PUN-S, PUN-S-DUO</b>	<b>Spiral plastic tubing PUN-SG</b>	<b>Spiral plastic tubing PPS</b>
<b>Outside diameter</b>	4 ... 12 mm	9.5 ... 11.7 mm	6.3 ... 7.8 mm
<b>Inside diameter</b>	2.6 ... 8 mm	6.4 ... 7.9 mm	4.7 ... 6.2 mm
<b>Working length</b>	0.5 ... 6 m	2.4 ... 6 m	7.5 ... 15 m
<b>Temperature-dependent operating pressure</b>	-0.95 ... 10 bar	-0.95 ... 15 bar	-0.95 ... 21.2 bar
<b>Ambient temperature</b>	-35 ... 60 °C	-40 ... 60 °C	-30 ... 80 °C
<b>Description</b>	<ul style="list-style-type: none"> <li>• Polyurethane</li> <li>• Also available as DUO plastic tubing</li> <li>• Operating media: compressed air, vacuum</li> </ul>	<ul style="list-style-type: none"> <li>• Polyurethane, nickel-plated brass, polyacetal</li> <li>• Pre-assembled with captive rotatable fittings</li> <li>• High resistance to microbes and hydrolysis</li> <li>• Operating media: compressed air, vacuum</li> </ul>	<ul style="list-style-type: none"> <li>• Polyamide, brass, galvanised steel</li> <li>• Pre-assembled with 2 rotatable connectors and captive sealing rings OL</li> <li>• Highly resistant to microbes</li> <li>• Operating medium: compressed air, vacuum, water</li> </ul>
<b>online: →</b>	<a href="#">spiral</a>	<a href="#">spiral</a>	<a href="#">pps</a>

## Push-in fittings

	 <b>Push-in fittings NPQH</b>	 <b>Push-in fittings/connectors, metal, standard NPQM</b>	 <b>Push-in fittings/connectors, resistant to media NPQP</b>	 <b>Cartridges QSP10, QSPK, QSPKG, QSPLK, QSPLKG, QSPLLK, QSPLKKG</b>
<b>Pneumatic connection 1</b>	Male thread G1/2, G1/4, G1/8, G3/8, M5, M7, female thread G1/4, G1/8, push-in sleeve QS-10, QS-12, QS-14, QS-4, QS-6, QS-8, for tubing O. D. 10 mm, 12 mm, 14 mm, 4 mm, 6 mm, 8 mm	Push-in sleeve QS-10, QS-12, QS-14, QS-4, QS-6, QS-8, for tubing O. D. 10 mm, 12 mm, 14 mm, 4 mm, 6 mm, 8 mm, G1/2, G1/4, G1/8, G3/8, M5, M7	Push-in sleeve QS-10, QS-12, QS-4, QS-6, QS-8, for tubing O. D. 10 mm, 12 mm, 4 mm, 6 mm, 8 mm, R1/2, R1/4, R1/8, R3/8	Cartridge 10 mm, 14 mm, 18 mm, 20 mm
<b>Pneumatic connection 2</b>	Push-in sleeve QS-10, QS-12, QS-14, QS-4, QS-6, QS-8, for tubing O. D. 10 mm, 12 mm, 14 mm, 4 mm, 6 mm, 8 mm	For tubing O. D. 10 mm, 12 mm, 14 mm, 3 mm, 4 mm, 6 mm, 8 mm	For tubing O. D. 10 mm, 12 mm, 4 mm, 6 mm, 8 mm	For tubing O. D. 10 mm, 12 mm, 3 mm, 4 mm, 6 mm, 8 mm
<b>Temperature-dependent operating pressure</b>			-0.95 ... 10 bar	
<b>Operating pressure</b>	-0.95 ... 20 bar	-0.95 ... 16 bar		-0.95 ... 10 bar
<b>Ambient temperature</b>	0 ... 150 °C	-20 ... 70 °C	-20 ... 60 °C	-10 ... 60 °C
<b>Description</b>	<ul style="list-style-type: none"> <li>• Solid-metal brass, chemically nickel-plated</li> <li>• High corrosion and chemical resistance</li> <li>• Highly resistant to temperatures and pressure</li> <li>• See supplementary information on food-safe materials at <a href="http://www.festo.com/sp">www.festo.com/sp</a> &gt; Certificates</li> <li>• Operating media compressed air, vacuum, water</li> </ul>	<ul style="list-style-type: none"> <li>• Solid-metal brass, nickel-plated</li> <li>• Attractively priced metal push-in fitting</li> <li>• Sturdy</li> <li>• Operating media: compressed air, vacuum, water</li> </ul>	<ul style="list-style-type: none"> <li>• Polypropylene</li> <li>• Low-cost alternative to stainless steel: resistant to most cleaning agents in combination with tubing PLN</li> <li>• For use with extreme media influences</li> <li>• See supplementary information on food-safe materials at <a href="http://www.festo.com/sp">www.festo.com/sp</a> &gt; Certificates</li> <li>• Operating media compressed air, vacuum</li> </ul>	<ul style="list-style-type: none"> <li>• Cartridge fittings</li> <li>• Straight or angled design</li> <li>• PBT and nickel-plated brass</li> <li>• Operating medium: compressed air, vacuum</li> </ul>
<b>online:</b> →	<a href="#">npqh</a>	<a href="#">npqm</a>	<a href="#">npqp</a>	<a href="#">qsp</a>

Push-in fittings

			
	<b>Push-in fittings, mini series</b> QSM, QSMC, QSMF, QSMP, QSMS, QSML, QSMLL, QSMLV, QSMLLV, QSMT, QSMTL, QSMX, QSMY	<b>Push-in fittings, standard</b> QS, QSF, QSS, QSSF, QSC, QSH, QSL, QSL, QSLF, QSLV, QST, QSTF, QSTL, QSW, QSX, QSY, QSYL, QSYLV, QSYTF	<b>Push-in fittings, stainless steel</b> CRQS, CRQSL, CRQSS, CRQST, CRQSY
<b>Pneumatic connection 1</b>	Male thread G1/8, M3, M5, M6, M6x0.75, M7, M8x0.75, R1/8, female thread M3, M5, push-in sleeve QS-2, QS-3, QS-4, QS-6, for tubing O. D. 2 mm, 3 mm, 4 mm, 6 mm	Male thread G1/2, G1/4, G1/8, G3/4, G3/8, M5, R1/2, R1/4, R1/8, R3/8, female thread G1/2, G1/4, G1/8, G3/8, push-in sleeve QS-10, QS-12, QS-16, QS-4, QS-6, QS-8, for tubing O. D. 10 mm, 12 mm, 16 mm, 4 mm, 6 mm, 8 mm	Male thread M5, R1/2, R1/4, R1/8, R3/8, for tubing O. D. 10 mm, 12 mm, 16 mm, 4 mm, 6 mm, 8 mm
<b>Pneumatic connection 2</b>	For tubing O. D. 2 mm, 3 mm, 4 mm, 6 mm	Female thread G1/2, G1/4, G1/8, G3/8, push-in sleeve QS-10, QS-12, QS-16, QS-4, QS-6, QS-8, for tubing O. D. 10 mm, 12 mm, 16 mm, 22 mm, 4 mm, 6 mm, 8 mm	For tubing O. D. 10 mm, 12 mm, 16 mm, 4 mm, 6 mm, 8 mm
<b>Temperature-dependent operating pressure</b>	-0.95 ... 14 bar	-0.95 ... 14 bar	
<b>Operating pressure</b>	-0.95 ... 6 bar	-0.95 ... 14 bar	-0.95 ... 10 bar
<b>Ambient temperature</b>	-10 ... 80 °C	-20 ... 80 °C	-15 ... 120 °C
<b>Quick ordering of selected basic designs</b>	★	★	
<b>Description</b>	<ul style="list-style-type: none"> <li>• Mini series</li> <li>• Compact for maximum component density in confined spaces</li> <li>• PBT and nickel-plated brass</li> <li>• Operating media: compressed air, vacuum, (water)</li> </ul>	<ul style="list-style-type: none"> <li>• Standard series</li> <li>• Wide range of variants: large selection for maximum flexibility in standard applications</li> <li>• PBT and nickel-plated brass</li> <li>• Operating media: compressed air, vacuum, (water)</li> </ul>	<ul style="list-style-type: none"> <li>• Maximum corrosion resistance (corrosion resistance class 4 according to Festo standard 940 070) and chemical resistance</li> <li>• See supplementary information on food-safe materials at <a href="http://www.festo.com/sp">www.festo.com/sp</a> &gt; Certificates</li> <li>• Operating media: compressed air, vacuum, (water)</li> <li>• Stainless steel</li> </ul>
<b>online: →</b>	<a href="#">qsm</a>	<a href="#">qs</a>	<a href="#">crqs</a>

## Push-in fittings







**Push-in fittings, resistant to welding spatter**  
**QS-V0, QSL-V0, QST-V0**





**Self-sealing/rotary push-in fittings and connectors**  
**QSK, QSSK, QSKL, QSR, QSRL**

<b>Pneumatic connection 1</b>	For tubing O. D. 10, 12, 4, 6, 8, G1/2, G1/4, G1/8, G3/8, R1/2, R1/4, R1/8, R3/8	Male thread G1/2, G1/4, G1/8, G3/8, M5, R1/2, R1/4, R1/8, R3/8, for tubing O. D. 10 mm, 12 mm, 4 mm, 6 mm, 8 mm
<b>Pneumatic connection 2</b>	For tubing O. D. 10 mm, 12 mm, 4 mm, 6 mm, 8 mm	For tubing O. D. 10 mm, 12 mm, 4 mm, 6 mm, 8 mm
<b>Temperature-dependent operating pressure</b>		-0.95 ... 14 bar
<b>Operating pressure</b>	-0.95 ... 10 bar	-0.95 ... 6 bar
<b>Ambient temperature</b>	0 ... 60 °C	-10 ... 80 °C
<b>Description</b>	<ul style="list-style-type: none"> <li>• PBT, reinforced</li> <li>• Resistant to welding spatter</li> <li>• For use in all areas where there is a risk of fire</li> <li>• Reliable even for applications in close proximity to welding spatter</li> <li>• Operating medium: compressed air, vacuum, water</li> </ul>	<ul style="list-style-type: none"> <li>• Standard series</li> <li>• Self-sealing push-in fitting blocks the air flow after the tubing is disconnected</li> <li>• PBT and nickel-plated brass</li> <li>• Push-in fitting, rotatable with swivel connection, rotatable by 360° with max. 500 rpm</li> <li>• Operating medium: compressed air, vacuum</li> </ul>
<b>online: →</b>	<a href="#">qs-v0</a>	<a href="#">qsr</a>



Barbed fittings

	 <b>Quick connectors NPCK</b>	 <b>Barbed fittings CN, CRCN, FCN, L-PK, LCN, N, RTU, SCN, LCNH, T-PK, TCN, V-PK, Y-PK</b>	 <b>Barbed hose fittings C-P, N-P, N-MS, SK</b>	 <b>Quick connectors ACK, CK, QCK, SCK, CV-PK, GCK-KU, LCK, LCKN, TCK, KCK-KU, FCK-KU, MCK, LK, TK, VT</b>
<b>Nominal width</b>	2 ... 6.2 mm	1.3 ... 5.3 mm	4 ... 16.5 mm	2 ... 12 mm
<b>Pneumatic connection 1</b>	Male thread G1/4, G1/8, G3/8, M5	Male thread G1/4, G1/8, G3/8, M3, M5, for tubing O. D. 3 mm, 4 mm, 6 mm, 8 mm	Male thread G1, G1/2, G1/4, G1/8, G3/4, G3/8, female thread G1/2, G1/4, G1/8, G3/8, NPT1-11 1/2, NPT3/4-14	Male thread G1/2, G1/4, G1/8, G3/8, M5, R1/4, R1/8, R3/8, female thread G1/2, G1/4, G1/8, G3/8, M5, for barbed connector I. D. 3 mm, 4 mm, 6 mm, 9 mm with union nut
<b>Pneumatic connection 2</b>	For tubing O. D. 10 mm, 4 mm, 6 mm, 8 mm	For tubing O. D. 3 mm, 4 mm, 6 mm, 8 mm	For tubing O. D. 8 mm, for tubing I. D. 19 mm, 13 mm, 9 mm	For tubing O. D. 4 mm, 6 mm, 8 mm, for tubing I. D. 13 mm, 9 mm, for barbed fitting I. D. 13 mm, 3 mm, 4 mm, 6 mm, 9 mm with union nut
<b>Operating pressure</b>	-0.95 ... 12 bar	-0.95 ... 10 bar	-0.95 ... 16 bar	0 ... 16 bar
<b>Ambient temperature</b>	-20 ... 120 °C	0 ... 60 °C		-10 ... 60 °C
<b>Description</b>	<ul style="list-style-type: none"> <li>• Stainless steel design</li> <li>• See supplementary information on food-safe materials at <a href="http://www.festo.com/sp">www.festo.com/sp</a> &gt; Certificates</li> <li>• Fulfils all Clean Design requirements</li> <li>• Straight shape</li> <li>• Operating media: compressed air, vacuum, water</li> </ul>	<ul style="list-style-type: none"> <li>• Straight shape, T-shape, L-shape, Y-shape</li> <li>• Operating media: compressed air, vacuum</li> <li>• Brass, POM, aluminium or stainless steel</li> </ul>	<ul style="list-style-type: none"> <li>• Barbed hose fitting with or without sealing ring</li> <li>• Tubing clip to DIN 3017</li> <li>• Operating media: compressed air, vacuum</li> <li>• Brass or aluminium, steel</li> </ul>	<ul style="list-style-type: none"> <li>• Bulkhead quick connector</li> <li>• Sealing cap for plastic tube fittings and barbed connectors</li> <li>• Multiple distributor</li> <li>• Union nut for CK tube fitting</li> <li>• Operating media: compressed air, vacuum, (water)</li> <li>• Aluminium, steel, POM or zinc</li> </ul>
<b>online:</b> →	<a href="#">npck</a>	<a href="#">n_070302</a>	<a href="#">n_cnp</a>	<a href="#">ck</a>

## Threaded fittings

	 <b>Threaded fittings NPFC</b>	 <b>Adapters NPFV</b>	 <b>Reducers, sleeves, double nipples D, E, ESK, FR, G, LJK, NPFA, QM, QMR, QSP10, SCM, TJK</b>
<b>Pneumatic connection 1</b>	G1, G1/2, G1/4, G1/8, G3/4, G3/8, M5, M7, R1, R1/2, R1/4, R1/8, R3/4, R3/8	G1/4	G1, G1/2, G1/4, G1/8, G3/4, G3/8, M3, M5, M7, R1/2, R1/4, R1/8, R3/8
<b>Pneumatic connection 2</b>	G1, G1/2, G1/4, G1/8, G3/4, G3/8, M5, R1, R1/2, R1/4, R1/8, R3/4, R3/8	G1/4, NPT1/4-18	G1, G1/2, G1/4, G1/8, G3/4, G3/8, M3, M5, M7, R1/2, R1/4, R1/8, R3/8
<b>Operating pressure</b>	-0.95 ... 50 bar	2 ... 8 bar	0.9 ... 8 bar
<b>Operating pressure for entire temperature range</b>			
<b>Ambient temperature</b>	-20 ... 150 °C		
<b>Nominal width</b>		6 mm	2.6 ... 10.7 mm
<b>Description</b>	<ul style="list-style-type: none"> <li>Nickel-plated brass</li> <li>Sleeve</li> <li>Reducing sleeve</li> <li>Extension</li> <li>Double nipple</li> <li>Reducing nipple</li> <li>L-, T-, Y- or X-fitting</li> <li>Operating media: compressed air, vacuum</li> </ul>	<ul style="list-style-type: none"> <li>Aluminium</li> <li>Adapter with filter</li> <li>From G1/4 to NPT1/4 or G1/4</li> <li>Operating media: compressed air, vacuum</li> </ul>	<ul style="list-style-type: none"> <li>Brass or aluminium</li> <li>Reducing nipple</li> <li>Reducing sleeve</li> <li>Double nipple</li> <li>Distributor block</li> <li>Female bulkhead fitting</li> <li>Sleeve</li> <li>Operating medium: compressed air, vacuum</li> </ul>
<b>online: →</b>	<a href="#">npfc</a>	<a href="#">npfv</a>	<a href="#">esk</a>



## Threaded fittings

	 <b>Ring pieces, hollow bolts LK, TK, VT</b>	 <b>Blanking plugs B</b>
<b>Pneumatic connection 1</b>	Male thread G1/4, G1/8, G3/8, M5	
<b>Pneumatic connection 2</b>	For barbed connector I. D. 3 mm with union nut, 4 mm, 6 mm with union nut	
<b>Operating pressure</b>		
<b>Operating pressure for entire temperature range</b>	0 ... 10 bar	
<b>Ambient temperature</b>		
<b>Nominal width</b>		
<b>Quick ordering of selected basic designs</b>		★
<b>Description</b>	<ul style="list-style-type: none"> <li>Multiple distributor consisting of hollow bolt VT and ring piece LK or TK</li> <li>With two to six outlets and one common air feed</li> <li>Operating media: compressed air, vacuum</li> <li>Galvanised steel</li> </ul>	<ul style="list-style-type: none"> <li>Aluminium, stainless steel</li> <li>With sealing ring</li> </ul>
<b>online: →</b>	<a href="#">lk</a>	<a href="#">b-1</a>

Click fitting

	 <p><b>Click fittings</b> <b>NPKA</b></p>
<b>Pneumatic connection 1</b>	Male thread G1/8
<b>Pneumatic connection 2</b>	For tubing O. D. 6 mm
<b>Temperature-dependent operating pressure</b>	-0.95 ... 10 bar
<b>Nominal width</b>	4 mm
<b>Ambient temperature</b>	-10 ... 60 °C
<b>Description</b>	<ul style="list-style-type: none"> <li>• POM, polyamide 66</li> <li>• Quick and simple tube installation using one hand</li> <li>• Completely plastic</li> <li>• Suitable for use in cleaning-intensive areas.</li> <li>• See supplementary information on food-safe materials at <a href="http://www.festo.com/sp">www.festo.com/sp</a> &gt; Certificates</li> <li>• Operating media compressed air, vacuum, water</li> </ul>
<b>online: →</b>	<a href="#">npka</a>



Piping

	 <p><b>Plastic pipes</b> <b>PQ-PA</b></p>	 <p><b>Piping</b> <b>PQ-AL</b></p>	 <p><b>Plastic-coated metal tubes</b> <b>PM</b></p>
<b>Outside diameter</b>	12 ... 28 mm	12 ... 28 mm	6 ... 8 mm
<b>Information on materials: tubing</b>	PA	Wrought aluminium alloy	Wrought aluminium alloy, PE
<b>Temperature-dependent operating pressure</b>	-0.95 ... 15 bar	-0.95 ... 15 bar	-0.95 ... 30 bar
<b>Ambient temperature</b>	-25 ... 75 °C	-30 ... 75 °C	-29 ... 65 °C
<b>Description</b>	<ul style="list-style-type: none"> <li>• Rigid pipe made from high-quality polyamide</li> <li>• Smooth inside wall ensures optimum flow conditions</li> <li>• Operating media: compressed air, vacuum, liquid media</li> </ul>	<ul style="list-style-type: none"> <li>• Rigid aluminium pipe</li> <li>• Smooth inside wall ensures optimum flow conditions</li> <li>• Operating media: compressed air, vacuum, liquid media</li> </ul>	<ul style="list-style-type: none"> <li>• Polyethylene, aluminium</li> <li>• Can be bent straight and reshaped several times without a pipe-bending device and without being damaged</li> <li>• Resistant to deformation</li> <li>• Operating medium: compressed air, vacuum</li> </ul>
<b>online: →</b>	<a href="#">pq-pa</a>	<a href="#">pq-al</a>	<a href="#">pm</a>

## Push-in fittings for piping PQ





	 <p><b>Push-in fittings</b> CQ, CQA, CQC, CQD, CQH, CQL, CQO, CQSR, CQT</p>
<b>Pneumatic connection 1</b>	Male thread G1, G1/2, G3/4, G3/8, female thread G1/2, push-in sleeve CQ-12, CQ-15, CQ-18, CQ-22, CQ-28, QS-16, for pipe/tubing O. D. 12 mm, 15 mm, 18 mm, 22 mm, 28 mm
<b>Pneumatic connection 2</b>	Female thread G1/2, push-in sleeve CQ-12, CQ-15, CQ-18, CQ-22, CQ-28, QS-12, QS-16, for pipe/tubing O. D. 12 mm, 15 mm, 18 mm, 22 mm, 28 mm
<b>Nominal width</b>	8 ... 24.9 mm
<b>Temperature-dependent operating pressure</b>	-0.95 ... 15 bar
<b>Ambient temperature</b>	-25 ... 70 °C
<b>Description</b>	<ul style="list-style-type: none"> <li>• For pipes PQ-PA, PQ-AL and tubing PAN and PUN</li> <li>• Operating media: compressed air, vacuum, liquid media</li> <li>• POM</li> </ul>
<b>online: →</b>	<a href="#">cq</a>

## Couplings



	 <p><b>Quick coupling sockets, quick coupling plugs</b> KD1, KD2, KD3, KD4, KD5, KS1, KS2, KS3, KS4, KS5</p>	 <p><b>Multiple connectors</b> KSV, KDV, KDVF</p>	 <p><b>Multi-tube connectors</b> KM</p>
<b>Pneumatic port</b>		For tubing O. D. 3, 4, 6, 8, PK-2, PK-3, PK-4, PK-6	PK-2, PK-3, PK-4
<b>Pneumatic connection 1</b>	Male thread G1/2, G1/4, G1/8, G3/8, M3, M5, female thread G1/2, G1/4, G1/8, G3/8, M5, CK-13, CK-3, CK-4, CK-6, CK-9, CN-2, CN-4, CN-6, N-6, N-9, N-13		
<b>Standard nominal flow rate</b>	44 ... 2043 l/min		
<b>Operating pressure</b>		-0.95 ... 16 bar	-0.95 ... 8 bar
<b>Ambient temperature</b>	-10 ... 80 °C	-10 ... 60 °C	-10 ... 60 °C
<b>Description</b>	<ul style="list-style-type: none"> <li>• Quick connection coupling for standard applications without safety function</li> <li>• Shut off at one or both ends</li> <li>• With male or female thread or with barbed fitting or quick connector</li> <li>• Nickel-plated brass</li> <li>• Operating media: compressed air, vacuum</li> </ul>	<ul style="list-style-type: none"> <li>• POM, aluminium, brass</li> <li>• Multi-plug, multi-socket</li> <li>• Terminal plug and terminal socket</li> <li>• Operating media: compressed air, vacuum</li> </ul>	<ul style="list-style-type: none"> <li>• Polymer, brass</li> <li>• For max. 22 lines</li> <li>• Used as control cabinet outlet</li> <li>• Operating medium: compressed air, vacuum</li> </ul>
<b>online: →</b>	<a href="#">kd1</a>	<a href="#">ksv</a>	<a href="#">km</a>



Distributors

	 <b>Multiple distributors QSLV, QSQ, QST3</b>	 <b>Multiple distributors QSYTF</b>	 <b>Distributors FR</b>	 <b>Rotary distributors GF</b>
<b>Pneumatic connection 1</b>	Male thread G1/2, G1/4, G1/8, G3/8, R1/2, R1/4, R1/8, R3/8, for tubing O. D. 10 mm, 6 mm, 8 mm	Male thread G1/2, G1/4, G1/8, G3/8, R1/2, R1/4, R1/8, R3/8	Female thread G1/2, G1/4, G1/8, G3/8, G3/4	Male thread G1/4, G3/8, G1/2, G1/8
<b>Pneumatic connection 2</b>	For tubing O. D. 10 mm, 12 mm, 4 mm, 6 mm, 8 mm	Female thread G1/2, G1/4, G1/8, G3/8, for tubing O. D. 10 mm, 12 mm, 6 mm, 8 mm	Female thread G1/2, G1/4, G1/8, G3/8, M3, M5, for tubing O. D. 4 mm, 6 mm	Female thread G1/4, G3/8, G1/2, G1/8, M5
<b>No. of supply lines</b>	1	1	1	
<b>No. of outlets</b>	2, 3, 4, 6	3	3, 8, 9, 12	
<b>Maximum speed</b>				300 ... 3000 1/min
<b>Description</b>	<ul style="list-style-type: none"> <li>• PBT and nickel-plated brass</li> <li>• L-shape, T-shape</li> <li>• Rotatable 360°</li> <li>• Reducing design</li> <li>• Operating media: compressed air, vacuum, (water)</li> </ul>	<ul style="list-style-type: none"> <li>• PBT and nickel-plated brass</li> <li>• Y-shape</li> <li>• Rotatable 360°</li> <li>• Operating media: compressed air, vacuum, (water)</li> </ul>	<ul style="list-style-type: none"> <li>• Aluminium</li> <li>• 4, 8, 9 or 12 connections</li> <li>• Operating medium: compressed air, vacuum</li> </ul>	<ul style="list-style-type: none"> <li>• 2 or 4 axial and radial outlets</li> <li>• Single or multiple rotary distributor</li> <li>• Operating media: compressed air, vacuum</li> <li>• Brass, hardened steel</li> </ul>
<b>online: →</b>	<a href="#">qslv</a>	<a href="#">qsytf</a>	<a href="#">fr</a>	<a href="#">gf</a>

Protective conduit systems



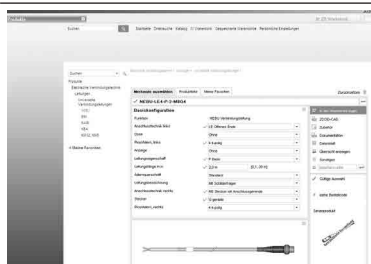

	 <b>Protective conduits MK, MKG, MKR, MKV</b>	 <b>Fittings HMZAS, HMZV, MKA, MKGV, MKM, MKRL, MKRS, MKRT, MKRV, MKVM, MKVV, MKY</b>
<b>Inside diameter</b>	7.5 ... 48 mm	
<b>Outside diameter</b>	10 ... 52 mm	
<b>Design</b>	Strip-wound metal conduit, internally and externally corrugated all-plastic conduit, separable	
<b>Ambient temperature</b>	-20 ... 100 °C	-40 ... 200 °C
<b>Description</b>	<ul style="list-style-type: none"> <li>• For protecting pneumatic tubing and electrical cables</li> <li>• Galvanised steel, PA, PP, PVC spring steel</li> <li>• Metal or plastic design</li> <li>• High alternate bending strength</li> </ul>	<ul style="list-style-type: none"> <li>• Installation kit</li> <li>• Junction box</li> <li>• Adapter connector</li> <li>• Protective conduit fitting</li> <li>• Lock nut</li> <li>• Protective conduit connector</li> <li>• Y-distributor</li> <li>• Polymer, polyamide, nickel-plated brass</li> </ul>
<b>online: →</b>	<a href="#">mkg</a>	<a href="#">mka</a>

### Configurator







Design a product with numerous features reliably and quickly with the help of the configurator. Select all the required product features step-by-step. The use of logic checks ensures that only correct configurations are available for selection. The configurator is part of the electronic catalogue and is not available as a separate software program.

## Universal connecting cables





	 <b>Connecting cables NEBU</b>	 <b>Connecting cables/plug sockets with cable SIM</b>	 <b>Connecting cables KM12</b>
<b>Electrical connection</b>	M8x1, M12x1, straight plug, angled plug, straight socket, angled socket, rotatable socket, 7/8" round plug connector, open end, 2-pin, 3-pin, 4-pin, 5-pin, 2-wire, 3-wire, 4-wire, 5-wire, rotatable thread, straight plug / open end, angled socket / angled plug, angled socket / open end, straight socket / straight plug, straight socket / angled socket, straight socket / open end, M8x1 / -, M8x1 / M8x1, M8x1 / M12x1, M12x1 / -, M12x1 / M12x1, M12x1 / M8x1, 3-pin / 3-pin, 3-pin / 4-pin, 4-pin / 4-pin, 5-pin / 4-pin, 5-pin / 5-pin, 3-pin / 3-wire, 4-pin / 4-wire, 5-pin / 3-wire, 5-pin / 4-wire, 5-pin / 5-wire, - / rotatable thread	Straight socket, angled socket, 3-pin, 4-pin, clip-on, angled socket / open end, straight socket / open end, M8x1 / -, M12x1 / -, 3-pin / 3-wire, 4-pin / 4-wire, 5-pin / 3-wire, 5-pin / 4-wire, 5-pin / 5-wire	
<b>Electrical connection 1 and 2, function</b>	Field device side, controller side	Field device side, controller side	Field device side, controller side
<b>Electrical connection 1 and 2, connection type</b>	Socket, cable	Socket, cable	Socket, plug
<b>Electrical connection 1 and 2, cable outlet</b>	angled	Straight, angled	Straight
<b>Electrical connection 1 and 2, design</b>	Round	Round	Round
<b>Electrical connection 1 and 2, connection technology</b>	M12x1, A-coded to EN 61076-2-101, open end	M12x1, A-coded to EN 61076-2-101, open end	M12x1, A-coded to EN 61076-2-101 open end
<b>Electrical connection 1 and 2, number of pins/wires</b>	8	3, 4, 8	8
<b>Cable length</b>	0.1 ... 30 m	2 ... 10 m	2 m
<b>Quick ordering of selected basic designs</b>			
<b>Description</b>	<ul style="list-style-type: none"> <li>• Designs for static, standard, energy chain and robot applications</li> <li>• Versions with switching status display</li> <li>• Designs for connecting sensors and actuators</li> </ul>	<ul style="list-style-type: none"> <li>• Pre-assembled, pre-assembled at both ends</li> </ul>	<ul style="list-style-type: none"> <li>• For connecting inputs and outputs</li> <li>• Type of mounting: union nut, threaded connector</li> </ul>
<b>online: →</b>	<a href="#">nebu</a>	<a href="#">sim</a>	<a href="#">km12</a>

14

Connecting cables for control systems

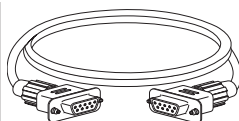

	 <p><b>Connecting cables NEBC</b></p>	 <p><b>Connecting cables, diagnostic cables SBOA</b></p>	 <p><b>Cables FEC-KBG</b></p>	 <p><b>Connecting cables NEBP</b></p>
<b>Electrical connection</b>	M12x1, straight plug, socket, straight plug, USB 2.0 type B, 4-pin, straight plug, M12x1, 4-pin, D-coded, straight plug, RJ45, 4-pin, straight plug, M12x1, 4-pin, D-coded, screenable, angled plug, M9, 5-pin, straight plug, USB 2.0 type A, 4-pin, straight plug M12x1, 4-pin, D, open end, 26-wire, straight plug, Sub-D, 25-pin, open end, 4-wire, open end, 5-wire, Sub-D, 5-pin, 9-pin, 15-pin, 25-pin, straight plug / open end, straight socket / straight socket, square design angled Sub-D/Sub-D, Sub-D/-, 15-pin/9-pin	Straight plug connector/ straight socket/straight socket	RJ11 plug / Sub-D, socket, 15-pin, RJ12 plug / Sub-D, socket, 15-pin	Angled socket, M16x0.75, 6-pin Angled plug connector, M9x0.5, 5-pin
<b>Electrical connection 1 and 2, function</b>	Field device side, controller side			
<b>Electrical connection 1 and 2, connection type</b>	Plug, cable			
<b>Electrical connection 1 and 2, cable outlet</b>	Straight			
<b>Electrical connection 1 and 2, design</b>	Square			
<b>Electrical connection 1 and 2, connection technology</b>	Sub-D, open end			
<b>Electrical connection 1 and 2, number of pins/wires</b>	15			
<b>Cable length</b>	0.25 ... 20 m	2 m	2.5 ... 5 m	2 m
<b>New</b>	<ul style="list-style-type: none"> <li>Additional versions</li> </ul>			
<b>Description</b>	<ul style="list-style-type: none"> <li>For I/O interface</li> <li>For connecting motor controller CMMS-ST to any control system</li> </ul>	<ul style="list-style-type: none"> <li>Used as Ethernet diagnostic cable, for integration in a CPI system, for I/O extension, for compact vision system type SBOC-Q, SBOI-Q</li> </ul>	<ul style="list-style-type: none"> <li>For connecting electrical terminal CPX to operator unit FED</li> </ul>	<ul style="list-style-type: none"> <li>Connection between linear drive DGPI, DGPIL or displacement encoder MME and measuring module CPX-CMIX</li> </ul>
<b>online: →</b>	<a href="#">nebc</a>	<a href="#">sboa</a>	<a href="#">fec-kbg</a>	<a href="#">575898</a>

## Connecting cables for control systems



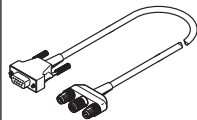

	 <b>Pilot cables KES</b>	 <b>Programming cables KDI</b>	 <b>Programming cables PS1</b>	 <b>Connecting cables KV-M12</b>
<b>Electrical connection</b>		Straight plugs / straight sockets, straight socket / straight plug, M8x1 / Sub-D, Sub-D / Sub-D, 4-pin / 9-pin, 9-pin / 9-pin	Sub-D, 9-pin	Straight socket, M12, 5-pin, A-coded, straight plug, M12x1, 5-pin, A-coded
<b>Electrical connection 1 and 2, function</b>	Field device side, controller side			
<b>Electrical connection 1 and 2, connection type</b>	Socket, cable			
<b>Electrical connection 1 and 2, cable outlet</b>	Straight			
<b>Electrical connection 1 and 2, design</b>	Square			
<b>Electrical connection 1 and 2, connection technology</b>	Sub-D, open end			
<b>Electrical connection 1 and 2, number of pins/wires</b>	9, 10, 15, 18			
<b>Cable length</b>	2.5 ... 10 m	2.5 ... 3 m	1.5 m	1.5 ... 3.5 m
<b>Description</b>	<ul style="list-style-type: none"> <li>For I/O interface for connecting motor controller SFC-DC to any controller</li> <li>For I/O interface for connecting motor unit MTR-DCI to any controller</li> </ul>	<ul style="list-style-type: none"> <li>Pre-assembled at both ends</li> <li>For diagnostic interface</li> <li>For servo motor MTR-DCI</li> </ul>	<ul style="list-style-type: none"> <li>Connecting cable for motor controller CMMS-ST</li> </ul>	<ul style="list-style-type: none"> <li>Plug socket with cable for diagnostic interface (to CPX terminal)</li> <li>Pre-assembled at both ends</li> <li>5-pin/4-wire</li> <li>Round plug</li> <li>Mounting via union nut M12</li> </ul>
<b>online: →</b>	<a href="#">kes</a>	<a href="#">kdi</a>	<a href="#">cmms-st</a>	<a href="#">kv-m12</a>

## Connecting cables for motors

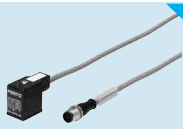

14

	 <b>Motor, encoder, resolver cables NEBM</b>	 <b>Motor cables KMTR</b>	 <b>Power supply cables KPWR</b>	 <b>Fieldbus adapters FBA</b>
<b>Cable length</b>	1 ... 25 m	2.5 ... 10 m	2.5 ... 10 m	0.1 ... 0.11 m
<b>Description</b>	<ul style="list-style-type: none"> <li>For servo motor EMMS-AS and stepper motor EMMS-ST</li> <li>Suitable for energy chains</li> </ul>	<ul style="list-style-type: none"> <li>For motor controllers SFC-DC</li> </ul>	<ul style="list-style-type: none"> <li>For motor units MTR-DCI</li> <li>For motor controllers SFC-DC for connecting load and logic supply</li> </ul>	<ul style="list-style-type: none"> <li>9-pin Sub-D plug to 5-pin round plug/M12 socket</li> </ul>
<b>online: →</b>	<a href="#">nebm</a>	<a href="#">kmtr</a>	<a href="#">kpwr</a>	<a href="#">fba</a>

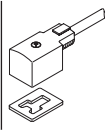
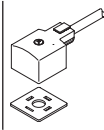

Connecting cables for valves

	 <p><b>Connecting cables/plug sockets with cable NEBV-H1, NEBV-M8</b></p>	 <p><b>Connecting cables NEDV</b></p>	 <p><b>Plug sockets with cable KMYZ-2, KMYZ-4</b></p>	 <p><b>Plug sockets with cable KMEB-1, KMEB-2, KMEB-3</b></p>
<b>Electrical connection</b>	M8x1, socket, 2-pin, angled socket / straight plug, angled socket / cable, M8x1 / M8x1, 4-pin / 3-pin, 4-pin / 2-wire	2x angled socket, M12, 3-pin, angled plug, M8, 4-pin	Cable, angled socket, square design MSZB, square design MSZC, angled socket / straight plug, angled socket / cable, square design / M8x1, square design / open end, 2-pin / 3-pin, 2-pin / 2-wire	Angled socket, to DIN EN 175301-803, type C, 2-pin, 3-pin, 4-pin, 5-pin
<b>Cable length</b>	0.2 ... 10 m	0.2 m	0.5 ... 10 m	0.5 ... 10 m
<b>New</b>	<ul style="list-style-type: none"> <li>Additional versions</li> </ul>			
<b>Quick ordering of selected basic designs</b>	★			★
<b>Description</b>	<ul style="list-style-type: none"> <li>Connecting cable for valves with ZC solenoid coils (CPE10, CPE14), for valves VUVG</li> <li>Pre-assembled</li> </ul>	<ul style="list-style-type: none"> <li>For proportional valves VPWP</li> <li>For connecting to connecting plate VAPV-S3</li> <li>Pre-assembled</li> </ul>	<ul style="list-style-type: none"> <li>For valves with ZB solenoid coil: MZBH, MOZBH</li> <li>For valves with ZC solenoid coil: CPE10-M1BH, CPE14-M1BH, MH2, MH3</li> <li>Mounting via central screw</li> </ul>	<ul style="list-style-type: none"> <li>For valves with EB solenoid coil: CPE18, CPE24, MEBH, MOEBH, JMEBH, JMEBDH, JMN2DH</li> <li>Polyvinyl chloride or polyurethane cable</li> <li>Mounting via central screw</li> </ul>
<b>online: →</b>	<a href="#">nebv</a>	<a href="#">nedv</a>	<a href="#">kmyz-2</a>	<a href="#">kmeb-1</a>

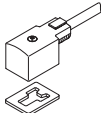

Connecting cables for valves

	 <p><b>Plug sockets with cable KME</b></p>	 <p><b>Plug sockets with cable KMF</b></p>	 <p><b>Plug sockets with cable KMC</b></p>	 <p><b>Connecting cables/plug sockets with cable KMH</b></p>
<b>Electrical connection</b>	Angled socket, square design, 3-pin, type C, open end, 2-wire	Socket	Socket, type A	Socket, 3-pin
<b>Cable length</b>	2.5 ... 10 m	2.5 ... 10 m	2.5 ... 10 m	0.5 ... 5 m
<b>Quick ordering of selected basic designs</b>		★		
<b>Description</b>	<ul style="list-style-type: none"> <li>For valves with E solenoid coil: MEH, MOEH, JMEH</li> <li>Mounting via central screw</li> <li>With polyvinyl chloride cable</li> <li>Ambient temperature -20 ... +80 °C</li> </ul>	<ul style="list-style-type: none"> <li>For valves with F solenoid coil: MFH, MOFH, JMFH, JMFHDH, NVF3, MUFH</li> <li>Mounting via central screw</li> <li>With polyvinyl chloride cable</li> <li>Ambient temperature -20 ... +80 °C</li> </ul>	<ul style="list-style-type: none"> <li>For valves with D solenoid coil: MDH, MODH, JMDH</li> <li>For valves with N1 solenoid coil: MN1H, JMN1H, JMN1DH</li> <li>With polyvinyl chloride cable</li> <li>Mounting via central screw</li> <li>Ambient temperature -20 ... +80 °C</li> </ul>	<ul style="list-style-type: none"> <li>For miniature valves MHA1 and MHP1</li> <li>For fast-switching valves MHA2 and MHP2</li> <li>Mounting via clip</li> <li>Ambient temperature -40 ... +80 °C</li> <li>With polyvinyl chloride cable</li> </ul>
<b>online: →</b>	<a href="#">kme</a>	<a href="#">kmf</a>	<a href="#">kmc</a>	<a href="#">kmh</a>



## Connecting cables for valves

	 <p><b>Connecting cables MHJ9-KMH</b></p>	 <p><b>Plug sockets with cable KMV</b></p>	 <p><b>Connecting cables KRP</b></p>
<b>Electrical connection</b>	Straight socket / straight socket / cable, 2-pin / 2-pin / 4-wire	Socket, type B	Angled socket, 2-pin
<b>Cable length</b>	0.5 ... 2.5 m	2.5 ... 10 m	2.5 ... 5 m
<b>Description</b>	<ul style="list-style-type: none"> <li>• For valves MHJ9</li> <li>• With plug sockets KMH</li> <li>• With control electronics for two valves</li> </ul>	<ul style="list-style-type: none"> <li>• For valves with V solenoid coil</li> <li>• Mounting via central screw M3</li> <li>• With polyvinyl chloride cable</li> <li>• Ambient temperature -20 ... +80 °C</li> </ul>	<ul style="list-style-type: none"> <li>• Plug socket with cable for connecting relay plates (valve terminal CPV10 and CPV14)</li> <li>• Pre-assembled</li> <li>• Mounting via self-tapping central screw</li> </ul>
<b>online: →</b>	<a href="#">mhj9-kmh</a>	<a href="#">kmv</a>	<a href="#">krp</a>



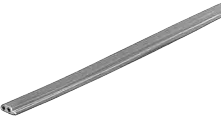

## Connecting cables for valves

	 <p><b>Electrical plug-in bases MHAP-PI</b></p>	 <p><b>Plug sockets with cable KMPPE</b></p>	 <p><b>Connecting cables KMPYE-AIF, KMPYE-5, KMPYE-...</b></p>
<b>Electrical connection</b>	Socket, 2-pin, 3-pin	8-pin	
<b>Cable length</b>	0.5 ... 1 m	2.5 ... 5 m	0.3 ... 5 m
<b>Description</b>	<ul style="list-style-type: none"> <li>• Plug base with cable for connecting individual valves</li> <li>• Pre-assembled</li> <li>• Socket, 2-pin or 3-pin</li> <li>• Mounting via clip</li> </ul>	<ul style="list-style-type: none"> <li>• For proportional pressure regulators MPPE and MPPES</li> <li>• Mounting via union nut M16x0.75</li> <li>• With polyvinyl chloride cable</li> <li>• Ambient temperature -30 ... +80 °C</li> </ul>	<ul style="list-style-type: none"> <li>• Plug socket with cable, screened, 5 m cable, for proportional directional control valves MPYE</li> </ul>
<b>online: →</b>	<a href="#">mhap</a>	<a href="#">kmppe</a>	<a href="#">kmpye</a>

Connecting cables for valve terminals

	 <p><b>Connecting cables/plug sockets with cable NEBV-S1</b></p>	 <p><b>Flat cables KASI</b></p>	 <p><b>Addressing cables KASI-ADR</b></p>	 <p><b>Connecting cables KMP3, KMP4, KMP6</b></p>
<b>Electrical connection</b>	Socket, Sub-D, 25-pin, 44-pin		Straight socket / angled plug / straight socket, 4-pin / 4-pin / 2-pin	Socket, Sub-D, 9-pin, 15-pin, 25-pin, 26-pin
<b>Cable length</b>	0.5 ... 30 m	100 m	2.5 m	2.5 ... 10 m
<b>New</b>	<ul style="list-style-type: none"> <li>Additional versions</li> </ul>			
<b>Description</b>	<ul style="list-style-type: none"> <li>Connecting cable for multi-pin plug connection</li> <li>Pre-assembled</li> </ul>	<ul style="list-style-type: none"> <li>For AS-Interface®</li> <li>2-wire</li> <li>Reverse polarity protected</li> <li>Contact using insulation displacement technology</li> <li>No need to strip cable and wire insulation</li> <li>Two different colours: yellow (preferred for the AS-Interface® network) and black (for auxiliary power supply)</li> </ul>	<ul style="list-style-type: none"> <li>For AS-Interface®</li> <li>For any slaves such as individual valve interface, valve terminal with AS-Interface® connection</li> <li>Reverse polarity protected</li> </ul>	<ul style="list-style-type: none"> <li>Plug socket with cable for multi-pin plug connection</li> <li>Pre-assembled</li> <li>Mounting via union nut, with 2 screws</li> </ul>
<b>online: →</b>	<a href="#">nebv</a>	<a href="#">kasi</a>	<a href="#">kasi-adr</a>	<a href="#">kmp</a>





Connecting cables for valve terminals

	 <p><b>Connecting cables KMPV</b></p>	 <p><b>Connecting cables KVI</b></p>	 <p><b>Connecting cables KVI A</b></p>	 <p><b>Connecting cables VMPA-KMS1, VMPA-KMS2, VMPAL-KM, VMPAL-KMSK</b></p>
<b>Electrical connection</b>	Socket, Sub-D, 15-pin	M9, plug, socket, 5-pin, straight socket/straight plug	Straight plug / straight socket, straight plug / angled socket	Cable with plug
<b>Cable length</b>	5 ... 10 m	0.25 ... 8 m	5 ... 10 m	2.5 ... 10 m
<b>Description</b>	<ul style="list-style-type: none"> <li>Plug socket with cable for multi-pin plug connection</li> <li>Pre-assembled</li> </ul>	<ul style="list-style-type: none"> <li>For fieldbus connection (for valve terminal CPV and installation system CPI)</li> <li>Pre-assembled at both ends</li> <li>Suitable for energy chains</li> </ul>	<ul style="list-style-type: none"> <li>For inputs/outputs (analogue connections)</li> <li>Pre-assembled at both ends</li> <li>4-pin/5-pin round plug</li> <li>Suitable for energy chains</li> </ul>	<ul style="list-style-type: none"> <li>Plug socket with cable for multi-pin connection (to valve terminal MPA)</li> <li>Variant suitable for use with energy chains</li> <li>Cable outlet straight or on the side</li> <li>Pre-assembled at one end</li> <li>With polyvinyl chloride or polyurethane cable</li> </ul>
<b>online: →</b>	<a href="#">kmpv</a>	<a href="#">kvi</a>	<a href="#">kvia</a>	<a href="#">vmpa-kms</a>

## Connecting cables for sensors





	 <p><b>Connecting cables</b> <b>NEBS</b></p>
<b>Electrical connection 1</b>	Straight socket, M12x1, 12-pin, A-coded, straight socket, M12x1, 5-pin, A-coded, socket, square design L1, 4-pin
<b>Electrical connection 2</b>	Straight socket, M12x1, 12-pin, A-coded, open end, 12-wire, open end, 4-wire, open end, 5-wire
<b>Cable length</b>	0.3 ... 10 m
<b>Description</b>	<ul style="list-style-type: none"> <li>• For pressure sensor SPAB</li> <li>• Protection class IP40</li> </ul>
<b>online:</b> →	<a href="#">nebs</a>

## Universal plug connectors

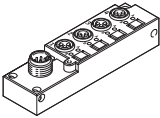

	 <p><b>Distributors</b> <b>NEDY</b></p>	 <p><b>Cable sockets</b> <b>NEFU</b></p>	 <p><b>Plug connectors</b> <b>NECU, NECU-HX</b></p>	 <p><b>Push-in T-connectors</b> <b>NEDU</b></p>
<b>Electrical connection</b>	<p>Straight plug, M8x1, straight plug, M12x1, plug, M8x1 A-coded, EN 61076-2-104, plug, M12x1 A-coded, EN 61076-2-101, open end</p>	<p>Angled socket, RJ45, 4-pin, straight socket, M12x1, 4-pin, D-coded</p>	<p>M8x1, M12x1, socket, Sub-D, 9-pin, straight plug, straight socket, 7/8", 4-pin, straight socket, 7/8", 5-pin, IDC terminal, screw terminal, straight socket, M12x1, 5-pin, B-coded, screenable, socket, screw terminal, screenable, spring-loaded terminal, AIDA push-pull, straight plug, M8x1, 4-pin, straight plug, M12x1, 4-pin, D-coded, screenable, straight plug, M12x1, 5-pin, B-coded, screenable, plug, Sub-D, 9-pin, square design, type A, 3-pin, 4-pin, 5-pin, 7-pin, 8-pin, 2x20-pin, A-coded, R=2.54, pre-assembled, straight plug / insulation displacement connector, straight plug / screw terminal, socket / spring-loaded terminal</p>	<p>Straight socket, M12, 5-pin, A-coded, straight socket, M12x1, 5-pin, A-coded, straight plug, M12x1, 2-pin, A-coded, socket / socket / plug, M12x1 / M12x1 / M12x1, 4-pin / 4-pin / 4-pin, A-coded / A-coded / A-coded</p>
<b>Degree of protection</b>	IP65, IP67, IP68, IP69K	IP20, IP65, IP67, to IEC 60529, in assembled state	IP20, IP40, IP65, IP67	IP65, IP67
<b>Connection cross section</b>			0.08 ... 2.5 mm <sup>2</sup>	
<b>New</b>	<ul style="list-style-type: none"> <li>• New series</li> </ul>			
<b>Description</b>	<ul style="list-style-type: none"> <li>• Collection of signals between field devices (sensors) and double-assigned controller inputs</li> <li>• Distribution of signals between double-assigned controller outputs and field devices (actuators, e.g. valves)</li> </ul>	<ul style="list-style-type: none"> <li>• Cable socket for branching the AS-Interface® network at any required point</li> <li>• Reconnecting AS-Interface® flat cable to 5-pin M12 socket</li> <li>• Reverse polarity protected</li> </ul>	<ul style="list-style-type: none"> <li>• Power supply socket for fieldbus connection</li> <li>• NECU-HX: reconnectable M8 and M12 round plug connectors with Harax® quick connection technology for low-voltage applications</li> <li>• Plug connector and socket for power supply</li> <li>• Can be assembled with any cable lengths</li> </ul>	<ul style="list-style-type: none"> <li>• For fieldbus connection</li> <li>• Branch line for connecting and disconnecting fieldbus components</li> </ul>
<b>online:</b> →	<a href="#">nedy</a>	<a href="#">nefu</a>	<a href="#">necu</a>	<a href="#">nedu</a>



Universal plug connectors

	 <b>Multi-pin plug distributors NEDU</b>	 <b>Plug connectors SEA</b>	 <b>Cable distributors ASI-KVT</b>	 <b>Cable sockets ASI-SD</b>
<b>Electrical connection</b>	Straight socket, M8, 3-pin, straight plug, M12x1, 8-pin	M8x1, M12x1, M12x1 round plug connector, type A, 3-pin, 4-pin, 5-pin, straight plug / solder connection, straight plug / insulation displacement connector, straight plug / screw terminal, angled socket / screw terminal		Straight socket, screw terminal, 2-pin, 4-pin
<b>Degree of protection</b>	IP68	IP65, IP67	IP65	IP65, IP67
<b>Connection cross section</b>		0.08 ... 0.75 mm <sup>2</sup>	1.5 mm <sup>2</sup>	0.75 ... 1.5 mm <sup>2</sup>
<b>Description</b>	<ul style="list-style-type: none"> <li>• Multi-pin plug distributor</li> <li>• Particularly compact</li> </ul>	<ul style="list-style-type: none"> <li>• Sensor plug and socket for inputs/outputs</li> <li>• Can be assembled with any cable lengths</li> </ul>	<ul style="list-style-type: none"> <li>• Flat cable distributor for branching or for reconnecting AS-Interface® flat cables</li> <li>• Reverse polarity protected</li> </ul>	<ul style="list-style-type: none"> <li>• For AS-Interface®</li> <li>• Flat-cable socket for connecting AS-Interface® stations to the AS-Interface® bus system</li> <li>• M12 connection</li> <li>• Reverse polarity protected</li> <li>• Detachable connection</li> </ul>
<b>online:</b> →	<a href="#">nedu</a>	<a href="#">sea</a>	<a href="#">asi-kvt</a>	<a href="#">asi-sd</a>



Plug connectors for control systems

	 <b>Plug connectors NECC</b>	 <b>Plug connectors PS1-SAC, PS1-ZC</b>	 <b>Plug connectors FBS-SUB-9-WS</b>
<b>Electrical connection</b>	Sub-D / screw terminal, 9-pin / 9-pin	Socket / terminal strip, 10-pin / 10-pin, 10-pin / 30-pin	5-pin, type A, M12x1, straight plug / screw terminal
<b>Connection cross section</b>	0.2 ... 2.5 mm <sup>2</sup>	0.08 ... 0.75 mm <sup>2</sup>	0.75 mm <sup>2</sup>
<b>Degree of protection</b>	IP40		IP40
<b>Description</b>	<ul style="list-style-type: none"> <li>• Encoder plug for motor controllers CMMS-ST, CMMS-AS</li> <li>• Plug for multi-axis controllers CMXR for interface housing CAMI-C, 11-pin</li> <li>• Plug for multi-axis controllers CMXR and for modular controllers CECX for peripheral modules</li> <li>• 2-pin, 4-pin, 6-pin, 8-pin, 11-pin, 18-pin</li> </ul>	<ul style="list-style-type: none"> <li>• For power supply</li> <li>• Cable connection using clamping technology</li> <li>• Individually or as a set</li> </ul>	<ul style="list-style-type: none"> <li>• Plug connector for bus connection CAN bus and PROFIBUS</li> <li>• Cable connection 2x horizontal or 2x vertical</li> <li>• Printed circuit terminal block with screw connector</li> </ul>
<b>online:</b> →	<a href="#">necc</a>	<a href="#">ps1</a>	<a href="#">fbs-sub-9-ws</a>

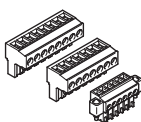

## Plug connectors for control systems

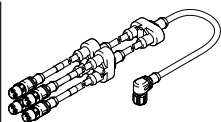
	 <b>Plug connectors</b> <b>FBS-RJ45</b>	 <b>Plug assortment</b> <b>NEKM</b>
<b>Electrical connection</b>	5-pin, type A, M12x1, straight plug / screw terminal	2 ... 9-pin, screw connector
<b>Connection cross section</b>	0.75 mm <sup>2</sup>	0.2 ... 2.5 mm <sup>2</sup>
<b>Degree of protection</b>	IP65, IP67, to IEC 60529	
<b>Description</b>	<ul style="list-style-type: none"> <li>Ethernet plug with 8-pin RJ45 connection</li> <li>High transmission quality</li> <li>Detachable connection</li> </ul>	<ul style="list-style-type: none"> <li>For motor cable, encoder cable, power supply, reference switch, STO safety function</li> <li>Comprising plug connector for power supply and plug connector for motor connection</li> </ul>
<b>online: →</b>	<a href="#">fbs-rj</a>	<a href="#">nekm</a>



## Plug connectors for valves

	 <b>Adapters</b> <b>NEFV</b>	 <b>Plug sockets</b> <b>MSSD</b>
<b>Electrical connection</b>		Socket, angled socket, angled socket, square design, 3-pin, type C, socket, to EN 175301-803, type C, square design, square design MSC, square design MSEB, square design MSF, square design MSN1, square design MSN2, square design MSV, to DIN EN 175301-803, to DIN EN 61984, type A, type B, type C, 3-pin, 4-pin
<b>Electrical connection 1 and 2, function</b>	Field device side, controller side, analogue output module (green), digital input module (white), analogue input module (yellow), digital output module (red)	
<b>Electrical connection 1 and 2, connection type</b>	Socket, 4x plug	
<b>Electrical connection 1 and 2, cable outlet</b>	Straight, angled	
<b>Electrical connection 1 and 2, design</b>	Round	
<b>Electrical connection 1 and 2, connection technology</b>	M12x1, A-coded to EN 61076-2-101	
<b>Electrical connection 1 and 2, number of pins/wires</b>	8	
<b>Connection cross section</b>		0.25 ... 1.5 mm <sup>2</sup>
<b>Degree of protection</b>	IP65, IP67	IP50, IP65, IP67, to IEC 60529, in assembled state
<b>Quick ordering of selected basic designs</b>		★
<b>Description</b>	<ul style="list-style-type: none"> <li>Adapter for connecting a proportional valve to the control system</li> </ul>	<ul style="list-style-type: none"> <li>For valves with F, D, N1, V, E, EB, N2, Y, Z, ZB, ZC, MD-2 and MH-2 solenoid coils</li> <li>For connecting individual valves</li> <li>Cable connection using clamping screws, insulation displacement technology or push-in connector</li> <li>Optionally with LED display</li> </ul>
<b>online: →</b>	<a href="#">nefv</a>	<a href="#">mssd</a>



Plug connectors for valves

			
	<b>Soldering base PCBC</b>	<b>Multi-pin plug sockets NECA</b>	<b>Angled plug sockets MPPE-3-B</b>
<b>Electrical connection</b>	2-pin	Socket, Sub-D, 9-pin	Angled socket, 8-pin, solderable
<b>Connection cross section</b>		0.34 ... 1 mm <sup>2</sup>	0.75 mm <sup>2</sup>
<b>Degree of protection</b>	IP40	IP65, to IEC 60529	IP67
<b>Description</b>	<ul style="list-style-type: none"> <li>For mounting miniature valves MHA1 and MHP1 on a PCB with plug connection underneath (-PI)</li> </ul>	<ul style="list-style-type: none"> <li>For soft-start/quick exhaust valves MS6-SV, MS series</li> <li>Electrical connection via 9-pin Sub-D, 9-pin screw terminal</li> </ul>	<ul style="list-style-type: none"> <li>For proportional pressure regulators MPPE and MPPES</li> <li>Mounting via union nut</li> </ul>
<b>online:</b> →	<a href="#">pcbc</a>	<a href="#">neca</a>	<a href="#">mppe-3-b</a>



Plug connectors for valves

			
	<b>Time delay inserts MFZ</b>	<b>Illuminating seals MC-LD, ME-LD, MEB-LD, MF-LD, MV-LD</b>	<b>Indicator inserts MCL, MCLZ, MFL, MFLZ</b>
<b>Electrical connection</b>	For connector socket or device plug, type F	Square design MSC, square design MSE, square design MSEB, square design MSF, square design MSV, to DIN EN 175301-803, type A, type B, type C	Plug, to DIN 43650
<b>Degree of protection</b>	IP64	IP65	IP65
<b>Description</b>	<ul style="list-style-type: none"> <li>Electronic timer with adjustable time delay between 0 ... 10 s</li> <li>For mounting between the solenoid coil and connector socket or plug</li> </ul>	<ul style="list-style-type: none"> <li>The seal is illuminated yellow when the power is switched on</li> <li>For mounting between the solenoid coil and connector socket or device plug</li> <li>For F, D, N1, V, E and EB solenoid coils</li> </ul>	<ul style="list-style-type: none"> <li>Variant with integrated protective circuit</li> <li>For mounting between the solenoid coil and connector socket or device plug</li> <li>With yellow LED display</li> </ul>
<b>online:</b> →	<a href="#">mfz</a>	<a href="#">mc-ld</a>	<a href="#">mcl</a>

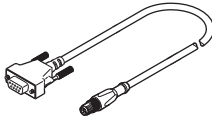

## Plug connectors for valve terminals

	 <b>Plug sockets FBSD</b>	 <b>Plug sockets NTSD</b>	 <b>T-adapters FB-TA</b>	 <b>Bus connections FBA-1, FBA-2</b>
<b>Electrical connection</b>	M12x1, type A, 4-pin, 5-pin, angled socket / screw terminal, straight socket / screw terminal	Straight socket, angled socket, screw terminal, 4-pin, 5-pin, straight plug / screw terminal	5-pin, plugs / sockets, M12x1 / M12x1	Straight socket / straight plug, Sub-D / M12x1, Sub-D / -, 9-pin / 5-pin, straight socket / plug and socket
<b>Degree of protection</b>	IP67	IP67	IP67	IP40, IP65, to IEC 60529
<b>Description</b>	<ul style="list-style-type: none"> <li>• For fieldbus connection</li> <li>• Straight or angled design</li> <li>• Can be assembled with any cable lengths</li> </ul>	<ul style="list-style-type: none"> <li>• Straight or angled design</li> <li>• For power supply</li> <li>• Can be assembled with any cable lengths</li> </ul>	<ul style="list-style-type: none"> <li>• For fieldbus connection</li> </ul>	<ul style="list-style-type: none"> <li>• Can be assembled with any cable lengths</li> </ul>
<b>online: →</b>	<a href="#">fbs</a>	<a href="#">ntsd</a>	<a href="#">fb-ta</a>	<a href="#">fba</a>



## Plug connectors for valve terminals

	 <b>Plug connectors FBS-SUB</b>	 <b>Sensor sockets, angled plug sockets SIE-GD, SIE-WD</b>	 <b>Cover cap ISK</b>
<b>Electrical connection</b>	M12x1, type A, 5-pin, straight plug / screw terminal	M12x1, straight socket, angled socket, 4-pin	
<b>Degree of protection</b>	IP65, IP67 to IEC 60529, in assembled state	IP67	IP65
<b>Description</b>	<ul style="list-style-type: none"> <li>• Variants for PROFIBUS DP, INTERBUS nodes CPX and CPV, CC-Link CPX and CPV, CPX-FEC</li> <li>• Position of DIL switches can be read externally</li> <li>• Easy assembly</li> </ul>	<ul style="list-style-type: none"> <li>• For customised assembly of cables</li> <li>• Pin adapter for fieldbus connection</li> <li>• With screw terminals</li> <li>• Straight or angled design</li> </ul>	<ul style="list-style-type: none"> <li>• For sealing unused connections/openings</li> <li>• Thread M8, M12</li> </ul>
<b>online: →</b>	<a href="#">fbs-sub</a>	<a href="#">sie-gd</a>	<a href="#">isk</a>



## Plug connectors for valve terminals

	 <b>Plug sockets, plug connectors SD-SUB</b>	 <b>Bus connections FBSD-KL</b>
<b>Electrical connection</b>	Plug, Sub-D, 25-pin	Angled socket / screw terminal, 5-pin / 5-pin
<b>Degree of protection</b>	IP65	IP20
<b>Description</b>	<ul style="list-style-type: none"> <li>• Socket for multi-pin plug connection</li> <li>• Plug for inputs/outputs</li> <li>• Can be assembled with any cable lengths</li> </ul>	<ul style="list-style-type: none"> <li>• 5-pin angled socket, 5-pin screw terminal</li> </ul>
<b>online: →</b>	<a href="#">sd-sub</a>	<a href="#">fbzd-kl</a>

Plug connectors for sensors

	 <b>Angled plug sockets</b> <b>PEV...-WD</b>	 <b>Plug sockets</b> <b>SD-4-WD</b>
<b>Electrical connection</b>	Angled socket, 4-pin	
<b>Degree of protection</b>	IP65	IP65, to IEC 60529
<b>Description</b>	<ul style="list-style-type: none"> <li>• For pressure switch PEV</li> <li>• 15 ... 30, 180 V DC, 230 V AC</li> <li>• Optionally with LED display</li> <li>• Angled design</li> </ul>	<ul style="list-style-type: none"> <li>• For swivel module DSMI</li> <li>• Angled design</li> </ul>
<b>online:</b> →	<a href="#">pev*wd</a>	<a href="#">sd-4-wd</a>

## Pneumatic and electropneumatic controllers

	 <b>Steppers</b> TAA, TAB	 <b>Memory modules</b> SBA-2 N	 <b>Pulse oscillators</b> VLG
<b>Pneumatic connection</b>	Barbed connections for plastic tubing NW3	Barbed connections for plastic tubing NW3	G1/8, G1/4
<b>Type of mounting</b>	On mounting frame	On mounting frame	Through-hole in housing
<b>Nominal width</b>	2 mm	3 mm	3.5 mm, 7 mm
<b>Standard nominal flow rate</b>	60 l/min	70 l/min	120 l/min, 600 l/min
<b>Description</b>	<ul style="list-style-type: none"> <li>• For ensuring a logical program sequence</li> <li>• Poppet valve with integrated AND as well as OR element</li> </ul>	<ul style="list-style-type: none"> <li>• For input logic operations</li> <li>• For simplifying the design and installation of pneumatic controllers</li> </ul>	<ul style="list-style-type: none"> <li>• For generating infinitely adjustable signals in controllers</li> <li>• For high-speed cylinder movements of diaphragm cylinders, single- and double-acting cylinders</li> </ul>
<b>online: →</b>	<a href="#">taa</a>	<a href="#">sba</a>	<a href="#">vlg</a>

## Software tool

**CODESYS**







CODESYS for standardised programming of embedded devices according to IEC 61131-3. It makes your life easier with simple commissioning, fast programming and parameterisation.

**Advantages**



- Hardware-neutral software platform for quick and easy configuration, programming and commissioning of pneumatic and electric automation solutions
- Extensive module libraries for single- or multi-axis positioning motions
- The IEC 61131-3 standard means that CODESYS is flexible and open for all types of control tasks.
- Modular: offline and online functions as well as components for hardware configuration and visualisation.
- User-friendly IEC function block extension.
- Re-use of existing application parts.

The parameterisation software can be found on the website under Support › Support Portal › enter search term.



## Electronic controllers

	 <b>Controllers</b> CECC-D, CECC-LK, CECC-S	 <b>Control systems</b> CECX-X-C1, CECX-X-M1	 <b>Input/output modules</b> CECX-D-E8A, CECX-A-4E4A	 <b>Input modules</b> CECX-D-16E, CECX-A-4E-V
<b>Operating voltage</b>	19.2–30 VDC, 20.4–30 VDC	19.2–30 VDC	19.2–30 VDC	19,2 ... 30 VDC
<b>CPU data</b>	400 MHz processor	64 DRAM, 400 MHz processor	64 MB DRAM, 400 MHz processor	64 MB DRAM, 400 MHz processor
<b>Fieldbus interface</b>	CAN-Bus	CAN-Bus		
<b>Ethernet, connector plug</b>	RJ45	RJ45, socket, 8-pin		
<b>Description</b>	<ul style="list-style-type: none"> <li>• Compact programmable logic controller</li> <li>• Programming with CODESYS to IEC 61131-3</li> <li>• 12 digital inputs, 8 digital outputs, additionally 2 high-speed counters up to 250 kHz</li> <li>• Ethernet 10/100 Mbit/s</li> <li>• USB interface for data transfer</li> <li>• CECC-LK with CANopen, IO-Link®, I-Port and Modbus TCP protocol</li> </ul>	<ul style="list-style-type: none"> <li>• Modular master controller with CODESYS or motion controller with CODESYS and SoftMotion.</li> <li>• Programming to standard IEC 61131-3</li> <li>• Three plug-in slots for optional modules</li> <li>• Optional: communication module for PROFIBUS</li> </ul>	<ul style="list-style-type: none"> <li>• Digital modules: 6 or 8 digital inputs and 8 digital outputs</li> <li>• Analogue modules for voltage: 4 analogue voltage inputs and 4 analogue voltage outputs</li> <li>• Analogue modules for current: 4 analogue current inputs and 4 analogue current outputs</li> <li>• Address setting function, short circuit monitoring function for outputs, debounce function, interrupt function, sensor failure detection function</li> </ul>	<ul style="list-style-type: none"> <li>• Digital modules: 16 digital inputs</li> <li>• Analogue modules for voltage: 4 analogue voltage inputs</li> <li>• Temperature input modules: 4 or 6 temperature inputs</li> </ul>
<b>online:</b> →	<a href="#">cecc</a>	<a href="#">cecx-x</a>	<a href="#">cecx</a>	<a href="#">cecx</a>





## Electronic controllers

	 <b>Output modules</b> CECX-D-14 A-2, CECX-A-4 A-V	 <b>Encoder interfaces</b> CECX-C-2G	 <b>Bus interfaces</b> CECX-F-PB-S-V, CECX-F-PB-V1, CECX-B-CO
<b>Operating voltage</b>	24 +25% / -15% VDC	19.2–30 VDC	19.2–30 VDC
<b>CPU data</b>			
<b>Fieldbus interface</b>			CAN-Bus, Profibus-Master DP-V1, Profibus-Slave DP-V1
<b>Ethernet, connector plug</b>			
<b>Description</b>	<ul style="list-style-type: none"> <li>• Digital modules: 14 digital outputs</li> <li>• Analogue modules: 4 analogue voltage outputs</li> </ul>	<ul style="list-style-type: none"> <li>• Displacement encoder function</li> <li>• Pulse counter</li> <li>• Speed measurement function</li> <li>• Shaft encoder monitoring function</li> <li>• Counter reading latching function</li> <li>• Sensor break monitoring</li> <li>• Status display function</li> </ul>	<ul style="list-style-type: none"> <li>• PROFIBUS master DP-V1</li> <li>• Connection via CAN Bus to the modular controller</li> <li>• For connecting decentralised peripheral modules in series</li> </ul>
<b>online:</b> →	<a href="#">cecx</a>	<a href="#">cecx</a>	<a href="#">cecx</a>

## Electronic controllers



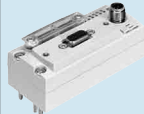

		
	<b>Electrical interfaces CECX-C-2S1</b>	<b>AS-Interface® module CESA</b>
<b>Operating voltage</b>	9,2 ... 30 V DC	AS-Interface® voltage 30 VDC
<b>CPU data</b>		
<b>Fieldbus interface</b>		CANopen Device Specification CiA DS-301, PROFIBUS to DIN 19245 Part 3
<b>Ethernet, connector plug</b>	8-pin	
<b>Description</b>	<ul style="list-style-type: none"> <li>For extending the controller with two RS232 serial interfaces</li> </ul>	<ul style="list-style-type: none"> <li>AS-Interface® master gateway</li> <li>Duplicate address recognition</li> <li>Direct operation via pushbuttons</li> <li>Graphic display</li> <li>Comprehensive diagnostics via LED and display</li> <li>Specification 3.0</li> </ul>
<b>online: →</b>	<a href="#">cecx</a>	<a href="#">cesa</a>

## Electrical peripherals



			 <b>New</b>	
	<b>Terminal CPX-P</b>	<b>Input modules for installation system CTEL CTSL</b>	<b>Fieldbus modules CTEU</b>	<b>CPI installation systems CTEC</b>
<b>Max.no. of inputs</b>	Digital 512, analogue 32	16	128	128
<b>Max.no. of outputs</b>	Digital 512, analogue 32		128	128
<b>Number of module positions</b>	10		32	Max. 4 installation strings, max. 4 CP modules per string
<b>Electrical actuation</b>	Fieldbus, integrated controller	IO-Link, I-Port	CANopen, DeviceNet, CC-Link, PROFIBUS, EtherCAT, I-Port	Fieldbus, integrated controller
<b>New</b>			<ul style="list-style-type: none"> <li>EtherNet/IP bus node</li> </ul>	
<b>Description</b>	<ul style="list-style-type: none"> <li>Use of matching remote I/O and valve terminals in a control cabinet</li> <li>Combination with modules of the electrical terminal CPX, which enables use for hybrid applications</li> <li>Unique modular structure</li> <li>Comprehensive integrated diagnostic and maintenance functions</li> </ul>	<ul style="list-style-type: none"> <li>For installation system CTEL</li> <li>For recording sensor input signals</li> <li>Display of the input statuses for each input signal via an assigned LED</li> <li>Diagnostic LED for short circuit/overload in sensor supply</li> </ul>	<ul style="list-style-type: none"> <li>For valve terminals VTUB-12, VTUG, MPA-L, CPV, VTOC</li> <li>Can be expanded into installation systems CTEL</li> <li>Fieldbus-typical LEDs, interfaces and switching elements</li> <li>Isolated power supply for electronics and valves</li> </ul>	<ul style="list-style-type: none"> <li>CPX master module for four CPI strings</li> <li>Combination of centralised and decentralised installation possible</li> <li>Decentralised pneumatic components and sensors for fast processes</li> <li>Can be connected to valve terminal CPV, MPA-S, CPV-SC</li> </ul>
<b>online: →</b>	<a href="#">cpx-p</a>	<a href="#">ctsl</a>	<a href="#">cteu</a>	<a href="#">ctec</a>





Electrical peripherals

	 <b>Terminal CPX</b>	 <b>Electrical interface CPX-CTEL</b>	 <b>Measuring modules CPX-CMIX</b>	 <b>AS-Interface® components ASI, CACC</b>
<b>Max.no. of inputs</b>	Digital 512, analogue 32	256		4, 8
<b>Max.no. of outputs</b>	Digital 512, analogue 18	256		8
<b>Number of module positions</b>	Max. 9 electric input/output modules	Max. 4 modules with I-Port interface	9	
<b>Electrical actuation</b>	Fieldbus, integrated controller			AS-Interface®
<b>Description</b>	<ul style="list-style-type: none"> <li>Automation platform</li> <li>Open to all common fieldbus protocols and Ethernet</li> <li>Integrated diagnostic and maintenance functions</li> <li>Can be used as stand-alone remote I/O or with valve terminals MPA-S, MPA-L, VTSA/VTSA-F</li> <li>Choice of polymer or metal housing with individual linking</li> </ul>	<ul style="list-style-type: none"> <li>CPX-CTEL master module with 4 I-Port connections</li> <li>Decentralised pneumatic components and sensors for fast processes</li> <li>Standardised M12 connections</li> </ul>	<ul style="list-style-type: none"> <li>Pneumatics and electrics – movement and measurement on one platform</li> <li>Innovative measurement technology for piston rod drives, rodless drives, rotary drives</li> <li>Control via fieldbus</li> <li>Remote maintenance, remote diagnostics, web server, SMS and e-mail alerts are all possible via TCP/IP</li> <li>Modules can be quickly exchanged and expanded without altering the wiring</li> </ul>	<ul style="list-style-type: none"> <li>Accessories for the AS-Interface® installation system</li> <li>Modules for actuating individual valves ASI-EVA</li> <li>Cable distributor ASI-KVT</li> <li>Addressing device ASI-PRG-ADR</li> <li>Compact I/O modules (IP65, IP67)</li> </ul>
<b>online: →</b>	<a href="#">cpx</a>	<a href="#">cpx-ctel</a>	<a href="#">cpx-cmix</a>	<a href="#">as-interface</a>



Operator units

	 <b>Operator units CDPX</b>	 <b>Simulators CDSM</b>	 <b>Operator units CPX-MMI</b>
<b>Display</b>	Colour TFT		128x64 Pixel, LCD display, with background illumination
<b>Display size</b>	13.3", 7", 4.3", 10.4"		
<b>Recipe memory</b>	32000 byte		
<b>Display resolution</b>	480x272 Pixel, SVGA, 800x600 Pixel, WVGA, 800x480 Pixel, WXGA, 1280x800 Pixel		
<b>Ethernet interface</b>	RJ45 10/100 MBd		
<b>Description</b>	<ul style="list-style-type: none"> <li>Powerful processors combined with wide-screen technology</li> <li>Remote access, remote control</li> <li>FTP and HTTP servers</li> <li>Open for web and multimedia applications</li> </ul>	<ul style="list-style-type: none"> <li>Straightforward design of human-machine dialogues</li> <li>Semi-graphical display of process values makes them easier to read</li> <li>Suitable for commissioning the following motor controllers: CMMO-ST, CMM-AS, CMM-AS, CMM-AS</li> <li>To simulate input and output signals during commissioning</li> </ul>	<ul style="list-style-type: none"> <li>Data polling, configuration and diagnostic functions for terminal CPX</li> <li>Connection to the CPX bus nodes or control block via a pre-assembled M12 cable</li> <li>3 function keys, 4 arrow keys</li> </ul>
<b>online: →</b>	<a href="#">cdpx</a>	<a href="#">cdsm</a>	<a href="#">cpx-mmi</a>

## Software

	 <b>Operator package GSIB</b>	 <b>Operator package P. BP</b>	 <b>Software GSPF</b>
<b>Description</b>	<ul style="list-style-type: none"> <li>Information software and documentation for motor controllers CMMD-AS, CMMS-AS, CMMP-AS, CMMS-ST</li> <li>The operator package contains a CD-ROM with user documentation for motor controller and configuration software FCT (Festo Configuration Tool) and a brief description</li> </ul>	<ul style="list-style-type: none"> <li>Information software and documentation for motor controllers CMMP-AS and SFC-DC, handling module HSP/HSW and motor unit MTR-DCI</li> <li>The operator package contains a CD-ROM with user documentation for motor controller and configuration software FCT (Festo Configuration Tool) and a brief description</li> </ul>	<ul style="list-style-type: none"> <li>Programming software and documentation for motor controller CMMP-AS with additional functions for cam disc functionality</li> <li>Software for configuring, programming, commissioning and maintaining the controller CECC</li> <li>Programming software for creating custom application programs for safety systems CMGA</li> <li>Operating software for configuring, programming and for AS-Interface® diagnostics with serial connecting cable</li> <li>The software package contains a CD-ROM with user documentation for motor controllers</li> </ul>
<b>online:</b> →	<a href="#">gsib</a>	<a href="#">software</a>	<a href="#">gspf</a>

## Software

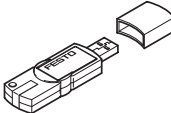
	 <b>Software and manual P. SW</b>	 <b>Software licence GSLO</b>	 <b>Software (FluidDraw P5®) GSWF-P5</b>
<b>Description</b>	<ul style="list-style-type: none"> <li>For configuring the terminal CPX, for parameterising the CPX modules, for programming the controller CPX-FEC</li> <li>Software for checkbox CHB-C for image evaluation, display, protocol and adaptation of the I/O parameters</li> <li>Software for Checkbox CHB-C for the complete analysis of recognition processes</li> </ul>	<ul style="list-style-type: none"> <li>For enabling tools on the compact vision system SBOC-Q/SBOI-Q</li> </ul>	<ul style="list-style-type: none"> <li>Quick and easy creation of pneumatic circuit diagrams</li> <li>Comprehensive library of pneumatic and electrical symbols</li> <li>User-specific product databases and translation tables</li> <li>Terminal plans, cable diagrams, cable lists, parts lists</li> <li>Dimensioning function for preparing simple control cabinet and system layouts</li> <li>Consistent equipment identification</li> <li>Multi-level project tree</li> </ul>
<b>online:</b> →	<a href="#">software</a>	<a href="#">gslo</a>	<a href="#">gswf-p5</a>



## Learning systems

	 <b>EduTrainer Universal</b> <b>D: ET-SPS</b>
<b>Description</b>	<ul style="list-style-type: none"><li>• PLC EduTrainer® support system for use in teaching and training</li><li>• Equipped with PLCs from different manufacturers</li><li>• Two series: universal and compact</li><li>• Equipped with 19" simulation modules</li><li>• Individually configurable or pre-assembled</li></ul>
<b>online:</b> →	<a href="#">edutrain</a>





## Tools

	 <p><b>Clip fix tool AGTC</b></p>
<b>Valve function</b>	2/2-way, monostable, closed
<b>Type of actuation</b>	Mechanical
<b>Operating pressure</b>	2 ... 6 bar
<b>Pneumatic connection 1</b>	Female thread G1/4
<b>Description</b>	<ul style="list-style-type: none"> <li>• Pneumatic mounting device for clips of various design</li> <li>• Material recommendation for polymer clip adapter: e. g. PBT, PE-UHMW or POM</li> </ul>
<b>online: →</b>	<a href="#">agtc</a>



## Reservoirs

	 <p><b>Air pressure reservoirs VZS</b></p>	 <p><b>Air pressure reservoirs CRVZS</b></p>
<b>Volume</b>	20 l	0,1 l, 0,4 l, 0,75 l, 10 l, 2 l, 20 l, 5 l
<b>Information on materials: air reservoir</b>	Powder-coated steel	High-alloy stainless steel
<b>Conforms to</b>	EN 286-1	AD 2000
<b>Condensate drain connection</b>	G3/8	G3/8
<b>Description</b>	<ul style="list-style-type: none"> <li>• Can be used to compensate pressure fluctuations, and act as accumulators in the event of sudden air consumption</li> <li>• Provision of large quantities of compressed air for supplying fast pulsing drives</li> <li>• With connection for condensate drain</li> <li>• Conforms to the requirements of Directive 2014/29/EC and EN 286-1</li> <li>• Operating media compressed air, vacuum</li> </ul>	<ul style="list-style-type: none"> <li>• Corrosion resistant</li> <li>• Compensation of pressure fluctuations and as accumulators in the event of sudden air consumption</li> <li>• Provision of large volumes of compressed air for supplying fast pulsing drives</li> <li>• With port for condensate drain in some cases</li> <li>• See supplementary information on food-safe materials at <a href="http://www.festo.com/sp">www.festo.com/sp</a> &gt; Certificates</li> <li>• Designs to EU Pressure Equipment Directive EN 286-1</li> <li>• Operating medium compressed air, vacuum</li> </ul>
<b>online: →</b>	<a href="#">VZS</a>	<a href="#">CRVZS</a>



Silencers

	 <b>Silencers AMTE</b>	 <b>Silencers U</b>	 <b>Silencers AMTC</b>	 <b>Silencers UC</b>
<b>Information on materials: silencer insert</b>	Bronze	PE, Bronze	PE	PE
<b>Pneumatic connection</b>	G1, G1/2, G1/4, G1/8, G3/4, G3/8, M3, M5, NPT1/2-14, NPT1/4-18, NPT1/8-27, NPT3/8-18, UNF10-32	G1, G1/2, G1/4, G1/8, G3/4, G3/8, NPT3/4-14, PK-3, PK-4	Cartridge 10	G1/4, G1/8, G3/8, M5, M7, QS-10, QS-3, QS-4, QS-6, QS-8
<b>Noise level</b>	55 ... 95 dB(A)	70 ... 85 dB(A)	58 dB(A)	58 ... 68 dB(A)
<b>Quick ordering of selected basic designs</b>	★	★		
<b>Description</b>	<ul style="list-style-type: none"> <li>• Long or short design</li> <li>• Metal design</li> <li>• Operating medium: compressed air</li> </ul>	<ul style="list-style-type: none"> <li>• Compact design, polymer or die-cast</li> <li>• Barbed connector or threaded connection</li> <li>• Operating medium compressed air</li> </ul>	<ul style="list-style-type: none"> <li>• For valve terminal VTUB-12</li> <li>• Attached via pin (spring clip, included in the scope of delivery of the valve)</li> <li>• Polymer version</li> <li>• Operating medium compressed air</li> </ul>	<ul style="list-style-type: none"> <li>• Threaded connection or push-in sleeve for push-in fitting QS</li> <li>• Polymer version</li> <li>• Operating medium compressed air</li> </ul>
<b>online: →</b>	<a href="#">amte</a>	<a href="#">u</a>	<a href="#">amtc</a>	<a href="#">uc</a>



Silencers

	 <b>Silencers UO</b>	 <b>Silencers UOS-1, UOS-1-LF</b>	 <b>Silencers UOM, UOMS</b>
<b>Information on materials: silencer insert</b>	PE	PE	PU foam
<b>Pneumatic connection</b>	G1/4, G1/8, M7	G1	G1/4, G3/8
<b>Noise level</b>			
<b>Description</b>	<ul style="list-style-type: none"> <li>• Special open minimal resistance silencer</li> <li>• For vacuum generators</li> <li>• Facilitates trouble-free operation of the vacuum generator</li> <li>• Operating medium compressed air</li> </ul>	<ul style="list-style-type: none"> <li>• Safety silencer for MS6-SV, MS series</li> <li>• Operating medium compressed air</li> </ul>	<ul style="list-style-type: none"> <li>• Special open minimal resistance silencer</li> <li>• For vacuum generators</li> <li>• Facilitates trouble-free operation of the vacuum generator</li> <li>• Silencer extension for extending the silencer for further noise reduction</li> <li>• Operating medium: compressed air</li> </ul>
<b>online: →</b>	<a href="#">uo</a>	<a href="#">uos</a>	<a href="#">uom</a>



## Air guns

		
	<b>Air guns</b> LSP	<b>Air nozzles</b> LPZ
<b>Exhaust-air function</b>	Metered blowing	
<b>Pneumatic connection</b>	Female thread G1/4	Male thread M12x1.25
<b>Information on materials: housing</b>	Wrought aluminium alloy, reinforced PA6	Aluminium, brass, chrome-plated and nickel-plated die-cast zinc
<b>Description</b>	<ul style="list-style-type: none"> <li>• Precise, infinitely variable, lever-operated flow metering</li> <li>• Interchangeable nozzles</li> <li>• Operating medium compressed air</li> </ul>	<ul style="list-style-type: none"> <li>• With protective air shield or silencer</li> <li>• Targeted, strong air jet or powerful, focused air jet</li> <li>• Low noise level</li> <li>• Operating medium compressed air</li> </ul>
<b>online:</b> →	<a href="#">lsp</a>	<a href="#">lpz</a>

## Pneumatic indicators

		
	<b>Pressure indicators</b> OH	<b>Pneumatic terminals, end clamps, distributors</b> LT, LTE, LTV
<b>Design</b>	Indicator plate with 16 pressure indicators, indicating pin with spring return, reflection principle	
<b>Size</b>	8, 10, 22	
<b>Operating pressure</b>	-1 ... 8 bar	0.1 ... 8 bar
<b>Pneumatic connection</b>	Barbed connector PK-3, G1/8	Barbed connector PK-3, PK-4
<b>Description</b>	<ul style="list-style-type: none"> <li>• Visual indicator</li> <li>• Indicator colours: red, blue, yellow or green</li> <li>• Aluminium or polymer</li> <li>• Operating medium compressed air</li> </ul>	<ul style="list-style-type: none"> <li>• Pneumatic terminal for checking incoming and outgoing signals at the controller input and output</li> <li>• Up to 15 distributor pieces with common air supply, for easy connection</li> <li>• Brass, polymer</li> <li>• Operating medium compressed air</li> </ul>
<b>online:</b> →	<a href="#">oh</a>	<a href="#">lt</a>

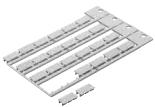
## Inscription systems

		
	<b>Inscription labels</b> ASLR, BZ, HWF, IBS, KM, KMC, MH, SBS, SIEZ	<b>Inscription label holders</b> ST, CPV10-VI-ST, CPV14-VI-ST, CPV18-VI-ST, CPVSC1-ST, CPX-ST, IBT, MN2H-BZT, MVH-BZ, VMPA1-ST
<b>Type of mounting</b>	Inscription label is pressed onto a cable, pressed into a holder or carrier, through-hole	Plug-on, snap-in, clip-on
<b>Width</b>	4.5 ... 11 mm	12 mm
<b>Height</b>	9 ... 20 mm	2 mm
<b>Description</b>	<ul style="list-style-type: none"> <li>• For labelling items</li> <li>• Can be inserted in holders or carriers on suitably equipped components</li> </ul>	<ul style="list-style-type: none"> <li>• Holder for inscription labels</li> <li>• For components without pre-assembled carriers</li> </ul>
<b>online:</b> →	<a href="#">aslr</a>	<a href="#">ascf</a>

## Control technology and remote I/O

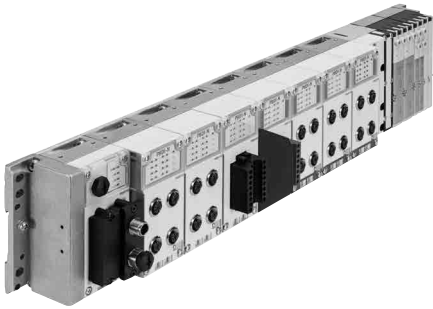



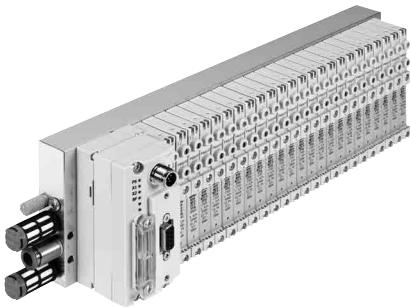

- Electronic controllers and remote I/Os including electrical peripherals for standard and potentially explosive atmospheres.  
→ [www.festo.com/pa/control](http://www.festo.com/pa/control)

## Valve terminals





- Valve modules with electrical multi-pin, individual, or fieldbus connections or integrated control, with or without electrical inputs and outputs  
→ [www.festo.com/pa/valveterminals](http://www.festo.com/pa/valveterminals)

Pilot valves



	 <b>Solenoid valves VSNC</b>	 <b>Standards-based valves, NAMUR (VDI/VDE 3845) NVF3</b>	 <b>Solenoid valves VOFC</b>	 <b>Solenoid valves VOFD</b>
<b>Valve function</b>	5/2-way double solenoid, 5/2 or 3/2-way convertible, 5/3-way pressurised, 5/3-way exhausted, 5/3-way closed	5/2 or 3/2-way single solenoid	3/2-way closed, single solenoid, 5/2-way double solenoid, 5/2-way single solenoid	3/2-way, closed, monostable, semi-automatic, 3/2-way, closed, monostable
<b>Operating pressure</b>	1.5 ... 10 bar	2 ... 10 bar	0 ... 8 bar	0 ... 12 bar
<b>Ambient temperature</b>	-20 ... 60 °C	-5 ... 40 °C	-25 ... 60 °C	-50 ... 60 °C
<b>Pneumatic connection 1</b>	G1/4, NPT1/4-18, QS-1/4, QS-10, QS-3/8, QS-5/16, QS-6, QS-8	G1/4		G1/4
<b>Standard nominal flow rate</b>	800 ... 1350 l/min	900 l/min	766 ... 2686 l/min	52 ... 1900 l/min
<b>Explosion prevention and protection</b>	II 2G, II 2D, For zone 1, 2, 21, 22, Ex t IIIIC T80 °C Db, Ex ia IIC T6 Ga, EPL Db (IEC-EX), EPL Ga (IEC-EX)	II 2G, II 2D, EPL Db (RU), EPL Dc (RU), c T6, EPL Gb (RU), EPL Gc (RU), c 40 °C	For zone 1, 2, 21, 22	For zone 1, 2, 21, 22
<b>New</b>	<ul style="list-style-type: none"> <li>• Additional versions</li> </ul>			<ul style="list-style-type: none"> <li>• Additional versions</li> </ul>
<b>Quick ordering of selected basic designs</b>	★			
<b>Description</b>	<ul style="list-style-type: none"> <li>• NAMUR interface</li> <li>• Rotatable seal for 3/2- or 5/2-way valve</li> <li>• Wide choice of EX solenoid systems</li> <li>• Sturdy and powerful</li> <li>• Extended temperature range</li> <li>• Outstanding value for money</li> </ul>	<ul style="list-style-type: none"> <li>• NAMUR interface</li> <li>• Variants for use in Ex zone I</li> </ul>	<ul style="list-style-type: none"> <li>• Suitable for process automation, for applications in the chemical and petrochemical industries</li> <li>• Suitable for outdoor use under harsh, dusty ambient conditions</li> <li>• Especially suitable for quarter turn actuators thanks to NAMUR flange pattern</li> <li>• Valve can switch between internal and external pilot air</li> <li>• Variants with TÜV approval up to SIL3 to IEC 61508</li> </ul>	<ul style="list-style-type: none"> <li>• Suitable for process automation, for applications in the chemical and petrochemical industries</li> <li>• Suitable for outdoor use under harsh, dusty ambient conditions</li> <li>• Especially suitable for quarter turn actuators thanks to NAMUR flange pattern</li> <li>• Variants with TÜV approval up to SIL4 to IEC 61508</li> </ul>
<b>online: →</b>	<a href="#">vsnc</a>	<a href="#">namur</a>	<a href="#">vofc</a>	<a href="#">vofd</a>



Sensor boxes

	 <b>Sensor boxes SRBG</b>	 <b>Sensor boxes SRBC</b>	 <b>Sensor boxes SRBE</b>
<b>Information on materials: housing</b>	PBT	Die cast aluminium	Die cast aluminium
<b>Operating voltage range AC</b>		0 ... 250 V	0 ... 250 V
<b>Operating voltage range DC</b>	6 ... 60 V	0 ... 175 V	0 ... 60 V
<b>Measuring principle</b>	Inductive	Inductive, magnetic reed, mechanical/electrical, for proximity sensor	Inductive, magnetic reed, mechanical/electrical, for proximity sensor
<b>Switching element function</b>	N/C contact, N/C contact or N/O contact, switchable, N/O contact	N/C contact, N/O contact, toggle switch, single-pole	N/C contact, N/O contact, toggle switch, single-pole, toggle switch, double-pole
<b>New</b>	• Additional versions	• New series	• New series
<b>Quick ordering of selected basic designs</b>		★	
<b>Description</b>	<ul style="list-style-type: none"> <li>• Compact housing with M12 plug connection</li> <li>• Direct mounting on quarter turn actuators to VDI/VDE 3845</li> <li>• AS-Interface® version with extended addressing options</li> <li>• Intrinsically safe version to ATEX and SIL 2 to IEC 61508</li> </ul>	<ul style="list-style-type: none"> <li>• Pre-assembled mounting adapter for ease of installation</li> <li>• Trip cams can be set easily without additional tools</li> <li>• Sturdy, corrosion-resistant design, ideal for use in harsh operating conditions</li> <li>• Clearly visible 3D position indicator allows rapid detection of the current position of the quarter turn actuator</li> </ul>	<ul style="list-style-type: none"> <li>• Trip cams can be set easily without additional tools</li> <li>• Sturdy, corrosion-resistant design, ideal for use in harsh operating conditions</li> <li>• Clearly visible 3D position indicator allows rapid detection of the current position of the quarter turn actuator</li> </ul>
<b>online: →</b>	<a href="#">srbg</a>	<a href="#">srbc</a>	<a href="#">srbe</a>



Sensor boxes

	 <b>Limit switch attachments SRAP</b>	 <b>Limit switch attachments DAPZ</b>
<b>Information on materials: housing</b>	Wrought aluminium alloy	
<b>Operating voltage range AC</b>		4 ... 250 V
<b>Operating voltage range DC</b>	15 ... 30 V	4 ... 250 V
<b>Measuring principle</b>	Magnetic Hall	Inductive, mechanical/electrical
<b>Switching element function</b>		N/C contact, N/O contact, changeover switch
<b>Description</b>	<ul style="list-style-type: none"> <li>• Based on standard VDI/VDE 3845 (NAMUR)</li> <li>• Analogue</li> <li>• For monitoring the position of quarter turn actuators</li> <li>• Sensors based on 2D Hall technology</li> </ul>	<ul style="list-style-type: none"> <li>• Square or round design</li> <li>• Drive interface to standard VDI/VDE 3845 (NAMUR)</li> <li>• With pneumatic, electric or inductive sensing</li> </ul>
<b>online: →</b>	<a href="#">srp</a>	<a href="#">dapz</a>



## Positioners

	 <p><b>Positioners CMSX</b></p>	<b>New</b>
<b>Standard nominal flow rate</b>	50 ... 130 l/min	
<b>Ambient temperature</b>	-5 ... 60 °C	
<b>Setpoint value</b>	0–10, 0–20 mA, 4–20 mA	
<b>Operating pressure</b>	3 ... 8 bar	
<b>Safety note</b>	Adjustable, holding, opening, closing	
<b>Operating voltage range DC</b>	21.6 ... 26.4 V	
<b>New</b>	<ul style="list-style-type: none"> <li>• Additional versions</li> </ul>	
<b>Quick ordering of selected basic designs</b>	★	
<b>Description</b>	<ul style="list-style-type: none"> <li>• For controlling the position of double-acting pneumatic quarter turn actuators in process automation systems</li> <li>• Simple and efficient position control based on the PID control algorithm</li> <li>• Suitable for quarter turn actuators with a swivel angle of approx. 90° and a mechanical interface to VDI/VDE Directive 3845</li> <li>• Power supply 24 V DC</li> </ul>	
<b>online: →</b>	<a href="#">cmsx</a>	



## Linear actuators

	 <p><b>Linear actuators Copac DLP</b></p>	 <p><b>Linear actuators with displacement encoder DFPI</b></p>	 <p><b>Linear actuators with displacement encoder DFPI-NB3P</b></p>	<b>New</b>
<b>Piston diameter</b>	80 mm, 100 mm, 125 mm, 160 mm, 200 mm, 250 mm, 320 mm	100 mm, 125 mm, 160 mm, 200 mm, 250 mm, 320 mm	100 mm, 125 mm, 160 mm, 200 mm, 250 mm, 320 mm	
<b>Stroke</b>	40 ... 600 mm	40 ... 990 mm	40 ... 990 mm	
<b>Theoretical force at 6 bar, advancing</b>	3016 ... 48255 N	4712 ... 48255 N	4712 ... 48255 N	
<b>Position sensing</b>	Via proximity sensor	With integrated displacement encoder	With integrated displacement encoder	
<b>New</b>			<ul style="list-style-type: none"> <li>• Additional versions to ISO 15552</li> </ul>	
<b>Description</b>	<ul style="list-style-type: none"> <li>• NAMUR port pattern for solenoid valves to VDI/VDE 3845</li> <li>• Integrated air supply</li> <li>• Connection for process valves to DIN 3358</li> </ul>	<ul style="list-style-type: none"> <li>• Closed-loop controlled actuator for all linear process valves</li> <li>• Optionally with integrated positioner and valve block</li> <li>• Position feedback via analogue 4 ... 20 mA signal for simple diagnostics</li> <li>• Easy integration into existing control architecture</li> <li>• Sturdy and compact housing for use outdoors</li> <li>• Connection for process valves to DIN 3358</li> </ul>	<ul style="list-style-type: none"> <li>• Standards-based linear actuators to ISO 15552</li> <li>• Easy connection to external positioners</li> <li>• Ideal for use in harsh ambient conditions</li> <li>• IP65, IP67, IP69K, NEMA4</li> <li>• ATEX 2GD certification</li> </ul>	
<b>online: →</b>	<a href="#">dtp</a>	<a href="#">dfpi</a>	<a href="#">dfpi</a>	



Quarter turn actuators

	 <p><b>Quarter turn actuators DFPD</b></p>	 <p><b>Quarter turn actuators DAPS</b></p>
<b>Design</b>	Rack and pinion	Scotch yoke system
<b>Mode of operation</b>	Double-acting, single-acting	Double-acting, single-acting
<b>Size of valve actuator</b>	10, 20, 40, 80, 120, 160, 240, 300, 480	0008, 0015, 0030, 0053, 0060, 0090, 0106, 0120, 0180, 0240, 0360, 0480, 0720, 0960, 1440, 1920, 2880, 3840, 4000, 5760, 8000
<b>Flange hole pattern</b>	F03, F04, F05, F0507, F0710, F1012	F03, F04, F05, F07, F10, F12, F14, F16, F25
<b>Operating pressure</b>	2 ... 8 bar	1 ... 8.4 bar
<b>Ambient temperature</b>	-50 ... 150 °C	-50 ... 150 °C
<b>New</b>	<ul style="list-style-type: none"> <li>• New series</li> </ul>	
<b>Quick ordering of selected basic designs</b>	★	
<b>Description</b>	<ul style="list-style-type: none"> <li>• NAMUR port pattern for solenoid valves to VDI/VDE 3845</li> <li>• Flange hole pattern to ISO 5211</li> <li>• Uniform torque characteristic across the entire rotation angle range of 90°</li> <li>• Mounting hole pattern to VDI/VDE 3845</li> <li>• Increased corrosion protection</li> </ul>	<ul style="list-style-type: none"> <li>• High break-away torques</li> <li>• Approved in accordance with Directive 2014/34/EU (ATEX)</li> <li>• Flange hole pattern to ISO 5211</li> <li>• Mounting hole pattern to VDI/VDE 3845</li> <li>• Available with handwheel as a manual emergency override</li> <li>• Corrosion-resistant variant made from stainless steel</li> </ul>
<b>online: →</b>	<a href="#">dfpd</a>	<a href="#">daps</a>

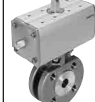
Ball valves and ball valve units

	 <p><b>Ball valves VAPB</b></p>	 <p><b>Ball valves VZBC</b></p>	 <p><b>Ball valve actuator units VZBC</b></p>
<b>Design</b>	2-way ball valve	2-way ball valve	2-way ball valve, quarter turn actuator
<b>Type of actuation</b>	Mechanical	Mechanical	Pneumatic
<b>Nominal width DN</b>	15 mm, 20 mm, 25 mm, 32 mm, 40 mm, 50 mm, 63 mm	15 mm, 20 mm, 25 mm, 32 mm, 40 mm, 50 mm, 65 mm, 80 mm, 100 mm	15 mm, 20 mm, 25 mm, 32 mm, 40 mm, 50 mm, 65 mm, 80 mm, 100 mm
<b>Process valve connection</b>	Rp1, Rp1 1/2, Rp1 1/4, Rp1/2, Rp1/4, Rp2, Rp2 1/2, Rp3/4, Rp3/8	Ring housing with threaded flange	Ring housing with threaded flange
<b>Flow rate Kv</b>	5.9 ... 535 m³/h	19.4 ... 1414 m³/h	19.4 ... 1414 m³/h
<b>Temperature of medium</b>	-20 ... 150 °C	-10 ... 200 °C	-10 ... 200 °C
<b>Description</b>	<ul style="list-style-type: none"> <li>• Automatable 2-way ball valve</li> <li>• Brass design</li> <li>• Blow-out proof shaft</li> <li>• Manual operation possible using hand lever</li> <li>• Connecting thread to DIN 2999 or DIN ISO 228-1</li> <li>• Mounting flange to ISO 5211</li> </ul>	<ul style="list-style-type: none"> <li>• Automatable 2-way ball valve with compact flange</li> <li>• Stainless steel design</li> <li>• Short installed length</li> <li>• Blow-out proof shaft</li> <li>• Manual operation possible using hand lever</li> <li>• Connecting thread to DIN 2999 or DIN ISO 228-1</li> <li>• Mounting flange to ISO 5211</li> <li>• ATEX certification for zone 1, 21, 2, 22</li> </ul>	<ul style="list-style-type: none"> <li>• Ball valve actuator unit with double- or single-acting quarter turn actuator</li> <li>• Stainless steel ball valve in compact design</li> <li>• NAMUR port pattern for solenoid valves/sensor boxes to VDI/VDE 3845</li> <li>• Flow is fully opened or closed in both directions</li> <li>• ATEX certification for zone 1, 21, 2, 22</li> </ul>
<b>online: →</b>	<a href="#">vapb</a>	<a href="#">vzbc</a>	<a href="#">vzbc</a>



Ball valves and ball valve units

	 <b>Ball valves</b> <b>VZBA</b>	 <b>Ball valve actuator units</b> <b>VZBA</b>	 <b>Ball valve actuator units</b> <b>VZPR</b>
<b>Design</b>	2-way ball valve, 3-way ball valve, L-shaped hole, T-shaped hole	2-way ball valve, 3-way ball valve, L-shaped hole, quarter turn actuator, T-shaped hole	2-way ball valve, quarter turn actuator
<b>Type of actuation</b>	Mechanical	Pneumatic	Electric, pneumatic
<b>Nominal width DN</b>	8 mm, 10 mm, 15 mm, 20 mm, 25 mm, 32 mm, 40 mm, 50 mm, 65 mm, 80 mm, 100 mm	8 mm, 10 mm, 15 mm, 20 mm, 25 mm, 32 mm, 40 mm, 50 mm, 65 mm, 80 mm, 100 mm	15 mm, 20 mm, 25 mm, 32 mm, 40 mm, 50 mm, 63 mm
<b>Process valve connection</b>	Rp1, Rp1 1/2, Rp1 1/4, Rp1/2, Rp1/4, Rp2, Rp2 1/2, Rp3, Rp3/4, Rp3/8, Rp4, Weld-on ends/weld-on ends	Rp1, Rp1 1/2, Rp1 1/4, Rp1/2, Rp1/4, Rp2, Rp2 1/2, Rp3, Rp3/4, Rp3/8, Rp4, Weld-on ends/weld-on ends	Rp1, Rp1 1/2, Rp1 1/4, Rp1/2, Rp1/4, Rp2, Rp2 1/2, Rp3/4, Rp3/8
<b>Flow rate Kv</b>	7 ... 1414 m <sup>3</sup> /h	7 ... 1414 m <sup>3</sup> /h	
<b>Temperature of medium</b>	-10 ... 200 °C	-10 ... 200 °C	-20 ... 150 °C
<b>Description</b>	<ul style="list-style-type: none"> <li>• Automatable 2-way or 3-way ball valve</li> <li>• Stainless steel design</li> <li>• Blow-out proof shaft</li> <li>• Manual operation possible using hand lever</li> <li>• Connecting thread to DIN 2999 or DIN ISO 228-1</li> <li>• Mounting flange to ISO 5211</li> <li>• ATEX certification for zone 1, 21, 2, 22</li> </ul>	<ul style="list-style-type: none"> <li>• Ball valve actuator unit with double- or single-acting quarter turn actuator</li> <li>• Stainless steel ball valve</li> <li>• NAMUR port pattern for solenoid valves/sensor boxes to VDI/VDE 3845</li> <li>• Flow is fully opened or closed in both directions</li> <li>• ATEX certification for zone 1, 21, 2, 22</li> </ul>	<ul style="list-style-type: none"> <li>• Ball valve actuator unit with double-acting quarter turn actuator</li> <li>• Brass ball valve</li> <li>• NAMUR port pattern for solenoid valves/sensor boxes to VDI/VDE 3845</li> <li>• Flow is fully opened or closed in both directions</li> </ul>
<b>online:</b> →	<a href="#">vzba</a>	<a href="#">vzba</a>	<a href="#">vzpr</a>



Angle seat valves

	 <b>Angle seat valves</b> <b>VZXF</b>
<b>Design</b>	Poppet valve with spring return
<b>Type of actuation</b>	Pneumatic
<b>Nominal width DN</b>	15 mm, 20 mm, 25 mm, 32 mm, 40 mm, 50 mm
<b>Nominal width</b>	12 ... 45 mm
<b>Process valve connection</b>	G1, G1 1/2, G1 1/4, G1/2, G2, G3/4, NPT1, NPT1 1/2, NPT1 1/4, NPT1/2, NPT2, NPT3/4
<b>Flow rate Kv</b>	3.3 ... 43 m <sup>3</sup> /h
<b>Operating pressure</b>	-0.9 ... 40 bar
<b>Temperature of medium</b>	-40 ... 200 °C
<b>Quick ordering of selected basic designs</b>	★
<b>Description</b>	<ul style="list-style-type: none"> <li>• Sturdy design</li> <li>• Stainless steel and gunmetal process valves with stainless steel, brass or aluminium actuators</li> <li>• For operating pressures up to 40 bar</li> <li>• Safety position “closing”</li> <li>• Different actuator sizes and housing materials</li> <li>• Selection of different seat and shaft seals</li> <li>• Flow direction is freely selectable</li> <li>• For liquids, gases and other easily contaminated media</li> <li>• Easy-to-clean design</li> </ul>
<b>online:</b> →	<a href="#">vzxf</a>



Solenoid-actuated media valves

	 <b>Solenoid valves VZWD</b>	 <b>Solenoid valves VZWM</b>	 <b>Solenoid valves MN1H</b>
<b>Design</b>	Directly actuated poppet valve	Poppet valve with diaphragm seal	Diaphragm valve
<b>Type of actuation</b>	Electric	Electric	Electric
<b>Nominal width</b>	1 ... 6 mm	13 ... 50 mm	13 ... 40 mm
<b>Process valve connection</b>	G1/4, G1/8, NPT1/4, NPT1/8	G1, G1 1/2, G1 1/4, G1/2, G1/4, G2, G3/4, G3/8	G1, G1 1/2, G1/2, G1/4, G3/4, G3/8
<b>Flow rate Kv</b>	0.06 ... 430 l/min	1.6 ... 31000 l/min	2000 ... 30500 l/min
<b>Operating pressure</b>	0 ... 90 bar	0.5 ... 10 bar	0.5 ... 10 bar
<b>Temperature of medium</b>	-10 ... 80 °C	-10 ... 60 °C	-10 ... 60 °C
<b>Quick ordering of selected basic designs</b>	★	★	
<b>Description</b>	<ul style="list-style-type: none"> <li>• Extensive pressure range</li> <li>• Directly actuated poppet valve</li> <li>• No pressure difference required</li> <li>• Can also be used in vacuum technology</li> </ul>	<ul style="list-style-type: none"> <li>• Poppet valve with diaphragm seal</li> <li>• Brass or stainless steel casting design</li> <li>• Electrical connection via solenoid armature tube</li> <li>• Wide range of coils</li> <li>• Coil can be ordered separately</li> </ul>	<ul style="list-style-type: none"> <li>• Piloted diaphragm valve</li> <li>• Brass design</li> <li>• Can only be used for gaseous media</li> <li>• Adjustable closing cushioning, in-line mounting or through-hole</li> </ul>
<b>online: →</b>	<a href="#">vzwd</a>	<a href="#">vzwm</a>	<a href="#">mn1h-2</a>

Solenoid-actuated media valves

	 <b>Solenoid valves VZWP</b>	 <b>Solenoid valves VZWF</b>	 <b>Reverse jet pulse valves VZWE-E, VZWE-F</b>
<b>Design</b>	Piloted piston poppet valve	Diaphragm valve, force pilot operated	Angled version, straight version with flange, diaphragm valve
<b>Type of actuation</b>	Electric	Electric	Electric
<b>Nominal width</b>	13 ... 25 mm	13.5 ... 50 mm	20 ... 76 mm
<b>Process valve connection</b>	G1, G1/2, G1/4, G3/4, G3/8, NPT1, NPT1/2, NPT1/4, NPT3/4, NPT3/8	G1, G1 1/2, G1 1/4, G1/2, G1/4, G2, G3/4, G3/8, NPT1, NPT1 1/2, NPT1 1/4, NPT1/2, NPT1/4, NPT2, NPT3/4, NPT3/8	Flange diameter 60, 75, 89, G1, G1 1/2, G2, G2 1/2, G3/4
<b>Flow rate Kv</b>	1.5 ... 12250 l/min	1.8 ... 29900 l/min	15 ... 210 m <sup>3</sup> /h
<b>Operating pressure</b>	0.5 ... 40 bar	0 ... 10 bar	0.35 ... 8 bar
<b>Temperature of medium</b>	-10 ... 80 °C	-10 ... 80 °C	-20 ... 60 °C
<b>Quick ordering of selected basic designs</b>		★	
<b>Description</b>	<ul style="list-style-type: none"> <li>• For all applications with a differential pressure of min. 0.5 bar</li> <li>• For high pressures and high flow rates with relatively small solenoids</li> <li>• For controlling gaseous and liquid media in open circuits</li> </ul>	<ul style="list-style-type: none"> <li>• High flow rates</li> <li>• Large nominal diameters with relatively small solenoids</li> <li>• No pressure difference required</li> <li>• Can also be used in vacuum technology</li> </ul>	<ul style="list-style-type: none"> <li>• High flow rates</li> <li>• For mechanically cleaning filters and dust filter systems</li> <li>• Fast opening and closing times</li> <li>• Sturdy pilot system</li> </ul>
<b>online: →</b>	<a href="#">vzwp</a>	<a href="#">vzwf</a>	<a href="#">vzwe</a>

Pneumatically actuated media valves

	 <b>Pinch valves</b> <b>VZQA</b>	 <b>Pneumatic valves</b> <b>VLX</b>
<b>Design</b>	Pneumatically actuated pinch valve	Diaphragm valve
<b>Valve function</b>	2/2-way closed, monostable, 2/2-way open, monostable	2/2-way, closed, monostable
<b>Type of control</b>	Pneumatic	Pneumatic
<b>Nominal width DN</b>	6 mm, 15 mm, 25 mm	
<b>Nominal width</b>		13 ... 25 mm
<b>Process valve connection</b>	G1, G1/2, G1/4, NPT1/2, NPT1/4, Clamp to ASME-BPE type A, clamp to ASME-BPE type B, clamp to DIN 32676 series A	G1, G1/2, G1/4, G3/4, G3/8
<b>Flow rate Kv</b>	0.7 ... 18 m <sup>3</sup> /h	2400 ... 14000 l/min
<b>Operating pressure</b>	0 ... 6 bar	1 ... 10 bar
<b>Temperature of medium</b>	-5 ... 100 °C	-10 ... 80 °C
<b>New</b>	<ul style="list-style-type: none"> <li>• Additional connection size</li> <li>• Modular, interchangeable component parts</li> </ul>	
<b>Description</b>	<ul style="list-style-type: none"> <li>• Modular design</li> <li>• Quick and easy replacement of the diaphragm</li> <li>• Selection of different materials for housing and connector caps</li> <li>• Different connection cap designs (G and NPT thread, clamp ferrule to DIN 32676 and ASME-BPE)</li> <li>• For critical, abrasive and viscous media</li> <li>• Up to 2 million switching cycles</li> <li>• FDA-compliant materials</li> <li>• Easy-to-clean design</li> <li>• Flow direction is freely selectable</li> </ul>	<ul style="list-style-type: none"> <li>• Poppet valve</li> <li>• Indirectly actuated</li> <li>• Brass design</li> <li>• In-line mounting or via through-holes</li> </ul>
<b>online:</b> →	<a href="#">vzqa</a>	<a href="#">vlx</a>

Air preparation





- Service unit combinations and individual units for compressed air preparation in two series: MS and D (in metal or polymer)
- [www.festo.com/pa/airprep](http://www.festo.com/pa/airprep)

17 Pneumatic connection technology





- Piping
  - Tubing
  - Plug connectors
  - Couplings
  - Distributors
  - Protective tubing systems
  - Accessories
- [www.festo.com/pa/fittings](http://www.festo.com/pa/fittings)

Control cabinets





	 <p><b>Factory automation</b></p>	 <p><b>Process automation</b></p>	 <p><b>Control cabinets for control systems</b></p>
<p><b>Technical data</b></p>	<ul style="list-style-type: none"> <li>• Simple to complex control cabinet designs</li> <li>• Application-specific combination of components</li> <li>• Fully tested, with test certificate</li> <li>• Ready-to-install</li> <li>• Complete documentation</li> <li>• Design conforms to:                             <ul style="list-style-type: none"> <li>– EN 60204-1</li> <li>– ATEX zone 1 and 21 (pneumatic only), ATEX zone 2 and 22 (electric and electropneumatic)</li> <li>– UL-508 A</li> </ul> </li> <li>• Implementation of safety functions</li> <li>• Different bus technologies</li> </ul>	<ul style="list-style-type: none"> <li>• Simple to complex control cabinet designs</li> <li>• Application-specific combination of components</li> <li>• Different operating voltages</li> <li>• Fully tested, with test certificate</li> <li>• Ready-to-install</li> <li>• Complete documentation</li> <li>• Design conforms to:                             <ul style="list-style-type: none"> <li>– EN 60204-1</li> <li>– ATEX zone 1 and 21 (pneumatic only), ATEX zone 2 and 22 (electric and electropneumatic)</li> <li>– UL-508 A</li> </ul> </li> <li>• Implementation of safety functions</li> <li>• Wide range of bus technologies</li> <li>• Compliance with special cleanliness and hygiene requirements</li> <li>• Special materials</li> <li>• Protected against the ingress of liquids and foreign matter</li> <li>• Heating or cooling elements</li> <li>• Intrinsically safe valve terminal technology</li> <li>• Hot swap inspection window</li> </ul>	<ul style="list-style-type: none"> <li>• Simple to complex control cabinet designs</li> <li>• 1 ... 31 axes</li> <li>• Application-specific combination of components</li> <li>• Use of the latest innovations and technologies</li> <li>• Fully tested, with test certificate</li> <li>• Ready-to-install</li> <li>• Complete documentation</li> <li>• Design conforms to:                             <ul style="list-style-type: none"> <li>– EN 60204-1</li> <li>– ATEX zone 1 and 21 (pneumatic only), ATEX zone 2 and 22 (electric and electropneumatic)</li> <li>– UL-508 A</li> </ul> </li> <li>• Implementation of safety functions</li> <li>• Wide range of bus technologies</li> </ul>
<p><b>Description</b></p>	<ul style="list-style-type: none"> <li>• Control cabinets made to measure</li> <li>• Pneumatic, electric, combined</li> <li>• Individually configured</li> <li>• Adapted to requirements in industrial automation</li> <li>• Design and sizing included</li> </ul>	<ul style="list-style-type: none"> <li>• Control cabinets made to measure</li> <li>• Pneumatic, electric, combined</li> <li>• Individually configured</li> <li>• Adapted to requirements in process automation</li> <li>• Design and sizing included</li> </ul>	<ul style="list-style-type: none"> <li>• Made-to-measure control cabinets for handling systems</li> <li>• Software package for third-party devices included</li> <li>• Individually configurable</li> <li>• Adapted to requirements for handling solutions → “Cartesian systems” on page 67</li> </ul>
<p><b>online:</b> →</p>	<p><a href="#">ready-to-install</a></p>	<p><a href="#">ready-to-install</a></p>	<p><a href="#">ready-to-install</a></p>

## Mounting plates and assemblies

	 <b>Mounting plates</b>	 <b>Assemblies</b>
<b>Technical data</b>	<ul style="list-style-type: none"> <li>• Customised support plate shape</li> <li>• Support plate available in different materials</li> <li>• Application-specific combination of components</li> <li>• Fully assembled, connected and wired</li> <li>• Defined interfaces</li> <li>• Ready-to-install</li> <li>• Fully tested, with test certificate</li> <li>• Complete documentation</li> <li>• Design conforms to:                             <ul style="list-style-type: none"> <li>– EN 60204-1</li> <li>– ATEX zone 1 and 21 (pneumatic only), ATEX zone 2 and 22 (electric and electropneumatic)</li> <li>– UL-508 A</li> </ul> </li> <li>• Implementation of safety functions</li> </ul>	<ul style="list-style-type: none"> <li>• Combination of various pneumatic and/or electric components to create a single unit</li> <li>• Application-specific combination of components</li> <li>• Accessories mounted on sub-assembly</li> <li>• Use of the latest innovations and technologies</li> <li>• Ready-to-install</li> <li>• Fully tested, with test certificate</li> <li>• Complete documentation</li> <li>• Design conforms to:                             <ul style="list-style-type: none"> <li>– EN 60204-1</li> <li>– ATEX zone 1 and 21 (pneumatic only), ATEX zone 2 and 22 (electric and electropneumatic)</li> <li>– UL-508 A</li> </ul> </li> <li>• Implementation of safety functions</li> </ul>
<b>Description</b>	<ul style="list-style-type: none"> <li>• Machine-specific pre-assembly of pneumatic and electric components on support plate</li> <li>• Tubing and wiring included</li> <li>• Defined interfaces for simple installation directly in the system</li> </ul>	<ul style="list-style-type: none"> <li>• Pneumatic and electric components pre-assembled to create a function unit</li> <li>• Can be combined from around 30000 catalogue components</li> <li>• Connections included</li> <li>• For integration in machines</li> </ul>
<b>online:</b> →	<a href="#">ready-to-install</a>	<a href="#">ready-to-install</a>



Integration solutions

	 <b>Manifold duct plates</b>	 <b>Cartridge solutions</b>	 <b>Sheet-metal constructions and special housings</b>	 <b>Function blocks</b>
<b>Technical data</b>	<ul style="list-style-type: none"> <li>• Freely selectable manifold duct plate shape</li> <li>• Combination of over 30000 catalogue components</li> <li>• High density of components</li> <li>• No tubing</li> <li>• Variable positioning of mechanical, pneumatic and electrical interfaces</li> <li>• Integration of customised components</li> <li>• Available with protective cover</li> <li>• Fully tested</li> <li>• Ready-to-install</li> <li>• Complete documentation</li> <li>• Implementation of safety functions</li> </ul>	<ul style="list-style-type: none"> <li>• Space-saving thanks to extremely compact design</li> <li>• Pneumatic functions integrated in a single compact housing</li> <li>• Housing in different materials</li> <li>• No tubing required</li> <li>• Minimal cabling required</li> <li>• Significant design freedom</li> <li>• Variable integration options on and within the machine</li> <li>• Sturdy design</li> <li>• Fully tested</li> <li>• Ready-to-install</li> <li>• Complete documentation</li> </ul>	<ul style="list-style-type: none"> <li>• Sheet-metal structures                             <ul style="list-style-type: none"> <li>– Customised shape and size</li> <li>– Reduced weight and number of assembly parts</li> </ul> </li> <li>• Special housing                             <ul style="list-style-type: none"> <li>– Customised shape</li> <li>– Customised dimensions</li> <li>– Various materials</li> <li>– Compact, space-optimised format</li> <li>– Protection against environmental influences and unauthorised access</li> </ul> </li> <li>• In combination                             <ul style="list-style-type: none"> <li>– Alternative to conventional control cabinets</li> <li>– Variable integration options on and within the machine</li> <li>– Short tubing and cable lengths</li> <li>– Attractive design</li> </ul> </li> </ul>	<ul style="list-style-type: none"> <li>• No tubing required thanks to drilled ducts</li> <li>• Housing available in different materials</li> <li>• Customised design of the pneumatic interfaces for the system</li> <li>• Ideal for a small number of components and variable connection options</li> <li>• Extremely economical, even for small quantities</li> </ul>
<b>Description</b>	<ul style="list-style-type: none"> <li>• Ideal for a large number of pneumatic connections in an extremely compact space</li> <li>• No tubing</li> <li>• Compact</li> <li>• Easy to service</li> <li>• Immune to malfunction</li> </ul>	<ul style="list-style-type: none"> <li>• Integration of various pneumatic functions in one component</li> <li>• No need for single housings</li> <li>• Ideal for applications that require a highly compact design</li> </ul>	<ul style="list-style-type: none"> <li>• Reduced weight thanks to optimal use of materials with sheet-metal constructions</li> <li>• Protection against environmental influences and unauthorised access</li> <li>• Ideally combined as a control cabinet directly in the system</li> </ul>	<ul style="list-style-type: none"> <li>• Compressed air supply for pneumatic components via drilled ducts</li> <li>• Ideal for a small number of pneumatic components and variable connection options</li> <li>• Compact and easy to service</li> </ul>
<b>online:</b> →	<a href="#">ready-to-install</a>	<a href="#">ready-to-install</a>	<a href="#">ready-to-install</a>	<a href="#">ready-to-install</a>

## Integration solutions

<b>Type</b>	 <b>Profile solutions</b>
<b>Technical data</b>	<ul style="list-style-type: none"> <li>• Profiles in customised cross sections and lengths</li> <li>• Integrated ducts for straight-line routing of the compressed air</li> <li>• Common air supply for multiple valves or valve terminals via a single duct</li> <li>• Combination of exhaust air and supply air without tubing, even over long distances</li> <li>• Supply of compressed air at different locations</li> <li>• No tubing required</li> <li>• Significantly reduced cabling</li> <li>• Modular, easy to realise construction</li> <li>• Optional: profile as mechanical mounting element for other components or as a supporting part of the machine frame</li> </ul>
<b>Description</b>	<ul style="list-style-type: none"> <li>• Extruded profiles in combination with valves as a valve terminal</li> <li>• For the distribution of compressed air in the machine concept</li> <li>• Customised profile cross sections available</li> </ul>
<b>online:</b> →	<a href="#">ready-to-install</a>

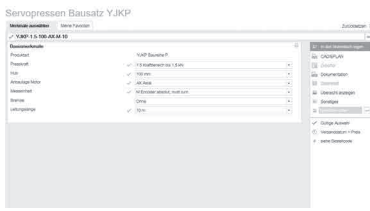

Software tool

<b>Configurator</b>		<p>Design a product with numerous features reliably and quickly with the help of the configurator.</p> <p>Select all the required product features step-by-step. The use of logic checks ensures that only correct configurations are available for selection.</p> <p>The configurator is part of the electronic catalogue and is not available as a separate software program.</p>
---------------------	---	---



Function-specific systems

		<b>New</b>
	<b>Servo press kits YJKP</b>	
<b>Working stroke</b>	100 ... 400 mm	
<b>Press force</b>	0 ... 17 kN	
<b>Feed speed</b>	0 ... 250 mm/s	
<b>Accuracy in ± % FS</b>	0.5 %FS	
<b>Protocol</b>	Modbus® TCP, EtherNet/IP, TCP/IP	
<b>New</b>	<ul style="list-style-type: none"> <li>• New series</li> </ul>	
<b>description</b>	<ul style="list-style-type: none"> <li>• Modular system kit comprising operating software GSAY, electric cylinder with spindle drive ESBF, motor EMMS-AS, motor controller CMMP-AS, force sensor and controller CECC-X together with the required accessories</li> <li>• Less expensive than conventional press-fitting systems</li> <li>• Pre-installed operating software GSAY offers precisely the required application-specific functions</li> <li>• Commissioning made easy: parameterisation instead of programming</li> <li>• For top quality: real-time monitoring of the press-fitting operation and clear visualisation of the force/displacement curves</li> <li>• Fit for Industry 4.0 thanks to the OPC UA interface at the controller</li> </ul>	
<b>online:</b> →	<a href="#">yjkp</a>	





## After sales and technical support services



Type	 Commissioning	 Maintenance
<b>Services</b>	<ul style="list-style-type: none"> <li>• Mechanical, pneumatic and electrical integration and configuration of Festo automation solutions</li> <li>• Configuration and parameterisation</li> <li>• Optimisation with test run</li> <li>• Data backup and documentation</li> <li>• Technical guidance and briefing of machine operators</li> </ul>	<p>Implementation of the following preventive maintenance measures to DIN 31051:</p> <ul style="list-style-type: none"> <li>• Inspections                             <ul style="list-style-type: none"> <li>– Checking for damage and wear characteristics</li> <li>– Checking mechanical, pneumatic and electrical connections and connectors</li> <li>– Checking lubrication</li> <li>– Checking compressed air preparation</li> <li>– Carrying out component-specific inspections</li> </ul> </li> <li>• Maintenance                             <ul style="list-style-type: none"> <li>– Lubrication/relubrication of guides</li> <li>– Tightening connectors</li> <li>– Replacement of air filters</li> <li>– Replacement of silencers</li> <li>– Carrying out component-specific preventive maintenance tasks</li> </ul> </li> <li>• Repair                             <ul style="list-style-type: none"> <li>– Troubleshooting</li> <li>– Solution finding</li> <li>– Error elimination</li> <li>– Elimination of leakages</li> <li>– Replacement or repair of components</li> </ul> </li> </ul>
<b>Description</b>	<ul style="list-style-type: none"> <li>• Support with professional commissioning of Festo automation solutions</li> <li>• Expert briefing of machine operators</li> </ul>	<ul style="list-style-type: none"> <li>• Preventive and corrective maintenance</li> <li>• Directly on your system</li> <li>• For high machine availability and rapid assistance should the worst happen</li> </ul>
<b>online:</b> →	<a href="http://www.festo.com/services">www.festo.com/services</a>	<a href="http://www.festo.com/services">www.festo.com/services</a>

## After sales and technical support services

Type	 Repair service	 Technical support
<b>Services</b>	<ul style="list-style-type: none"> <li>• Inspection</li> <li>• Analysis of economic efficiency</li> <li>• Repair or replacement of faulty components or wearing parts</li> <li>• Leakage testing</li> <li>• Functional testing</li> </ul>	<ul style="list-style-type: none"> <li>• Technical advice: answering technical questions or solving technical problems                             <ul style="list-style-type: none"> <li>– Online support</li> <li>– Hotline support</li> </ul> </li> <li>• Technical customer service: Technical support on site                             <ul style="list-style-type: none"> <li>– Remote support</li> <li>– On-site support</li> </ul> </li> </ul>
<b>Description</b>	<ul style="list-style-type: none"> <li>• Extended service life</li> <li>• Reduced costs</li> </ul>	<ul style="list-style-type: none"> <li>• Answering technical questions</li> <li>• Technical support on site</li> </ul>
<b>online:</b> →	<a href="http://www.festo.com/services">www.festo.com/services</a>	<a href="http://www.festo.com/services">www.festo.com/services</a>

Energy Saving Services

	 <span style="color: blue; font-weight: bold;">New</span> <b>PreAudit</b>	 <b>Energy analysis of compressed air generation</b>	 <b>Compressed air quality analysis</b>	 <span style="color: blue; font-weight: bold;">New</span> <b>Pressure drop measurement</b>
<b>Services</b>	<ul style="list-style-type: none"> <li>• Energy analysis – assessment</li> <li>• Compressed air quality analysis</li> <li>• Pressure drop measurement</li> <li>• Compressed air consumption analysis</li> <li>• Leakage detection – quick check</li> <li>• Machine analysis for energy efficiency – quick check</li> <li>• Comprehensive report on the analysis with weighted recommendations on what to do next</li> </ul>	<ul style="list-style-type: none"> <li>• Measurement of compressor operating times as well as load/idle times</li> <li>• Power consumption measurement</li> <li>• Flow measurement/consumption measurement</li> <li>• Pressure measurement (level and band width)</li> <li>• Estimate of leakage volume</li> <li>• Comparison of energy consumption and compressed air volume supplied</li> </ul>	<ul style="list-style-type: none"> <li>• Inspection of decentralised air preparation at point of usage</li> <li>• Measurement of residual oil content up to class 2 (ISO 8573-1:2010)</li> <li>• Measurement of pressure dew point up to class 2 (ISO 8573-1:2010)</li> <li>• Analysis of measurement results and recommendation of improvement measures (if applicable)</li> <li>• Documentation of all measurement results</li> <li>• 3 hours on-site service (max. 3 measurements; additional time on request)</li> </ul>	<ul style="list-style-type: none"> <li>• Measurement of the pressure in the compressor room (input), in production (draw off) and storage of the results</li> <li>• Recording of the pressure drop using multiple pressure sensors with data loggers</li> <li>• Evaluation and comparison of the pressure profiles</li> <li>• Controlled pressure reduction following evaluation</li> <li>• Demonstration of pressure fluctuations in production</li> </ul>
<span style="color: blue; font-weight: bold;">New</span>	<ul style="list-style-type: none"> <li>• New service</li> </ul>			<ul style="list-style-type: none"> <li>• New service</li> </ul>
<b>Description</b>	<ul style="list-style-type: none"> <li>• Implementation of the Festo Energy Saving Services to DIN ISO 11011</li> <li>• Analysis of your compressed air system by experts on site</li> <li>• Important advice and recommendations on the topic of energy efficiency – immediate identification of worthwhile measures</li> </ul>	<ul style="list-style-type: none"> <li>• Energy Saving Service to DIN ISO 11011</li> <li>• Determination of a clear consumption profile</li> <li>• Information about the output reserves of the compressed air system</li> <li>• Measurement during operation</li> </ul>	<ul style="list-style-type: none"> <li>• Energy Saving Service to DIN ISO 11011</li> <li>• Assurance of optimum compressed air quality</li> <li>• Increased service life of components</li> <li>• Minimisation of unexpected production downtimes</li> <li>• Class 1 on request</li> </ul>	<ul style="list-style-type: none"> <li>• Energy Saving Service to DIN ISO 11011</li> <li>• Recording of the pressure drop in the system</li> <li>• Energy savings of up to 8% by reducing the compressed air pressure</li> </ul>
<b>online:</b> →	<a href="http://www.festo.com/services">www.festo.com/services</a>	<a href="http://www.festo.com/services">www.festo.com/services</a>	<a href="http://www.festo.com/services">www.festo.com/services</a>	<a href="http://www.festo.com/services">www.festo.com/services</a>

	 <p><b>Compressed air consumption analysis</b></p>	 <p><b>Leakage detection and elimination</b></p>	 <p><b>Machine analysis for energy efficiency</b></p>
<p><b>Services</b></p>	<ul style="list-style-type: none"> <li>• Installation and removal of the measuring equipment with standard components (fittings, tubing, etc.)</li> <li>• Measurement of flow rate, consumption and pressure with machine running and when idle</li> <li>• Determination and analysis of different characteristics                             <ul style="list-style-type: none"> <li>– Consumption per machine cycle</li> <li>– Average consumption per minute</li> <li>– Average pressure</li> <li>– Max./min. pressure</li> <li>– Max./min. rate of air flow</li> </ul> </li> <li>• Documentation of measurement results including a graphic of the measurement results, optionally available as a PDF or colour printout</li> <li>• 3 hours on-site service (additional time on request)</li> </ul>	<ul style="list-style-type: none"> <li>• Detection of compressed air leakages using highly sensitive ultrasound detectors during operation</li> <li>• Checking of the complete compressed air system from the compressor to the pneumatic application</li> <li>• Classification of the leakages according to size and cost</li> <li>• Documentation of faulty components as well as of the type and cause of the fault</li> <li>• Leakage report containing:                             <ul style="list-style-type: none"> <li>– Recommended measures</li> <li>– Spare parts required</li> <li>– Estimated repair time</li> <li>– Prioritisation of measures</li> <li>– Assessment as to whether repair can be carried out while the machine is in operation</li> </ul> </li> <li>• Information on optimisation options</li> <li>• Documentation of measures carried out</li> <li>• Online access to all results and repair data via the Energy Saving Assessment Portal</li> </ul>	<p><b>New</b></p> <ul style="list-style-type: none"> <li>• Identification and analysis of the pneumatic applications of relevance to energy consumption</li> <li>• Measurement of flow rate, consumption and pressure of the relevant compressed air applications</li> <li>• Establish and recommend optimisation measures</li> <li>• Estimation of the costs and savings, including the predicted amortisation time</li> <li>• Installation and removal of the measuring equipment with standard components (fittings, tubing, etc.)</li> <li>• Measurement of flow rate, consumption and pressure with machine running and idle</li> <li>• Documentation of the measurement results including graphical representation</li> </ul>
<p><b>New</b></p>			<ul style="list-style-type: none"> <li>• New service</li> </ul>
<p><b>Description</b></p>	<ul style="list-style-type: none"> <li>• Energy Saving Service to DIN ISO 11011</li> <li>• Determination of exact compressed air consumption</li> <li>• Optimal configuration of compressed air supply</li> <li>• No pressure drop due to undersupply</li> <li>• No unnecessary energy costs due to oversupply</li> </ul>	<ul style="list-style-type: none"> <li>• Energy Saving Service to DIN ISO 11011</li> <li>• Detection and repair of leakages in production plants</li> <li>• Immediate energy and operating cost savings</li> </ul>	<ul style="list-style-type: none"> <li>• Energy Saving Service to DIN ISO 11011</li> <li>• Reviewing of systems with respect to possible energy optimisation potential</li> <li>• Documentation of the analysed compressed air applications</li> </ul>
<p><b>online:</b> →</p>	<p><a href="http://www.festo.com/services">www.festo.com/services</a></p>	<p><a href="http://www.festo.com/services">www.festo.com/services</a></p>	<p><a href="http://www.festo.com/services">www.festo.com/services</a></p>

**Argentina**

Festo S.A.  
Edison 2392  
1640 Buenos Aires  
P +54 0810-444-3127  
ventas@ar.festo.com

**Australia**

Festo Pty. Ltd.  
Browns Road 179-187  
3174 Melbourne  
P +61 397 9595-55  
F +61 397 9597-87  
info\_au@festo.com

**Austria**

Festo Gesellschaft m.b.H.  
Linzer Straße 227  
1140 Vienna  
P +43 (0)1 910 75-0  
F +43 (0)1 910 75-250  
automation@festo.at

**Belarus**

IUP Festo  
Masherov avenue 78  
220035 Minsk  
P +375 (0)17 204 85 58  
F +375 (0)17 204 85 59  
info\_by@festo.com

**Belgium**

Festo Belgium nv  
Kolonel Bourgstraat 101  
1030 Brussels  
P +32 (0)2 702 32 11  
F +32 (0)2 702 32 09  
info\_be@festo.com

**Brazil**

Festo Brasil Ltda  
Rua Guiseppe Crespi 76  
04183-080 São Paulo  
P +55 (11) 5013-1600  
F +55 (11) 5013-1801  
linhadireta@br.festo.com

**Bulgaria**

Festo EOOD  
Bul. Christophor Kolumb 9  
1592 Sofia  
P +359 (0)2 960 07 12  
F +359 (0)2 960 07 13  
festo\_bg@festo.com

**Canada**

Festo Inc.  
Explorer Drive 5300  
L4W 5G4 Mississauga  
P +1 (0) 905 614 4600  
F +1 (0) 877 393 3786  
info\_ca@festo.com

**Chile**

Festo S.A.  
Av. Américo Vespucio 760  
9020000 Santiago de Chile  
P +56 (2) 2690 2801  
F +56 (2) 2690 2860  
info.chile@cl.festo.com

**China**

Festo (China) Ltd.  
Yunqiao Road, 1156  
201206 Shanghai  
P +86 21 60 81 51 00  
F +86 21 58 54 03 00  
info\_cn@cn.festo.com

**Colombia**

Festo S.A.S.  
Autopista Medellín Km 6,3  
Tenjo, Cundinamarca  
P +57 (1) 865 7788  
F +57 (1) 865 7729  
mercadeo@co.festo.com

**Croatia**

Festo d.o.o.  
Nova Cesta 181  
10000 Zagreb  
P +385 1 619 1969  
F +385 1 619 1818  
info\_hr@festo.com

**Czech Republic**

Festo, s.r.o.  
Modřanská 543/76  
14700 Prague  
P +420 261 09 96 11  
F +420 241 77 33 84  
info\_cz@festo.com

**Denmark**

Festo A/S  
Islevalvej 180  
2610 Rødovre  
P +45 7021 1090  
F +45 7021 1099  
sales\_dk@festo.com

**Estonia**

Festo OY AB Eesti Filiaal  
A.H. Tammsaare tee 118B  
12918 Tallinn  
P +372 666 1560  
F +372 666 15 6  
info\_ee@festo.com

**Finland**

Festo Oy  
Mäkituvantie 9  
1511 Vantaa  
P +358 (09) 87 06 51  
F +358 (09) 87 06 52 00  
info\_fi@festo.com

**France**

Festo Eurl  
Rue du clos sainte Catherine 8  
94360 Bry-sur-Marne  
P +33 (0) 1 48 82 65 00  
F +33 (0) 1 48 82 65 01  
info\_fr@festo.com

**Germany**

Festo Vertrieb GmbH & Co. KG  
Festo Campus 1  
73734 Esslingen  
P +49 711 347-1111  
F +49 0711 347-2244  
info\_de@festo.com

**Greece**

Festo Ltd.  
Tatoiou Ave. 92  
P.C. 14452 Metamorfofi  
P +30 210 341 29 00  
F +30 210 341 29 05  
info\_gr@festo.com

**Hong Kong**

Festo Ltd  
Castle Peak Road 495  
Kowloon  
P +852 3904 20 91  
F +852 2745 91 43  
info\_hk@festo.com

**Hungary**

Festo Kft.  
Csillaghegyi út 32-34  
1037 Budapest  
P +36 1 436 51 11  
F +36 1 436 51 01  
info\_hu@festo.com

**India**

Festo India Private Limited  
Bommasandra Indl. Area 237B  
560 099 Bengaluru  
P +91 (0) 1800 425 0036  
F +91 (0) 1800 121 0036  
sales.in@festo.com

**Indonesia**

PT. Festo  
Jl. Tekno V Blok A/1 Sektor XI  
15314 Tangerang  
P +62 21 27507900  
F +62 21 27507998  
info\_id@festo.com

**Iran**

Festo Pneumatic S.K.  
Special Karaj Road  
1389793761 Teheran  
P +98 (0)21 44 52 24 09  
F +98 (0)21 44 52 24 08  
Mailroom@festo.ir

**Ireland**

Festo Limited  
Unit 5 Sandyford Park  
Dublin  
P +353 (0)1 295 49 55  
F +353 (0)1 295 56 80  
sales\_ie@festo.com

**Israel**

Festo Pneumatic Israel Ltd.  
Ha'atzma'ut Road 48  
56100 Yehud  
P +972 3 632-2266  
F +972 3 632- 2277  
info\_il@festo.com

**Italy**

Festo SpA  
Via Enrico Fermi 36/38  
20090 Assago  
P +39 02 45 78 81  
F +39 02 488 06 20  
info\_it@festo.com

**Japan**

Festo K.K.  
Hayabuchi 1-26-10  
224-0025 Yokohama  
P +81 (0)45 593 56 10 / -5611  
F +81 (0)45 593 56 78  
info\_jp@festo.com

**Jordan**

Festo AG & Co. KG  
Zahar St. 13  
11953 Amman  
P +962-6-5563646  
F +962-6-5563736  
info\_mena@festo.com

**Korea South**

Festo Korea Co., Ltd.  
Gasam Digital 1-ro  
153-803 Seoul  
P +82 1666 0202  
F +82 (0)2 864 7040  
sales\_kr@kr.festo.com

**Latvia**

Festo SIA  
Augusta Deglava 66  
1035 Riga  
P +371 67 57 78 64  
F +371 67 57 79 46  
info\_lv@festo.com

**Lithuania**

Festo, UAB  
Partizanų 63M  
50306 Kaunas  
P +370 (8)7 32 13 14  
F +370 (8)7 32 13 15  
info\_lt@festo.com



## Malaysia

Festo Sdn. Berhad  
Jalan Teknologi 14A  
47810 Kota Damansara  
P +60 (0)3 6144 1122  
F +60 (0)3 6141 6122  
info\_my@festo.com

## Mexico

Festo Pneumatic, S.A.  
Av. Ceylán 3  
54020 Tlalnepantla  
P +52 01 800 337 8669  
F +52 01 800 337 8639  
festo.mexico@mx.festo.com

## Netherlands

Festo B.V.  
Schieweg 62  
2627 AN Delft  
P +31 (0)15 251 88 99  
F +31 (0)15 251 88 67  
sales@festo.nl

## New Zealand

Festo Ltd.  
Fisher Crescent 20  
1062 Auckland  
P +64 (0)9 574 10 94  
F +64 (0)9 574 10 99  
info\_nz@festo.com

## Nigeria

Festo Automation Ltd.  
Motorways Centre  
Lagos  
P +234 (0)1 794 78 20  
F +234 (0)1 270 87 55  
sengpiel@ng-festo.com

## Norway

Festo AS  
Ole Deviks vei 2  
666 Oslo  
P +47 22 72 8950  
F +47 22 72 8951  
info\_no@festo.com

## Peru

Festo S.R.L.  
Av. Elmer Faucett 3350  
1 Lima  
P +51 (1) 219 69 60  
F +51 (1) 219 69 71  
festo.peru@pe.festo.com

## Philippines

Festo Inc.  
West Service Road KM 18  
1700 Paranaque City  
P +63 (2) 77 66 888  
F +63 (2) 82 34 220/21  
info\_ph@festo.com

## Poland

Festo Sp. z o.o.  
ul. Mszczonowska 7  
5090 Raszyn  
P +48 (0)22 711 41 00  
F +48 (0)22 711 41 02  
info\_pl@festo.com

## Portugal

Festo – Automação, Unipessoal,  
Lda.  
Rua Manuel Pinto De Azevedo 567  
P-4109601 Porto  
P +351 22 615 6150  
F +351 22 615 6189  
info.pt@festo.com

## Romania

Festo S.R.L.  
St. Constantin 17  
10217 Bucharest  
P +40(0)21 403 95 00  
F +40 (0)21 310 24 09  
info\_ro@festo.com

## Russia

OOO Festo-RF  
Michurinskiy prosp. 49  
119607 Moscow  
P +7 495 737 34 00  
F +7 495 737 34 01  
info\_ru@festo.com

## Singapore

Festo Pte. Ltd.  
Kian Teck Way 6  
628754 Singapore  
P +65 62 64 01 52  
F +65 62 61 10 26  
info@sg.festo.comxxxx

## Slovakia

Festo spol. s r.o.  
Gavlovicová ul. 1  
83103 Bratislava  
P +421 (0)2 49 10 49 10  
F +421 (0)2 49 10 49 11  
info\_sk@festo.com

## Slovenia

Festo d.o.o.  
Blatnica 8  
1236 Ljubljana  
P +386 1 530 2100  
F +386 1 530 2125  
info\_si@festo.com

## South Africa

Festo (Pty) Ltd.  
Electron Avenue, Isando 22-26  
1600 Johannesburg  
P +27 11 971-5500  
F +27 11 974-2157  
sales.interaction@za.festo.com

## Spain

Festo Pneumatic, S.A.U.  
Avenida Granvia 159  
8908 Barcelona  
P +34 901243660  
F +34 902243660  
info\_es@festo.com

## Sweden

Festo AB  
Stillmansgatan 1  
200 21 Malmö  
P +46 (0)40 38 38 00  
F +46 (0)40 38 3810  
order\_se@festo.com

## Switzerland

Festo AG  
Gass 10  
5242 Lupfig  
P +41 44 744 5544  
F +41 44 744 5500  
info.ch@festo.com

## Taiwan

Festo Co., Ltd.  
Kung 8th Road 9  
24450 New Taipei City  
P +886 (0)2 26 01-92 81  
F +886 (0)2 26 01 92 86-7  
info\_tw@tw.festo.com

## Thailand

Festo Ltd.  
1250 Bangna - Trad Road (Soi 34)  
1250  
10260 Bangkok  
P +66 2746-8700  
F +66 2746-8370  
info\_th@festo.com

## Turkey

Festo San. ve Tic. A.S.  
Aydinli Mah. TEM Yan Yol Cad. 16  
34953 Istanbul  
P +90 (0)216 585 00 85  
F +90 (0)216 585 00 50  
info\_tr@festo.com

## Ukraine

DP Festo  
ul. Borissoglebskaya 11  
4070 Kiev  
P +380 (0)44 233 6451  
F +380 (0)44 463 7096  
orders\_ua@festo.com

## United Kingdom

Festo Limited  
Caswell Road .  
NN4 7PY Northampton  
P +44 (0)1604 / 66 70 00  
F +44 (0)1604 / 66 70 01  
info\_gb@festo.com

## United States

Festo Corporation  
Moreland Road 395  
11788 Hauppauge  
P +1 800 993 3786  
F +1 800 963 3786  
customer.service@us.festo.com

## Venezuela

Festo C.A.  
Av. 23 esquina con calle 71 22-62  
Maracaibo  
P +58 (261) 759 11 20 / 41 20  
F +58 (261) 759 1417  
festo@ve.festo.com

## Vietnam

Festo Co Ltd  
Van Dai Dong Street 1515 – 1516  
Ho Chi Minh City  
P +84 (8) 62 81 4453 4454  
F +84 (8) 62 81 4442  
info\_vn@festo.com



The limit values specified in the technical data and any specific safety instructions must be adhered to by the user in order to ensure correct functioning.

When using pneumatic components, ensure that they are operated using correctly prepared compressed air without aggressive media and that they comply with environmental specifications (e. g. climate).

When Festo products are used in safety-oriented applications, all national and local laws and regulations, for example the Machinery Directive, together with the relevant references to standards, trade association rules and the applicable international regulations must be observed and complied with.

Unauthorised conversions or modifications to products and systems from Festo constitute a safety risk and are thus not permitted. Festo does not accept any liability for the resulting damages.

You should contact Festo if one of the following applies to your application:

- The ambient conditions and conditions of use or the operating medium differ from the specified technical data.
- The product is to perform a safety function.
- A risk or safety analysis is required.
- You are unsure about the product's suitability for the planned application.
- You are unsure about the product's suitability for use in safety-oriented applications.

All technical data is correct at the time of going to print.

All texts, representations, illustrations and drawings included in this catalogue are the intellectual property of Festo AG & Co. KG, and are protected by copyright law. No part of this publication may be reproduced or transmitted in any form or by any means, electronic, mechanical, photocopying or otherwise, without the prior written permission of Festo AG & Co. KG. All technical data is subject to change according to technical advances.



Product overview 2017

Version 2017/01

All technical data is correct at the time of going to print.

All texts, representations, illustrations and drawings included in this catalogue are the intellectual property of Festo AG & Co. KG, and are protected by copyright law. No part of this publication may be reproduced or transmitted in any form or by any means, electronic, mechanical, photocopying or otherwise, without the prior written permission of Festo AG & Co. KG.

All technical data are subject to change according to technical updates.

Festo AG & Co. KG  
Postfach 73726 Esslingen  
Ruiter Strasse 82  
73734 Esslingen Germany

.com.ar  
.at  
.com.au  
.be  
.bg  
.com.br  
.by  
.ca  
.ch  
.cl  
.cn  
.co  
.cz  
.de  
.dk  
.ee  
.es  
.fi  
.fr  
.gr  
.hk  
.hr  
.hu  
.co.id  
.ie  
.co.il  
.in  
.ir  
.it  
.jp  
.kr  
.lt  
.lv  
.mx

Festo worldwide  
[www.festo.com](http://www.festo.com)

.com.my  
.nl  
.no  
.co.nz  
.pe  
.ph  
.pl  
.pt  
.ro  
.ru  
.se  
.sg  
.si  
.sk  
.co.th  
.com.tr  
.tw  
.ua  
.co.uk  
.us  
.co.ve  
.vn  
.co.za